

GENERAL MATHEMATICS

10

Published by:



ALI BROTHERAN

G/1-2, Punjab Plaza, Urdu Bazar, Lahore.

Phone: 042-37242233, Fax: 042-37361207

Website: www.alibrotheran.com, Email: Info@alibrotheran.com

All rights reserved with Ali Brotheran (Publishers) Lahore.
 Approved by Punjab Curriculum Authority (Punjab) Lahore,
 According to the National Curriculum 2006 under the
 National Textbook and Learning Materials Policy 2007.
 N.O.C No: PCA-12/19, Dated 27 November 2012

Contents

UNITS	TOPICS	PAGE No.
1	Algebraic Formulas and Applications	1
2	Factorization	35
3	Algebraic Manipulation	57
4	Linear Equations and Inequalities	85
5	Quadratic Equations	107
6	Matrices and Determinants	127
7	Fundamental of Geometry	175
8	Practical Geometry	221
9	Areas and Volumes	247
10	Introduction of Coordinate Geometry	275
	Answers	289
	Glossary	301
	Symbols	306
	Index	307

Members Review Committee

Dr. Tariq Mahmood,
 DEA, Curriculum & Textbook Wing,
 Ministry of CAD, Islamabad

Prof. Dr. M. Aslam,
 Mathematics Department,
 Quaid-i-Azam University, Islamabad

Prof. Dr. Shahid Mubeen,
 Mathematics Department,
 Sargodha University, Sargodha

Mr. Munawar Din Awan,
 AEA (R), Curriculum Wing,
 Federal Ministry of Education (Defunct), Islamabad

Prof. Dr. M. Aslam Malik,
 Mathematics Department,
 Punjab University, Quaid-i-Azam Campus, Lahore

Dr. Bushra,
 Senior Headmistress,
 Govt. Muslim Model Girls High School, Gujranawala

Mr. Irfan Hussain,
 Government High School, Kot Ranjeet, Sheikhpura

Mr. Faheem Hussain,
 Senior Subject Specialist,
 Punjab Textbook Board, Lahore

Mr. Afzaal Hussain,
 Desk Officer,
 Punjab Curriculum Authority, Wahdat Colony, Lahore
 Deputy Director
 (Curriculum Wing), Punjab Textbook Board, Lahore

Authors : Dr. Muhammad Ozair Ahmad,
 (Ph.D)

Maqsood Raza Ahmed
 (M.Sc, M.Phil)

Editor : Javaid Iqbal
 (M.Sc)

Published by : Ali Brotheran, Lahore.

Coordinator : Mahboob Ali Asim

Printed at : Nawaz Printing Press,
 Lahore.

Designing : Kashif Latif

Date of printing	Edition	Impression	Copies	Price
March 2020	4th	1st	5,000	193.00

UNIT

1

ALGEBRAIC FORMULAS AND APPLICATIONS

- ▶ Algebraic Expressions
- ▶ Algebraic Formulas
- ▶ Surds and their Applications
- ▶ Rationalization

After completion of this unit, the students will be able to:

- ▶ know that a rational expression behaves like a rational number.
- ▶ define a rational expression as the quotient $\frac{p(x)}{q(x)}$ of two polynomials $p(x)$ and $q(x)$ where $q(x)$ is not the zero polynomial.
- ▶ examine whether a given algebraic expression is a
 - Polynomial or not.
 - Rational expression or not.
- ▶ define $\frac{p(x)}{q(x)}$ as a rational expression in its lowest terms if $p(x)$ and $q(x)$ are polynomials with integral coefficients and having no common factor.
- ▶ examine whether a given rational algebraic expression is in lowest form or not.
- ▶ reduce a given rational expression to its lowest terms.
- ▶ find the sum, difference and product of rational expressions.
- ▶ divide a rational expression with another and express the result in its lowest terms.
- ▶ find value of algebraic expression at some particular real number.
- ▶ know the formulas
$$(a+b)^2 + (a-b)^2 = 2(a^2 + b^2) \quad (a+b)^2 - (a-b)^2 = 4ab$$
 - Find the value of $a^2 + b^2$ and of ab when the values of $a+b$ and $a-b$ are known.
- ▶ know the formula
$$(a+b+c)^2 = a^2 + b^2 + c^2 + 2ab + 2bc + 2ca.$$
 - Find the value of $a^2 + b^2 + c^2$ when the values of $a+b+c$ and $ab+bc+ca$ are given.
 - Find the value of $a+b+c$ when the values of $a^2 + b^2 + c^2$ and $ab+bc+ca$ are given.
 - Find the value of $ab+bc+ca$ when the values of $a^2 + b^2 + c^2$ and $a+b+c$ are given.
- ▶ know the formulas
$$(a \pm b)^3 = a^3 \pm 3ab(a \pm b) \pm b^3, \quad a^3 \pm b^3 = (a \pm b)(a^2 \mp ab + b^2).$$
 - Find the value of $a^3 \pm b^3$ when the values of $a \pm b$ and ab are given.
 - Find the continued product of $(x+y)(x-y)(x^2 + xy + y^2)(x^2 - xy + y^2)$.
- ▶ recognize the surds and their applications.
- ▶ explain the surds of second order. Use basic operations on surds of second order to rationalize the denominators and evaluate it.
- ▶ explain rationalization (with precise meaning) of real numbers of the types $\frac{1}{a+b\sqrt{x}}$, $\frac{1}{\sqrt{x}+\sqrt{y}}$ and their combinations where x and y are natural numbers and a, b are integers.

1.1 ALGEBRAIC EXPRESSIONS

Algebra is an extension of arithmetic. In algebra, we use alphabets such as a, b, c to stand for constants and x, y, z to stand for any numerical value we choose.

An algebraic expression involves numbers and letters together with operational signs such as $+, -, \times, \div$. The signs $+$ and $-$ separate an algebraic expression into terms.

Example:

$ax + by$	consists of 2 terms
$3x - 2y$	consists of 2 terms
$9x^2 - 7xy + 7y^2$	consists of 3 terms
$5xy$	consists of 1 term

The numbers $a, b, 3, 2, 9, 7, 5$ in these expressions are called coefficients, while the letters x, y are known as variables.

An algebraic expression is of three types.

(i) *Polynomial*

(ii) *Rational*

(iii) *Irrational*

A polynomial of degree n in variable ' x ' is defined as:

$$P(x) = a_n x^n + a_{n-1} x^{n-1} + a_{n-2} x^{n-2} + \dots + a_3 x^3 + a_2 x^2 + a_1 x + a_0,$$

where ' n ' is a non-negative integer and $a_n, a_{n-1}, a_{n-2}, \dots, a_3, a_2, a_1, a_0$ are real numbers, where as $a_n \neq 0$.

As the highest power of the variable ' x ' in this polynomial is ' n ', therefore this polynomial is of degree ' n '.

1.1.1 Rational Expression

We know that a number of the form $\frac{p}{q}, q \neq 0, p, q \in Z$, is called a rational number.

An expression which can be written in the form $\frac{P(x)}{Q(x)}$, $Q(x) \neq 0$, where $P(x)$ and $Q(x)$ are polynomials in 'x' is called a rational expression.

For example:

$$(i) \frac{x^2 + 1}{x^3 + x^2 + 3} \quad (ii) \frac{x^3 + 8}{x + 1} \quad (iii) \frac{2x^2 + 3x + 3}{x^2 + x + 2} \quad (iv) \frac{x + 1}{x^2 + 2x + 3}$$

are all rational expressions. The rational expressions can also be added, subtracted, multiplied and divided like rational numbers.

Rational expressions are of two types.

(i) *Proper Rational Expression*

(ii) *Improper Rational Expression*

Proper Rational Expression:-

A rational expression $\frac{P(x)}{Q(x)}$, $Q(x) \neq 0$, in which the degree of $P(x)$ is less than the degree of $Q(x)$ is called a proper rational expression.

For example:

$$\frac{x + 1}{x^2 + 3x + 7}, \frac{3x^3 + 4x^2 + 5}{2x^4 + 1}$$

Improper Rational Expression

A rational expression $\frac{P(x)}{Q(x)}$, $Q(x) \neq 0$, in which the degree of $P(x)$ is either equal or greater than the degree of $Q(x)$ is called an improper rational expression. For example:

$$\frac{x^2 + 2x + 4}{x + 1}, \frac{x^2 + 4x + 9}{x^2 + 1}, \frac{x^3 + 1}{x^2 - x + 4}, \frac{x + 5}{x - 1}$$

1.1.3 Examine a Given Algebraic Expression

Let us consider the following:

$$(i) 2x^2 + 3x + 9 \quad (ii) x + 5 \quad (iii) \sqrt{x} + \frac{1}{\sqrt{x}} + 1 \quad (iv) \frac{-4}{x^3}$$

(i) and (ii) are Polynomials, but (iii) and (iv) are not polynomials, because in (iii) and (iv) the powers of the variables are negative and rational numbers.

Consider the following as well:

$$(i) \frac{x+1}{x^3+x^2+3} \quad (ii) \frac{x^3+1}{x-1} \quad (iii) \sqrt[3]{x} + \frac{1}{\sqrt[3]{x}} + 1$$
$$(iv) 2\sqrt{y} + \frac{3}{\sqrt{x}} + 1 \quad (v) \frac{\sqrt{y}+3}{x^{2/3}}$$

(i) and (ii) are rational expressions, but (iii), (iv) and (v) are not rational expressions, because the powers of the variables are not integers.

1.1.4 Rational Expression in its Lowest Terms

If A, B and C are polynomials where $B, C \neq 0$, then $\frac{AC}{BC} = \frac{A}{B}$;

(which is the fundamental principle of fractions)

This is used to reduce a rational fraction to its lowest terms.

A rational expression is in its lowest terms, when the numerator and denominator have no common factors other than 1 and -1.

To examine whether the given rational expression is in its lowest terms or not, let us consider the following example.

EXAMPLE Find the lowest term of $\frac{8x^3y^2}{12xy^5}$.

SOLUTION:

$$\begin{aligned}\frac{8x^3y^2}{12xy^5} &= \frac{2x^2 \cdot 4xy^2}{3y^3 \cdot 4xy^2} \\ &= \frac{2x^2}{3y^3}\end{aligned}$$

Thus to examine a rational expression in lowest terms, we first write the numerator and denominator in factored form and then use the fundamental principle of fractions to obtain,

$$\begin{aligned}\frac{b^2 - a^2}{b^3 - a^3} &= \frac{(b-a)(b+a)}{(b-a)(b^2 + ab + a^2)} \\ &= \frac{b+a}{b^2 + ab + a^2}\end{aligned}$$

1.1.5 Reduce a Rational Expression to its Lowest Terms

EXAMPLE Reduce to lowest terms:

(i) $\frac{32x^5y^7}{-4x^2y^9}$ (ii) $\frac{2-x}{3x^2-5x-2}$

SOLUTION:

$$\begin{aligned}\text{(i)} \quad \frac{32x^5y^7}{-4x^2y^9} &= -\frac{8x^3 \cdot 4x^2y^7}{y^2 \cdot 4x^2y^7} \\ &= -\frac{8x^3}{y^2} \\ \text{(ii)} \quad \frac{2-x}{3x^2-5x-2} &= \frac{2-x}{3x^2-6x+x-2} \\ &= \frac{2-x}{3x(x-2)+1(x-2)} \\ &= \frac{2-x}{(3x+1)(x-2)} \\ &= \frac{(-1)(x-2)}{(3x+1)(x-2)} \\ &= \frac{-1}{3x+1}\end{aligned}$$

1.1.6 Sum, Difference and Product of Rational Expressions

We find the sum, difference and product of rational expression with the help of following examples:

EXAMPLE-1

Solve:

$$(i) \frac{x+1}{x^2-3x+2} + \frac{x+2}{x^2-4x+3}$$

$$(ii) \frac{x+2}{x^3+1} + \frac{x}{x^2-1}$$

SOLUTION: (i) $\frac{x+1}{x^2-3x+2} + \frac{x+2}{x^2-4x+3}$

$$= \frac{x+1}{x^2-2x-x+2} + \frac{x+2}{x^2-3x-x+3}$$

$$= \frac{x+1}{x(x-2)-1(x-2)} + \frac{x+2}{x(x-3)-1(x-3)}$$

$$= \frac{x+1}{(x-2)(x-1)} + \frac{x+2}{(x-3)(x-1)}$$

$$= \frac{(x+1)(x-3) + (x+2)(x-2)}{(x-1)(x-2)(x-3)}$$

$$= \frac{x^2-3x+x-3+x^2-2x+2x-4}{(x^2-2x-x+2)(x-3)}$$

$$= \frac{2x^2-2x-7}{(x^2-3x+2)(x-3)}$$

$$= \frac{2x^2-2x-7}{x^3-6x^2+11x-6}$$

$$\begin{aligned}
 \text{(ii)} \quad & \frac{x+2}{x^3+1} + \frac{x}{x^2-1} \\
 &= \frac{x+2}{(x+1)(x^2-x+1)} + \frac{x}{(x-1)(x+1)} \\
 &= \frac{(x+2)(x-1) + x(x^2-x+1)}{(x+1)(x-1)(x^2-x+1)} \\
 &= \frac{x^2+2x-x-2+x^3-x^2+x}{(x^2-1)(x^2-x+1)} \\
 &= \frac{x^3+2x-2}{x^4-x^3+x^2-x^2+x-1} \\
 &= \frac{x^3+2x-2}{x^4-x^3+x-1}
 \end{aligned}$$

EXAMPLE-2

Solve:

$$\text{(i)} \quad \frac{x+3}{x^2-4} - \frac{x-1}{x+2}$$

$$\text{(ii)} \quad \frac{x+5}{x^2-6x} - \frac{x}{x-6}$$

SOLUTION: (i) $\frac{x+3}{x^2-4} - \frac{x-1}{x+2}$

$$= \frac{x+3}{(x-2)(x+2)} - \frac{x-1}{x+2}$$

$$= \frac{(x+3)(1) - (x-1)(x-2)}{(x-2)(x+2)}$$

$$= \frac{x+3-(x^2-2x-x+2)}{x^2-4}$$

$$= \frac{x+3-x^2+3x-2}{x^2-4}$$

$$= \frac{4x-x^2+1}{x^2-4}$$

$$= \frac{1+4x-x^2}{x^2-4}$$

$$(ii) \quad \frac{x+5}{x^2-6x} - \frac{x}{x-6}$$

$$= \frac{x+5}{x(x-6)} - \frac{x}{x-6}$$

$$= \frac{x+5-x \cdot x}{x(x-6)}$$

$$= \frac{x+5-x^2}{x^2-6x}$$

$$= \frac{5+x-x^2}{x^2-6x}$$

EXAMPLE-3

Simplify:

$$(i) \quad \frac{x^2+x}{x^2-x} \times \frac{x-1}{x^3+1}$$

$$(ii) \quad \frac{2x^2}{2x-1} \times \frac{2x-1}{6x+1}$$

SOLUTION: (i) $\frac{x^2+x}{x^2-x} \times \frac{x-1}{x^3+1}$

$$= \frac{x(x+1)}{x(x-1)} \times \frac{x-1}{(x+1)(x^2-x+1)}$$

$$= \frac{x(x+1)(x-1)}{x(x-1)(x+1)(x^2-x+1)}$$

$$= \frac{1}{x^2-x+1}$$

$$(ii) \frac{2x^2}{2x-1} \times \frac{2x-1}{6x+1}$$

$$= \frac{2x^2(2x-1)}{(2x-1)(6x+1)}$$

$$= \frac{2x^2}{6x+1}$$

1.1.7 Division of a Rational Expression

The rule of division of rational expression is first factorize the expression and then cancel the same expressions in numerator and denominator.

EXAMPLE

Simplify:

$$(i) \frac{x^2-2x}{x+1} \div \frac{x^2-4}{x^2+2x+1}$$

$$(ii) \frac{3x-1}{1+x} \div \frac{1-3x}{x^2+2x+1}$$

SOLUTION: (i) $\frac{x^2-2x}{x+1} \div \frac{x^2-4}{x^2+2x+1}$

$$= \frac{x(x-2)}{x+1} \div \frac{(x-2)(x+2)}{(x+1)^2}$$

$$\begin{aligned}
 & x+2 \\
 \text{(ii)} \quad & \frac{3x-1}{1+x} \div \frac{1-3x}{x^2+2x+1} \\
 & = \frac{3x-1}{1+x} \div \frac{1-3x}{(x+1)^2} \\
 & = \frac{3x-1}{1+x} \times \frac{(x+1)(x+1)}{1-3x} \\
 & = \frac{(3x-1)(x+1)}{(1-3x)} \\
 & = \frac{(3x-1)(x+1)}{-(3x-1)} \\
 & = -(x+1)
 \end{aligned}$$

1.1.8 Value of an Algebraic Expression

If we put a real number against a variable "x" in a polynomial $P(x)$, we get a real number. This real number is called value of $P(x)$. For $x = a, a \in R$, $P(x)$ will have the value $P(a)$.

For example:

If $P(x) = 4x^3 + 3x^2 + 5x + 1$, then find $P(x)$, for (i) $x = 1$, (ii) $x = 2$.

$$P(x) = 4x^3 + 3x^2 + 5x + 1$$

$$\begin{aligned}
 \text{(i)} \quad P(1) &= 4(1)^3 + 3(1)^2 + 5(1) + 1 \\
 &= 4 + 3 + 5 + 1 \\
 &= 13
 \end{aligned}$$

Thus $P(1) = 13$ and

$$\begin{aligned}
 \text{(ii)} \quad P(2) &= 4(2)^3 + 3(2)^2 + 5(2) + 1 \\
 &= 32 + 12 + 10 + 1 = 55
 \end{aligned}$$

Thus $P(2) = 55$

EXAMPLE-1

If $P(x) = 4x^4 + 3x^2 - 5x + 1$, then find $P(-1)$

SOLUTION: Given: $P(x) = 4x^4 + 3x^2 - 5x + 1$

$$\begin{aligned}P(-1) &= 4(-1)^4 + 3(-1)^2 - 5(-1) + 1 \\ &= 4 + 3 + 5 + 1 \\ &= 13\end{aligned}$$

EXAMPLE-2

If $P(x) = \frac{x^2 - 5x + 6}{x^3 + 8}$, then find $P(1)$

SOLUTION: $P(x) = \frac{x^2 - 5x + 6}{x^3 + 8}$

$$\begin{aligned}P(1) &= \frac{1^2 - 5(1) + 6}{1^3 + 8} = \frac{1 - 5 + 6}{1 + 8} \\ &= \frac{2}{9}\end{aligned}$$

EXERCISE - 1.1

Solve:

- 1- If $P(x) = x^4 + 3x^2 - 5x + 9$, then find $P(x)$, for $x = 0, x = 1$.
- 2- If $P(x) = 2x^3 + 2x^2 + x - 1$, then find $P(-2)$.
- 3- If $P(y) = 3y^2 + \frac{y}{4} + 9$, then find $P(0)$.
- 4- If $P(x) = 9x^3 - 2x^2 + 3x + 1$, then find $P(1)$ and $P(2)$.
- 5- If $P(x) = \frac{x^2 - 5x + 6}{x + 1}$, then find $P(1)$ and $P(2)$.
- 6- If $P(r) = 2\pi r$, then find $P(r)$, for $r = 3$ and $\pi = \frac{22}{7}$.
- 7- If $P(r) = 4\pi r^2$, then find $P(r)$, for $r = 8$ and $\pi = \frac{22}{7}$.
- 8- If $P(y) = y^4 + \frac{3y^3}{2} - y^2 + 1$, then find $P(y)$, for $y = 2$ and $y = -2$.

Reduce the given rational expressions to lowest terms.

$$9. \frac{8x^2y^2}{12x^4y}$$

$$10. \frac{25a^3b^2}{14a^2b^4}$$

$$11. \frac{16a^6b^7}{12a^3b^5 + 20a^5b^4}$$

$$12. \frac{18m^5x^3}{27m^4x^8 - 36m^6x^6}$$

$$13. \frac{5c-5d}{c^2-d^2}$$

$$14. \frac{x^2-y^2}{3y-3x}$$

Simplify:

$$15. \frac{x}{x-y} + \frac{x^2}{x^2+y^2}$$

$$16. \frac{x^2+2x}{x^2+x-2} + \frac{3x}{x+1}$$

$$17. \frac{x+2}{x^2+3x+2} - \frac{x-5}{x^2-x-6}$$

$$18. \frac{8x^2+18y^2}{4x^2-9y^2} - \frac{2x+3y}{2x-3y}$$

$$19. \frac{x}{x^2+xy} - \frac{y}{x^2-y^2}$$

$$20. \frac{x+y}{xy+y^2} - \frac{x}{x^2-xy}$$

$$21. \frac{(x+1)^2}{x^2-1} \cdot \frac{x^2+1}{x^2+1}$$

$$22. \frac{5x}{x-9} + \frac{x^2-2x+1}{x^2-12x+27} - \frac{6x}{x-3}$$

$$23. \frac{x^2-4x+4}{x^2-4} \div \frac{x}{x-2}$$

$$24. \frac{x^2-36}{x^2-1} \div \frac{x-6}{1-x}$$

$$25. \frac{x^2-5x}{x-1} \div \frac{x^2-25}{x^2+x+20}$$

$$26. \frac{2x^2-5x-12}{4x^2+4x-3} \div \frac{2x^2-7x-4}{6x^2+5x-4}$$

$$27. \frac{x(2x-1)^2}{2x^2-1} \div \frac{4x^2-1}{4x^2+4x+1}$$

$$28. \frac{x^2+x}{x^2-1} \times \frac{x+1}{x^3+1}$$

$$29. \frac{x^2-9}{x^2-6x+9} \times \frac{x}{3x+9}$$

$$30. \frac{x+5}{x^2+6x} \times \frac{x^3+6x^2}{x+5}$$

$$31. \frac{x^2-2x+1}{x^2-1} \times \frac{x+1}{x-1}$$

$$32. \frac{x^2+4x+3}{x+3} \times \frac{x^2-2x+1}{x^2-1}$$

1.2. FORMULAE:

A formula expresses a rule in algebraic terms, its plural is formulae.

1.2.1 Formula 1

$$(a+b)^2 + (a-b)^2 = 2(a^2 + b^2)$$

Proof: $L.H.S = (a+b)^2 + (a-b)^2$

$$= a^2 + 2ab + b^2 + a^2 - 2ab + b^2$$

$$= 2a^2 + 2b^2$$

$$= 2(a^2 + b^2)$$

$$= R.H.S$$

Formula 2

$$(a+b)^2 - (a-b)^2 = 4ab$$

Proof: $L.H.S = (a+b)^2 - (a-b)^2$

$$= (a^2 + 2ab + b^2) - (a^2 - 2ab + b^2)$$

$$= a^2 + 2ab + b^2 - a^2 + 2ab - b^2$$

$$= 4ab$$

$$= R.H.S$$

EXAMPLE-1

Find the value of $a^2 + b^2$ when $a + b = 8$ and $ab = 12$

SOLUTION: Given $a + b = 8$

$$(a+b)^2 = 8^2$$

Squaring both the sides

$$a^2 + 2ab + b^2 = 64$$

$$a^2 + b^2 = 64 - 2ab$$

$$= 64 - 2(12) \quad \because ab = 12$$

$$= 64 - 24$$

$$a^2 + b^2 = 40$$

The symbol " \therefore " stands for "because"

EXAMPLE-2

Find the value of ab when $a + b = 9$ and $a - b = 3$

SOLUTION: We have

$$(a + b)^2 - (a - b)^2 = 4ab$$

$$(9)^2 - (3)^2 = 4ab$$

$$81 - 9 = 4ab$$

$$4ab = 72$$

$$ab = \frac{72}{4}$$

$$ab = 18$$

1.2.2 Formula 3

$$(a + b + c)^2 = a^2 + b^2 + c^2 + 2ab + 2bc + 2ca$$

Proof: Put $p = a + b$

$$\text{L.H.S} = (a + b + c)^2 = (p + c)^2$$

$$= p^2 + 2pc + c^2$$

$$= (a + b)^2 + 2(a + b)c + c^2 \quad (\text{where } p = a + b)$$

$$= a^2 + 2ab + b^2 + 2ac + 2bc + c^2$$

$$= a^2 + b^2 + c^2 + 2ab + 2bc + 2ca$$

$$= \text{R.H.S}$$

EXAMPLE-3

Find the value of $a^2 + b^2 + c^2$ when $a + b + c = 12$ and

$$ab + bc + ca = 8$$

SOLUTION: We have

$$(a + b + c)^2 = a^2 + b^2 + c^2 + 2ab + 2bc + 2ca$$

$$= a^2 + b^2 + c^2 + 2(ab + bc + ca)$$

$$(12)^2 = a^2 + b^2 + c^2 + 2(8)$$

$$144 = a^2 + b^2 + c^2 + 16$$

$$a^2 + b^2 + c^2 = 128$$

EXAMPLE-4

Find the value of $a+b+c$ when $a^2+b^2+c^2 = 100$ and $ab+bc+ca = 22$

SOLUTION: We have

$$\begin{aligned}(a+b+c)^2 &= a^2+b^2+c^2+2ab+2bc+2ca \\ &= (a^2+b^2+c^2)+2(ab+bc+ca) \\ &= 100+2(22)\end{aligned}$$

$$= 100+44$$

$$(a+b+c)^2 = 144$$

$$(a+b+c)^2 = (12)^2$$

$$a+b+c = \pm 12$$

RESULTS

$$(i) \quad x^2 = a^2$$

$$x = \pm a$$

$$(ii) \quad x^2 = a$$

$$x = \pm \sqrt{a}$$

EXAMPLE-5

Find the value of $ab+bc+ca$ when $a^2+b^2+c^2 = 36$ and $a+b+c = 8$

SOLUTION: We have

$$(a+b+c)^2 = a^2+b^2+c^2+2ab+2bc+2ca$$

$$8^2 = 36+2(ab+bc+ca)$$

$$64-36 = 2(ab+bc+ca)$$

$$2(ab+bc+ca) = 28$$

$$ab+bc+ca = \frac{28}{2} \quad (\text{Dividing by 2 on both sides})$$

$$ab+bc+ca = 14$$

1.2.3 Formula 4

$$(a+b)^3 = a^3 + 3ab(a+b) + b^3$$

Proof: $L.H.S = (a+b)^3$

$$= (a+b)^2 (a+b)$$

$$= (a^2 + 2ab + b^2) (a+b)$$

$$= a^3 + a^2b + 2a^2b + 2ab^2 + b^2a + b^3$$

$$= a^3 + 3a^2b + 3ab^2 + b^3$$

$$= a^3 + 3ab(a+b) + b^3$$

$$= R.H.S$$

Formula 5

$$(a-b)^3 = a^3 - 3ab(a-b) - b^3$$

Proof: $L.H.S = (a-b)^3$

$$= (a-b)^2 (a-b)$$

$$= (a^2 - 2ab + b^2) (a-b)$$

$$= a^3 - a^2b - 2a^2b + 2ab^2 + b^2a - b^3$$

$$= a^3 - 3a^2b + 3ab^2 - b^3 \quad (\because ab^2 = b^2a)$$

$$= a^3 - 3ab(a-b) - b^3$$

$$= R.H.S$$

Formula 6

$$a^3 + b^3 = (a + b)(a^2 - ab + b^2)$$

Proof: $R.H.S = (a + b)(a^2 - ab + b^2)$

$$= a^3 - a^2b + ab^2 + a^2b - ab^2 + b^3$$

$$= a^3 + b^3$$

$$= L.H.S$$

Formula 7

$$a^3 - b^3 = (a - b)(a^2 + ab + b^2)$$

Proof: $R.H.S = (a - b)(a^2 + ab + b^2)$

$$= a^3 + a^2b + ab^2 - a^2b - ab^2 - b^3$$

$$= a^3 - b^3$$

$$= L.H.S$$

EXAMPLE-6

Find the value of $x^3 + y^3$ when $xy = 8$ and $x + y = 5$

SOLUTION: $x + y = 5$ (Given)

$$(x + y)^3 = (5)^3 \quad (\text{Taking cube of both the sides})$$

$$x^3 + y^3 + 3xy(x + y) = 125$$

$$x^3 + y^3 + 3(8)(5) = 125 \quad (\text{Putting } x + y = 5 \text{ and } xy = 8)$$

$$x^3 + y^3 + 120 = 125$$

$$x^3 + y^3 = 125 - 120$$

$$\therefore x^3 + y^3 = 5$$

EXAMPLE-7

Find the value of $a^3 - b^3$ when the values of $a - b = 6$ and $ab = 7$

SOLUTION: $a - b = 6$ (Given)

$$(a - b)^3 = (6)^3 \quad (\text{Taking cube of both the sides})$$

$$a^3 - b^3 - 3ab(a - b) = 216$$

$$a^3 - b^3 - 3(7)(6) = 216$$

$$a^3 - b^3 - 126 = 216$$

$$a^3 - b^3 = 216 + 126$$

$$a^3 - b^3 = 342$$

EXAMPLE-8

Resolve into factors $x^3 p^2 - 8y^3 p^2 - 4x^3 q^2 + 32y^3 q^2$

SOLUTION: $x^3 p^2 - 8y^3 p^2 - 4x^3 q^2 + 32y^3 q^2$ (Rearranging the terms)

$$= p^2(x^3 - 8y^3) - 4q^2(x^3 - 8y^3)$$

$$= (p^2 - 4q^2)(x^3 - 8y^3)$$

$$= [(p)^2 - (2q)^2] [(x)^3 - (2y)^3]$$

$$= (p - 2q)(p + 2q)(x - 2y)(x^2 + 2xy + 4y^2)$$

EXAMPLE-9

Factorize $64x^6 - 729y^6$

SOLUTION: $64x^6 - 729y^6 = 2^6 x^6 - 3^6 y^6$

$$= (2x)^6 - (3y)^6$$

$$= [(2x)^3]^2 - [(3y)^3]^2$$

$$= [(2x)^3 - (3y)^3] [(2x)^3 + (3y)^3]$$

$$= (2x - 3y)[4x^2 + 6xy + 9y^2](2x + 3y)[4x^2 - 6xy + 9y^2]$$

The symbol “ \therefore ” stands for “therefore”

EXAMPLE-10

Resolve into factors. $(x+y)^3 + 64$

SOLUTION: $(x+y)^3 + 64$

$$= (x+y)^3 + (4)^3$$

$$= (x+y+4)[(x+y)^2 - (x+y)4 + (4)^2]$$

$$= (x+y+4)[x^2 + y^2 + 2xy - 4x - 4y + 16]$$

EXAMPLE-11

Find the continued product for $x^6 - y^6$.

SOLUTION: $x^6 - y^6$

$$= (x^3)^2 - (y^3)^2$$

$$= (x^3 + y^3)(x^3 - y^3)$$

$$= (x+y)(x^2 - xy + y^2)(x-y)(x^2 + xy + y^2)$$

$$= (x+y)(x-y)(x^2 - xy + y^2)(x^2 + xy + y^2)$$

EXERCISE - 1.2

Solve the Following Questions Using Formulas.

- $(x+2y)^2 + (x-2y)^2$
- $(5x+3y)^2 + (5x-3y)^2$
- $(3l+2m)^2 - (3l-2m)^2$
- $(l+m)(l-m)(l^2+m^2)(l^4+m^4)$

5. $(ab - \frac{1}{ab})^3$

6. $(2x + 3y + 2)^2$

7. $(2p + q)^3$

8. $(3p + q + r)^2$

9. $(2x + 3y)^3$

10. $(x + y)^3 - 1$

11. $(x - y)^3 + 64$

12. $8x^3 + 27y^3$

13. $x^6 - 729y^6$

14. $64a^6 - b^6$

15. Find the value of $a^3 - b^3$ when $a - b = 4$ and $ab = -5$.

16. Show that $(z + \frac{1}{z})^2 - (z - \frac{1}{z})^2 = 4$.

17. Find the value of $a^2 + b^2$ and ab when $a + b = 5$ and $a - b = 3$.

18. Find the value of $a^2 + b^2 + c^2$ if $ab + bc + ca = 11$ and $a + b + c = 6$.

19. Find the value of $x^3 + y^3$ if $xy = 10$ and $x + y = 7$.

20. Find the value of $(x - y)^2$ if $x^2 + y^2 = 86$ and $xy = -16$.

21. Find the value of $ab + bc + ca$ when the values of $a^2 + b^2 + c^2 = 81$, $a + b + c = 11$.

22. Find the value of $(a + b + c)^2$ when the values of $a^2 + b^2 + c^2 = 32$ and $ab + bc + ca = 7$.

1.3 SURDS AND THEIR APPLICATIONS

1.3.1 Surds

Rational Numbers:

A number which can be expressed in the form $\left(\frac{p}{q}\right)$, where 'p' and 'q' are integers and $q \neq 0$ is called a rational number.

e.g. $\frac{3}{4}, \frac{2}{1}, \frac{8}{7}, \frac{-2}{5}$ are all rational numbers.

Irrational Numbers:

A real number which is not a rational number, is called an irrational number. For example:

$\sqrt{2}, \sqrt{3}, \sqrt{5}, \sqrt{7}$ etc. are irrational numbers.

Clearly, an irrational number cannot be expressed in the form $\left(\frac{p}{q}\right)$, where p and q are integers and $q \neq 0$.

Real Numbers:

The set \mathbb{R} of all real numbers is the union of two disjoint subsets, namely the set Q of all rational numbers and the set Q' of all irrational numbers.

Surds of Radicals:

A surd is an irrational number that contains a radical sign.

e.g. $\sqrt{2}, 2\sqrt{3}, 4+3\sqrt{5}, 10-4\sqrt{6}, \frac{\sqrt{2}}{5}, \frac{9}{\sqrt{7}}$ are all surds.

EXAMPLE

- (i) $\sqrt{3} = 3^{\frac{1}{2}}$ is a surd of order 2, i.e. it is a quadratic surd.
- (ii) $\sqrt[3]{4} = 4^{\frac{1}{3}}$ is a surd of order 3, i.e. it is a cubic surd.
- (iii) $\sqrt[n]{a} = a^{\frac{1}{n}}$ is called a surd of radical of order 'n' and 'a' is called the radicand.

The symbol "i.e." stands for "That is"

Laws of Radicals:

As the surd can be expressed with rational exponents, the laws of indices, are therefore, applicable in surds also.

Thus for any positive integer 'n' and positive rational numbers 'a and b', we have the following laws:

Laws of Radicals	Laws of Indices
(i) $(\sqrt[n]{a})^n = a$	(i) $\left(a^{\frac{1}{n}}\right)^n = a$
(ii) $\sqrt[n]{ab} = \sqrt[n]{a} \sqrt[n]{b}$	(ii) $(ab)^{\frac{1}{n}} = a^{\frac{1}{n}} b^{\frac{1}{n}}$
(iii) $\sqrt[n]{\frac{a}{b}} = \frac{\sqrt[n]{a}}{\sqrt[n]{b}}$	(iii) $\left(\frac{a}{b}\right)^{\frac{1}{n}} = \frac{a^{\frac{1}{n}}}{b^{\frac{1}{n}}}$
(iv) $(\sqrt[n]{a})^m = \sqrt[n]{a^m}$	(iv) $\left(a^{\frac{1}{n}}\right)^m = (a^m)^{\frac{1}{n}} = a^{\frac{m}{n}}$

Pure Surds:

A surd which has unity only as rational factor, the other factor being irrational, is called a pure surd.

Example: $\sqrt{2}$, $\sqrt{11}$, $\sqrt[4]{3}$, are pure surds.

Mixed Surds:

A surd which has rational factor other than unity, the other factor being irrational, is called a mixed surd.

Example: $2\sqrt{3}$, $5\sqrt{7}$, are mixed surds.

1.3.2 Surds of Second Order:

$\sqrt{a} = a^{\frac{1}{2}}$ is a surd of order 2, i.e. a quadratic surd.

Remark:

The symbol $\sqrt{\quad}$ is called the radical sign of index 2.

Similar Surds:

Surds having the same irrational factor are called similar or like surds.

For example, $\sqrt{3}$, $5\sqrt{3}$, $\frac{1}{7}\sqrt{3}$ are similar surds.

Surds having no common irrational factor are known as **unlike surds**.

Example: $\sqrt{2}$, $3\sqrt{5}$, $2\sqrt{3}$ are unlike surds.

Addition And Subtraction of Surds:

Similar surds can be added and subtracted

Example: (i) $6\sqrt{3} + 5\sqrt{3} = (6 + 5)\sqrt{3} = 11\sqrt{3}$

(ii) $12\sqrt{5} + 4\sqrt{5} - 6\sqrt{5} = (12 + 4 - 6)\sqrt{5} = 10\sqrt{5}$

Multiplication and division of two surds:

Surds of the same order can be multiplied and divided according to following laws:

For any natural numbers 'm' and 'n'

$$(i) \sqrt{m} \times \sqrt{n} = \sqrt{mn} \quad (ii) \frac{\sqrt{m}}{\sqrt{n}} = \sqrt{\frac{m}{n}}$$

EXAMPLE-1

Simplify: $\sqrt{8} \times \sqrt{2}$

SOLUTION: We use the rule $\sqrt{m} \times \sqrt{n} = \sqrt{mn}$

$$\sqrt{8} \times \sqrt{2} = \sqrt{8 \times 2} = \sqrt{16} = 4$$

EXAMPLE-2

Simplify: $\sqrt{180} \div \sqrt{24}$

SOLUTION: $\sqrt{180} \div \sqrt{24} = \frac{\sqrt{180}}{\sqrt{24}} = \sqrt{\frac{180}{24}}$ [using $\frac{\sqrt{m}}{\sqrt{n}} = \sqrt{\frac{m}{n}}$]

$$= \sqrt{\frac{\cancel{2} \times \cancel{2} \times \cancel{3} \times 3 \times 5}{\cancel{2} \times \cancel{2} \times 2 \times \cancel{3}}}$$

$$= \sqrt{\frac{15}{2}}$$

Rationalizing the Denominator:

We can simplify a fraction by removing a square root from the denominator.

We can do this by multiplying the numerator and denominator by the same square root.

This process is called rationalizing the denominator.

EXAMPLE-1

Simplify these (a) $\frac{2}{\sqrt{3}}$ (b) $\frac{5}{7\sqrt{2}}$

SOLUTION: (a) Multiply by $\frac{\sqrt{3}}{\sqrt{3}}$

$$\frac{2}{\sqrt{3}} = \frac{2}{\sqrt{3}} \times \frac{\sqrt{3}}{\sqrt{3}} = \frac{2\sqrt{3}}{(\sqrt{3})^2} = \frac{2\sqrt{3}}{3}$$

(b) Multiply by $\frac{\sqrt{2}}{\sqrt{2}}$

$$\frac{5}{7\sqrt{2}} = \frac{5}{7\sqrt{2}} \times \frac{\sqrt{2}}{\sqrt{2}} = \frac{5\sqrt{2}}{7 \times 2} = \frac{5\sqrt{2}}{14}$$

Multiply: $(2 + \sqrt{3})(5 - \sqrt{3})$

SOLUTION: $(2 + \sqrt{3})(5 - \sqrt{3})$

$$= 2 \times 5 + 2 \times (-\sqrt{3}) + 5 \times \sqrt{3} + \sqrt{3}(-\sqrt{3})$$

$$= 10 - 2\sqrt{3} + 5\sqrt{3} - 3$$

$$= 7 + 3\sqrt{3}$$

EXAMPLE-3

Multiply: $(3\sqrt{5} - 5\sqrt{2})(4\sqrt{5} + 3\sqrt{2})$

SOLUTION: $(3\sqrt{5} - 5\sqrt{2})(4\sqrt{5} + 3\sqrt{2})$

$$= 12(\sqrt{5})^2 + 9\sqrt{5}\sqrt{2} - 20\sqrt{2}\sqrt{5} - 15(\sqrt{2})^2$$

$$= 12 \times 5 + 9\sqrt{10} - 20\sqrt{10} - 15 \times (2)$$

$$= 60 - 30 - 11\sqrt{10}$$

$$= 30 - 11\sqrt{10}$$

EXAMPLE-4

Express in the simplest form

(i) $\sqrt{288}$ (ii) $\sqrt{147}$ (iii) $\sqrt{36a^3}$

SOLUTION: (i) $\sqrt{288}$

$$= \sqrt{2 \times 2 \times 2 \times 2 \times 2 \times 3 \times 3}$$

$$= \sqrt{2 \times 2} \times \sqrt{2 \times 2} \times \sqrt{3 \times 3} \times \sqrt{2}$$

$$= 2 \times 2 \times 3 \times \sqrt{2}$$

$$= 12\sqrt{2}$$

2	288
2	144
2	72
2	36
2	18
3	9
3	3
	1

(ii) $\sqrt{147}$

$$= \sqrt{7 \times 7 \times 3}$$

$$= \sqrt{7 \times 7} \times \sqrt{3}$$

$$= 7\sqrt{3}$$

7	147
7	21
3	3
	1

(iii) $\sqrt{36a^3}$

$$= \sqrt{6 \times 6 \times a \times a \times a}$$

$$= \sqrt{6 \times 6} \times \sqrt{a \times a} \times \sqrt{a}$$

$$= 6 \times a \times \sqrt{a}$$

$$= 6a\sqrt{a}$$

1.4 RATIONALIZATION:

Binomial Surd:

An expression is called a binomial surd if it consists of two terms in which at least one term is a surd. For example:

$$a + b\sqrt{x}, \sqrt{x} + \sqrt{y} \text{ are binomial surds.}$$

Conjugate of Binomial Surds:

$$(i) \quad a + b\sqrt{x} \text{ and } a - b\sqrt{x}$$

$$(ii) \quad \sqrt{x} + \sqrt{y} \text{ and } \sqrt{x} - \sqrt{y}$$

are surds whose product is a rational number. The pair of such surds is called conjugate binomial surds. Each of these two surds is a conjugate of the other. For example:

$$(i) \quad 2 + 3\sqrt{5} \text{ is conjugate binomial surd of } 2 - 3\sqrt{5}.$$

$$(ii) \quad \sqrt{3} + \sqrt{7} \text{ is conjugate binomial surd of } \sqrt{3} - \sqrt{7}.$$

Remember that:

Conjugate binomial surds are rationalizing factors of each other.

Rationalizing Factor:

When the product of two surds is rational, then each one of them is called the rationalizing factor of the other.

EXAMPLE

$$(i) \quad 2\sqrt{3} \times \sqrt{3} = 6, \text{ which is rational.}$$

So $\sqrt{3}$ is rationalizing factor of $2\sqrt{3}$.

$$(ii) \quad (\sqrt{3} + \sqrt{2})(\sqrt{3} - \sqrt{2}) = 3 - 2 = 1 \text{ which is rational.}$$

So $(\sqrt{3} + \sqrt{2})$ is rationalizing factor of $(\sqrt{3} - \sqrt{2})$.

Rationalization of Surds:

The process of converting a surd to a rational number by multiplying it with a suitable rationalizing factor, is called the rationalization of the surds.

EXAMPLE-1

Express $\frac{1}{5+2\sqrt{3}}$ with rational denominator.

$$\begin{aligned}\text{SOLUTION: } \frac{1}{5+2\sqrt{3}} &= \frac{1}{5+2\sqrt{3}} \times \frac{5-2\sqrt{3}}{5-2\sqrt{3}} \\ &= \frac{5-2\sqrt{3}}{5^2-(2\sqrt{3})^2} \\ &= \frac{5-2\sqrt{3}}{25-12} = \frac{5-2\sqrt{3}}{13}\end{aligned}$$

EXAMPLE-2

Express $\frac{1}{\sqrt{5}+\sqrt{3}}$ with rational denominator.

$$\begin{aligned}\text{SOLUTION: } \frac{1}{\sqrt{5}+\sqrt{3}} &= \frac{1}{\sqrt{5}+\sqrt{3}} \times \frac{\sqrt{5}-\sqrt{3}}{\sqrt{5}-\sqrt{3}} \\ &= \frac{\sqrt{5}-\sqrt{3}}{(\sqrt{5})^2-(\sqrt{3})^2} \\ &= \frac{\sqrt{5}-\sqrt{3}}{5-3} = \frac{\sqrt{5}-\sqrt{3}}{2}\end{aligned}$$

$$(i) \frac{1}{x} \quad (ii) x + \frac{1}{x} \quad (iii) x - \frac{1}{x} \quad (iv) \left(x + \frac{1}{x}\right)^2$$

$$(v) \left(x - \frac{1}{x}\right)^2 \quad (vi) x^2 + \frac{1}{x^2} \quad (vii) x^2 - \frac{1}{x^2}$$

SOLUTION: $x = 3 + \sqrt{8}$

$$(i) \frac{1}{x} = \frac{1}{3 + \sqrt{8}}$$

$$= \frac{1}{3 + \sqrt{8}} \times \frac{3 - \sqrt{8}}{3 - \sqrt{8}}$$

$$= \frac{3 - \sqrt{8}}{(3)^2 - (\sqrt{8})^2} = \frac{3 - \sqrt{8}}{9 - 8}$$

$$= 3 - \sqrt{8}$$

$$(ii) x + \frac{1}{x}$$

$$= (3 + \sqrt{8}) + (3 - \sqrt{8})$$

$$= 3 + \sqrt{8} + 3 - \sqrt{8}$$

$$= 6$$

$$(iii) x - \frac{1}{x}$$

$$= (3 + \sqrt{8}) - (3 - \sqrt{8})$$

$$= 3 + \sqrt{8} - 3 + \sqrt{8}$$

$$= 2\sqrt{8}$$

$$(iv) \left(x + \frac{1}{x}\right)^2$$

$$\left(x + \frac{1}{x}\right)^2 = 6^2 \quad (\text{from (ii)})$$

$$\left(x + \frac{1}{x}\right)^2 = 36$$

$$(v) \left(x - \frac{1}{x}\right)^2$$

$$\left(x - \frac{1}{x}\right)^2 = (2\sqrt{8})^2 \quad (\text{from (iii)})$$

$$\left(x - \frac{1}{x}\right)^2 = 32$$

$$(vi) x^2 + \frac{1}{x^2}$$

$$= x^2 + \frac{1}{x^2} + 2 - 2$$

$$= \left(x^2 + \frac{1}{x^2} + 2\right) - 2$$

$$= \left(x + \frac{1}{x}\right)^2 - 2$$

$$= 36 - 2 \quad (\text{from (iv)})$$

$$= 34$$

$$(vii) x^2 - \frac{1}{x^2}$$

$$= \left(x + \frac{1}{x}\right) \left(x - \frac{1}{x}\right) = 6(2\sqrt{8}) \quad (\text{from (ii), (iii)})$$

$$= 12\sqrt{8}$$

EXERCISE - 1.3

1. Remove the radical sign from the denominator:

(i) $\frac{1}{\sqrt{5}}$ (ii) $\frac{2}{\sqrt{2}} \cdot \frac{7}{\sqrt{3}}$ (iii) $\frac{\sqrt{6}}{\sqrt{7}}$

2. Simplify the following expressions:

(i) $\sqrt{2} + \sqrt{8}$ (ii) $4\sqrt{50} + \sqrt{200} + \sqrt{50}$
(iii) $(\sqrt{12} - \sqrt{2})(\sqrt{20} - 3\sqrt{2})$ (iv) $(6 + \sqrt{2})(5 - \sqrt{5})$
(v) $(\sqrt{3} - 2)(5 - \sqrt{5})$ (vi) $(7 + \sqrt{3})(5 + \sqrt{2})$

3. Rationalize the denominators of the following :

(i) $\frac{1}{\sqrt{3} + 2}$ (ii) $\frac{1}{4 - \sqrt{5}}$ (iii) $\frac{4\sqrt{3}}{\sqrt{7} + \sqrt{5}}$ (iv) $\frac{\sqrt{x} - \sqrt{y}}{\sqrt{x} + \sqrt{y}}$

(v) $\frac{5\sqrt{7}}{2 + 3\sqrt{7}}$ (vi) $\frac{\sqrt{3} + \sqrt{2}}{\sqrt{3} - \sqrt{2}}$ (vii) $\frac{29}{11 + 3\sqrt{5}}$

(viii) $\frac{17}{3\sqrt{7} + 2\sqrt{3}}$

4. If $x = \sqrt{5} + 2$, then find the values of (i) $x + \frac{1}{x}$ and (ii) $x^2 + \frac{1}{x^2}$

5. If $x = 2 + \sqrt{3}$, then find the values of (i) $x - \frac{1}{x}$ and (ii) $x^2 + \frac{1}{x^2}$

6. If $x = \sqrt{3} - \sqrt{2}$, then find the values of (i) $x - \frac{1}{x}$ and (ii) $x^2 + \frac{1}{x^2}$

7. If $\frac{1}{x} = 3 - \sqrt{2}$, then evaluate (i) $x + \frac{1}{x}$ (ii) $x - \frac{1}{x}$

8. If $\frac{1}{p} = \sqrt{10} + 3$, then evaluate (i) $(p + \frac{1}{p})^2$ (ii) $(p - \frac{1}{p})^2$

9. Rationalize (i) $\frac{b + \sqrt{b^2 - a^2}}{b - \sqrt{b^2 - a^2}}$ (ii) $\frac{\sqrt{a+3} - \sqrt{a-3}}{\sqrt{a+3} + \sqrt{a-3}}$

Review Exercise-1

I- Encircle the Correct Answer.

1. An algebraic expression of the form $\frac{P(x)}{Q(x)}$, $Q(x) \neq 0$, $P(x)$ and $Q(x)$ are polynomials, is called a:
- (a) rational number (b) rational expression
(c) surd (d) mixed surd
2. $(a+b)^2 - (a-b)^2 = ?$
- (a) $2(a^2 + b^2)$ (b) $4ab$
(c) $-4ab$ (d) $a^2 + b^2$
3. $(a+b)^2 + (a-b)^2 = ?$
- (a) $-4ab$ (b) $a^2 + b^2$
(c) $4ab$ (d) $2(a^2 + b^2)$
4. $(a-b)(a^2 + ab + b^2) = ?$
- (a) $(a-b)^3$ (b) $(a+b)^3$
(c) $a^3 - b^3$ (d) $a^3 + b^3$
5. $(a+b)(a^2 - ab + b^2) = ?$
- (a) $a^3 - b^3$ (b) $(a+b)^3$
(c) $(a-b)^3$ (d) $a^3 + b^3$
6. $a^3 + 3ab(a+b) + b^3 = ?$
- (a) $(a+b)^3$ (b) $(a-b)^3$
(c) $a^3 + b^3$ (d) $a^3 - b^3$
7. $a^3 - 3ab(a-b) - b^3 = ?$
- (a) $a^3 + b^3$ (b) $(a+b)^3$
(c) $a^3 - b^3$ (d) $(a-b)^3$
8. An irrational number that contains radical signs is called a:
- (a) mixed surd (b) surd
(c) normal number (d) natural number

9. $\sqrt{a} = a^{1/2}$ is a surd of order:

- (a) zero (b) 1
(c) 2 (d) $\frac{1}{2}$

10. Surds can be multiplied, if they are of the

- (a) same order (b) order 2
(c) different order (d) order n

II- Fill in the blanks.

1. A number of the form $\frac{p}{q}$, $q \neq 0$, $p, q \in Z$ is called a _____.

2. An expression of the form $\frac{P(x)}{Q(x)}$, $Q(x) \neq 0$, $P(x), Q(x)$ are polynomials is called _____.

3. $(a+b)^2 - (a-b)^2 =$ _____

4. $(a+b)^2 + (a-b)^2 =$ _____

5. $a^3 + 3ab(a+b) + b^3 =$ _____

6. $a^3 - 3ab(a-b) - b^3 =$ _____

7. $(a-b)(a^2 + ab + b^2) =$ _____

8. $(a+b)(a^2 - ab + b^2) =$ _____

9. An irrational number that contains radical signs is called a _____.

10. $\sqrt{a} = a^{1/2}$ is a surd of order _____.

SUMMARY

Formulae:

$$(a \pm b)^2 = a^2 \pm 2ab + b^2$$

$$(a+b)^2 + (a-b)^2 = 2(a^2 + b^2)$$

$$(a+b)^2 - (a-b)^2 = 4ab$$

$$(a+b+c)^2 = a^2 + b^2 + c^2 + 2ab + 2bc + 2ac$$

$$(a \pm b)^3 = a^3 \pm 3ab(a \pm b) \pm b^3$$

$$a^3 + b^3 = (a+b)(a^2 - ab + b^2)$$

$$a^3 - b^3 = (a-b)(a^2 + ab + b^2)$$

Surd: A surd is an irrational number that contains radical signs.

Pure Surd: A surd which has unity only as rational factor, the other factor being irrational is called a pure surd.

Mixed surd: A surd which has rational factor other than unity, the other factor being irrational, is called mixed surd.

Similar surd: Surds having the same irrational factor are called similar or like surds.

Unlike surd: Surds having no common irrational factor are known as unlike surds.

Rationalizing Factor: When the product of two surds is rational, then each one of them is called the rationalizing factor of the other.

UNIT

2

FACTORIZATION

- ▶ Factorization
- ▶ Remainder Theorem and Factor Theorem
- ▶ Factorization of Cubic Polynomial

After completion of this unit, the students will be able to:

▶ factorize the expressions of following types.

• Type I: $kx + ky + kz,$

• Type II: $ax + ay + bx + by,$

• Type III: $a^2 \pm 2ab + b^2,$

• Type IV: $a^2 - b^2,$

• Type V: $(a^2 \pm 2ab + b^2) - c^2,$

• Type VI: $a^4 + a^2b^2 + b^4$ or $a^4 + 4b^4,$

• Type VII: $x^2 + px + q,$

• Type VIII: $ax^2 + bx + c,$

• Type IX:
$$\begin{cases} a^3 + 3a^2b + 3ab^2 + b^3, \\ a^3 - 3a^2b + 3ab^2 - b^3, \end{cases}$$

• Type X: $a^3 \pm b^3,$

- ▶ state and apply remainder theorem.
- ▶ find remainder (without dividing) when a polynomial is divided by a linear polynomial.
- ▶ define zeros of a polynomial.
- ▶ state factor theorem and explain through examples.
- ▶ use factor theorem to factorize a cubic polynomial.

2.1 FACTORIZATION OF EXPRESSIONS

Linear Polynomial :-

A polynomial of degree '1' is called a linear polynomial.
For example: $x + 3$, $2x - 5$ etc. The general form of linear polynomials is $ax + b$ where a, b are real numbers and $a \neq 0$.

Quadratic Polynomial :-

A polynomial of degree '2' is called quadratic polynomial e.g. $3x^2 + 5x - 2$, $4x^2 - 3x + 1$ etc. The general form of a quadratic polynomial is $ax^2 + bx + c$, where a, b, c are real numbers and $a \neq 0$.

Cubic Polynomial :-

A polynomial of degree '3' is called a cubic polynomial. e.g. $x^3 - 3x^2 + 5x + 2$, $4x^3 + 5x^2 - 2$ etc. The general form of cubic polynomial is $ax^3 + bx^2 + cx + d$ where a, b, c, d are real numbers and $a \neq 0$.

Let $P(x)$ be any polynomial and let a, b, c be any real numbers such that $P(x) = (x-a)(x-b)(x-c)$. Then, clearly each one of $(x-a)$, $(x-b)$, $(x-c)$ is a linear factor of $P(x)$.

To express a given polynomial as the product of linear factors or factors of degree less than that of the given polynomial, is known as factorization.

We see that in $15 = 3 \times 5$, 3 and 5 are factors of 15. Similarly, in $ax + ay = a(x + y)$, a and $(x + y)$ are factors of $ax + ay$ and in $ax + ay + az = a(x + y + z)$, a and $(x + y + z)$ are factors of $ax + ay + az$.

The process of writing an expression as a product of two or more factors is called factorization.

We factorize the expressions of different types.

Following examples will explain the factorization of the expression.

EXAMPLE-1

Factorize the following

(i) $3x + 12y$ (ii) $x^2 + xy$ (iii) $ad + dc + df$

(iv) $2pq + 6p^2q - 4p^3q$

SOLUTION:

(i) $3x + 12y = 3(x + 4y)$

(ii) $x^2 + xy = x(x + y)$

(iii) $ad + dc + df = d(a + c + f)$

(iv) $2pq + 6p^2q - 4p^3q = 2pq(1 + 3p - 2p^2)$

Factorization of the expression of the form:

$$ax + ay + bx + by$$

Following examples will explain the factorization of the expression.

EXAMPLE-2

Factorize the following expressions:

(i) $2ax + bx + 6ay + 3by$ (ii) $2yx + 18y^2 - 3zx + 27zy$

(iii) $5ym + 15yn + 2zm + 6zn$

SOLUTION:

(i) $2ax + bx + 6ay + 3by$
 $= x(2a + b) + 3y(2a + b)$
 $= (2a + b)(x + 3y)$

Now check $(2a + b)(x + 3y) = 2ax + bx + 6ay + 3by$

(ii) $2yx + 18y^2 + 3zx + 27zy$ (iii) $5ym + 15yn + 2zm + 6zn$
 $= 2y(x + 9y) + 3z(x + 9y)$ $= 5y(m + 3n) + 2z(m + 3n)$
 $= (2y + 3z)(x + 9y)$ $= (5y + 2z)(m + 3n)$

Factorization of the expression of the form:

$$a^2 \pm 2ab + b^2$$

We know that: (i) $a^2 + 2ab + b^2 = (a + b)^2$

$$(ii) a^2 - 2ab + b^2 = (a - b)^2$$

Expressions which have the pattern of the left hand side of (i) and (ii) are called perfect squares. These identities are useful in helping us to factorize certain expressions. Following examples will explain the factorization of the expressions.

EXAMPLE-3

Factorize the following.

$$(i) x^2 + 6x + 9 \quad (ii) t^2 - 12t + 36$$

$$\begin{aligned} \text{SOLUTION: (i)} \quad x^2 + 6x + 9 &= x^2 + 2(3)(x) + 3^2 \\ &= (x + 3)^2 \end{aligned}$$

$$\begin{aligned} (ii) \quad t^2 - 12t + 36 &= t^2 - 2(6)(t) + 6^2 \\ &= (t - 6)^2 \end{aligned}$$

Factorization of the expression of the form:

$$a^2 - b^2$$

This is called difference of two squares. $a^2 - b^2 = (a - b)(a + b)$

Following examples will explain the factorization of the expression:

EXAMPLE-4

Factorize the following.

$$(i) k^2 - 81 \quad (ii) 9a^2 - (b + c)^2$$

SOLUTION:

$$\begin{aligned} (i) \quad k^2 - 81 &= k^2 - 9^2 \\ &= (k + 9)(k - 9) \end{aligned}$$

$$\begin{aligned} (ii) \quad 9a^2 - (b + c)^2 &= (3a)^2 - (b + c)^2 \\ &= [3a + (b + c)][3a - (b + c)] \\ &= [3a + b + c][3a - b - c] \end{aligned}$$

EXAMPLE-5 Factorize $36d^2 - 1$

SOLUTION: $36d^2 - 1 = (6d)^2 - (1)^2$
 $= (6d + 1)(6d - 1)$

EXERCISE - 2.1

Factorize:

1- $3a(x + y) - 7b(x + y)$

2- $ax + ay - x^2 - xy$

3- $a^3 + a - 3a^2 - 3$

4- $x^3 + y - xy - x$

5- $3ax + 6ay - 8by - 4bx$

6- $2a^2 - bc - 2ab + ac$

7- $a(a - b + c) - bc$

8- $8 - 4a - 2a^3 + a^4$

9- $16x^2 - 24xa + 9a^2$

10- $1 - 14x + 49x^2$

11- $20x^2 + 5 - 20x$

12- $2a^3b + 2ab^3 - 4a^2b^2$

13- $x^2 + x + \frac{1}{4}$

14- $x^2 + \frac{1}{x^2} - 2$

15- $5x^3 - 30x^2 + 45x$

16- $a^2 + b^2 + 2ab + 2bc + 2ac$

Factorization of the expression of the form:

(i) $(a^2 + 2ab + b^2) - c^2$

(ii) $(a^2 - 2ab + b^2) - c^2$

Following examples will explain the factorization of the expressions.

EXAMPLE-1

Resolve into factors:

$$x^2 + 2xy + y^2 - 4z^2$$

SOLUTION: $(x^2 + 2xy + y^2) - 4z^2$

$$= (x + y)^2 - (2z)^2$$

$$= (x + y - 2z)(x + y + 2z)$$

EXAMPLE-2

Resolve into factors:

$$c^2 + 6bc + 9b^2 - 16x^2$$

SOLUTION:

$$\begin{aligned} (c^2 + 6bc + 9b^2) - 16x^2 \\ &= (c + 3b)^2 - (4x)^2 \\ &= (c + 3b + 4x)(c + 3b - 4x) \end{aligned}$$

EXAMPLE-3

Factorize:

(i) $a^2 - 2ab + b^2 - 9c^2$

(ii) $x^2 - 6xy + 9y^2 - 4z^2$

SOLUTION:

$$\begin{aligned} \text{(i) } a^2 - 2ab + b^2 - 9c^2 &= a^2 - 2ab + b^2 - 9c^2 \\ &= (a - b)^2 - (3c)^2 \\ &= (a - b - 3c)(a - b + 3c) \end{aligned}$$

$$\begin{aligned} \text{(ii) } x^2 - 6xy + 9y^2 - 4z^2 &= x^2 - 2(3)xy + 9y^2 - 4z^2 \\ &= (x - 3y)^2 - (2z)^2 \\ &= (x - 3y - 2z)(x - 3y + 2z) \end{aligned}$$

Factorization of the expression of the form:

(i) $a^4 + a^2b^2 + b^4$

(ii) $a^4 + 4b^4$

EXAMPLE-4Factorize: $x^4 + x^2 + 1$

$$\begin{aligned} \text{SOLUTION: } x^4 + x^2 + 1 &= x^4 + x^2 + 1 + x^2 - x^2 \\ &= (x^4 + 2x^2 + 1) - x^2 \\ &= (x^2 + 1)^2 - x^2 \\ &= (x^2 + x + 1)(x^2 - x + 1) \end{aligned}$$

SOLUTION:

$$\begin{aligned}
 x^4 + 64 &= (x^2)^2 + 8^2 + 2(8)x^2 - 2(8)x^2 \\
 &= (x^2 + 8)^2 - 16x^2 \\
 &= (x^2 + 8)^2 - (4x)^2 \\
 &= (x^2 + 8 + 4x)(x^2 + 8 - 4x)
 \end{aligned}$$

EXAMPLE-6

Resolve into factors:

$$x^4 + x^2y^2 + y^4$$

SOLUTION:

$$\begin{aligned}
 x^4 + x^2y^2 + y^4 &= (x^4 + 2x^2y^2 + y^4) - x^2y^2 \\
 &= (x^2 + y^2)^2 - (xy)^2 \\
 &= (x^2 + y^2 + xy)(x^2 + y^2 - xy)
 \end{aligned}$$

EXERCISE - 2.2

Resolve into Factors:

1. $x^2 + 2xy + y^2 - a^2$

2. $4a^2 + 4ab + b^2 - 9c^2$

3. $x^2 + 6ax + 9a^2 - 16b^2$

4. $y^2 - c^2 + 2cx - x^2$

5. $x^2 + y^2 + 2xy - 4x^2y^2$

6. $a^2 - 4ab + 4b^2 - 9a^2c^2$

7. $x^2 - 2xy + y^2 - a^2 + 2ab - b^2$

8. $y^4 + 4$

9. $z^4 + 64y^4$

10. $x^4 + 324$

11. $z^4 - z^2 + 16$

12. $4x^4 - 5x^2y^2 + y^4$

Factorization of the expression of the form:

$$x^2 + px + q$$

Let $x^2 + px + q = (x+r)(x+s)$

Then $x^2 + px + q = x^2 + (r+s)x + rs$

comparing coefficients of the like terms on both sides, we get

$$r + s = p \quad \text{and} \quad rs = q$$

Thus, in order to factorize $x^2 + px + q$, we have to find two numbers 'r' and 's' such that $r + s = p$ and $rs = q$

Following examples will explain the factorization of the expression.

EXAMPLE

Factorize

(i) $x^2 + 7x + 12$ (ii) $x^2 + 4x - 21$ (iii) $x^2 - 5x - 14$

SOLUTION:

(i) *In order to factorize $x^2 + 7x + 12$, we must find two numbers 'r' and 's' such that*

$$r + s = 7 \quad \text{and} \quad rs = 12$$

Clearly $4 + 3 = 7$ and $4 \times 3 = 12$

$$\begin{aligned} \therefore x^2 + 7x + 12 &= x^2 + 4x + 3x + 12 \\ &= x(x+4) + 3(x+4) \\ &= (x+4)(x+3) \end{aligned}$$

(ii) *In order to factorize $x^2 + 4x - 21$, we must find two numbers 'r' and 's' such that*

$$r + s = 4 \quad \text{and} \quad rs = -21$$

Clearly $7 + (-3) = 4$ and $7(-3) = -21$

$$\begin{aligned} \therefore x^2 + 4x - 21 &= x^2 + 7x - 3x - 21 \\ &= x(x+7) - 3(x+7) \\ &= (x+7)(x-3) \end{aligned}$$

Clearly $-7 + 2 = -5$ and $-7 \times 2 = -14$

$$\begin{aligned}\therefore x^2 - 5x - 14 &= x^2 - 7x + 2x - 14 \\ &= x(x-7) + 2(x-7) \\ &= (x-7)(x+2)\end{aligned}$$

Factorization of the expression of the form:

$$ax^2 + bx + c, a \neq 0$$

To factorize the expression of the form $ax^2 + bx + c$, we find numbers p and q such that $p + q = b$ and $pq = ac$ in the given expression, where a, b, c are constants and $a \neq 0$.

Following examples will explain the factorization of the expression.

EXAMPLE

Factorize: (i) $6x^2 + 7x - 3$ (ii) $\sqrt{3}x^2 + 11x + 6\sqrt{3}$

SOLUTION:

(i) The given expression $6x^2 + 7x - 3$,
is of the form $ax^2 + bx + c$, $ac = 6 \times (-3) = -18$

$$\begin{aligned}\therefore 6x^2 + 7x - 3 &= 6x^2 + 9x - 2x - 3 \\ &= 3x(2x + 3) - 1(2x + 3) \\ &= (2x + 3)(3x - 1)\end{aligned}$$

(ii) $\sqrt{3}x^2 + 11x + 6\sqrt{3}$; $ac = \sqrt{3} \times 6\sqrt{3} = 18$

Clearly $9 + 2 = 11$

$$\begin{aligned}\therefore \sqrt{3}x^2 + 11x + 6\sqrt{3} &= \sqrt{3}x^2 + 9x + 2x + 6\sqrt{3} \\ &= \sqrt{3}x[x + 3\sqrt{3}] + 2[x + 3\sqrt{3}] \\ &= (\sqrt{3}x + 2)(x + 3\sqrt{3})\end{aligned}$$

$$6 \times (-3) = -18$$

Possible Pairs

$$18 \times (-1) = -18$$

$$(-18) \times (1) = -18$$

$$6 \times (-3) = -18$$

$$-6 \times 3 = -18$$

$$-9 \times 2 = -18$$

$$9 \times (-2) = -18$$

Selected Pair

$$9 \times (-2) = -18$$

EXERCISE - 2.3

Factorize:

1. $x^2 + 9x + 20$

2. $x^2 + 5x - 14$

3. $x^2 + 5x - 6$

4. $x^2 - 7x + 12$

5. $x^2 - x - 156$

6. $x^2 - x - 2$

7. $x^2 - 9x - 90$

8. $a^2 - 12a - 85$

9. $98 - 7x - x^2$

10. $y^2 - 11y - 152$

11. $2x^2 + 3x + 1$

12. $3x^2 + 5x + 2$

13. $2x^2 - x - 1$

14. $6x^2 + 7x - 3$

15. $2 - 3x - 2x^2$

16. $8 + 6x - 5x^2$

17. $3u^2 - 10u + 8$

18. $10x^2 - 7x - 12$

19. $5x^2 - 32x + 12$

20. $4\sqrt{3}x^2 + 5x - 2\sqrt{3}$

Factorization of the expression, of the form:

$$\left\{ \begin{array}{l} a^3 + 3a^2b + 3ab^2 + b^3 \\ a^3 - 3a^2b + 3ab^2 - b^3 \end{array} \right\}$$

We know that:

(i) $(a + b)^3 = a^3 + 3a^2b + 3ab^2 + b^3$

(ii) $(a - b)^3 = a^3 - 3a^2b + 3ab^2 - b^3$

Following examples will explain the factorization of the expression.

EXAMPLE Factorize: (i) $x^3 + 6x^2 + 12x + 8$ (ii) $x^3 - 6x^2 + 12x - 8$

SOLUTION:

$$\begin{aligned} \text{(i) } x^3 + 6x^2 + 12x + 8 &= (x)^3 + 3(2)(x)^2 + 3(2)^2x + (2)^3 \\ &= (x + 2)^3 \end{aligned}$$

$$\begin{aligned} \text{(ii) } x^3 - 6x^2 + 12x - 8 &= (x)^3 - 3(2)(x)^2 + 3(2)^2x - (2)^3 \\ &= (x - 2)^3 \end{aligned}$$

$$a^3 \pm b^3$$

We know that

$$(i) \quad a^3 + b^3 = (a+b)(a^2 - ab + b^2)$$

$$(ii) \quad a^3 - b^3 = (a-b)(a^2 + ab + b^2)$$

Following examples will explain the factorization of the expression.

EXAMPLE-1

Factorize

$$(i) \quad x^3 + 27 \quad (ii) \quad 8a^3 - 125b^3 \quad (iii) \quad x^6 - y^6 \quad (iv) \quad a^3 - b^3 - a + b$$

SOLUTION:

$$\begin{aligned}(i) \quad x^3 + 27 &= x^3 + 3^3 \\ &= (x+3)(x^2 - 3x + 9)\end{aligned}$$

$$\begin{aligned}(ii) \quad 8a^3 - 125b^3 &= (2a)^3 - (5b)^3 \\ &= (2a-5b) [(2a)^2 + (2a) \times (5b) + (5b)^2] \\ &= (2a-5b) [4a^2 + 10ab + 25b^2]\end{aligned}$$

$$\begin{aligned}(iii) \quad x^6 - y^6 &= (x^3)^2 - (y^3)^2 \\ &= (x^3 + y^3)(x^3 - y^3) \\ &= (x+y)(x^2 - xy + y^2)(x-y)(x^2 + xy + y^2) \\ &= (x+y)(x-y)(x^2 - xy + y^2)(x^2 + xy + y^2)\end{aligned}$$

$$\begin{aligned}(iv) \quad a^3 - b^3 - a + b &= (a^3 - b^3) - (a - b) \\ &= (a-b)(a^2 + ab + b^2) - (a-b) \\ &= (a-b) [a^2 + ab + b^2 - 1]\end{aligned}$$

Remember that:

(i) $a^2 + 2ab + b^2 = (a + b)^2$

(ii) $a^2 - 2ab + b^2 = (a - b)^2$

(iii) $a^3 + 3a^2b + 3ab^2 + b^3 = (a + b)^3$

(iv) $a^3 - 3a^2b + 3ab^2 - b^3 = (a - b)^3$

(v) $(x + y)(x^2 - xy + y^2) = x^3 + y^3$

(vi) $(x - y)(x^2 + xy + y^2) = x^3 - y^3$

EXERCISE - 2.4**Factorize:**

1. $8x^3 - y^3$

2. $27x^3 + 1$

3. $1 - 343x^3$

4. $a^3b^3 + 512$

5. $27 - 1000y^3$

6. $27x^3 - 64y^3$

7. $x^3y^3 + z^3$

8. $216P^3 - 343$

9. $8x^3 - \frac{1}{27}$

10. $a^3 + b^3 + a + b$

11. $a - b - a^3 + b^3$

12. $x - 8xy^3$

13. $x^{12} - y^{12}$

14. $1 - \frac{64p^3}{q^3}$

15. $1 + 64U^3$

16. $8x^3 - 6x - 9y + 27y^3$

17. $z^3 + 125$

18. $x^9 + y^9$

19. $m^6 - n^6$

20. $64x^7 - xa^6$

21. $x^3 - 27a^3$

22. $x^3 + 27a^3$

$$P(x) = a_n x^n + a_{n-1} x^{n-1} + a_{n-2} x^{n-2} + \dots + a_1 x + a_0, \quad a_n \neq 0$$

where 'n' is a non-negative integer and the coefficients are constants, is called a polynomial function of degree 'n'.

For example:

(i) $P(x) = a_1 x + a_0$ (is a polynomial function of degree one), $a_1 \neq 0$

(ii) $P(x) = 3x^2 + 5x + 11$ (is a polynomial function of degree two)

(iii) $P(x) = 7x^5 + 2x^4 + 4x^3 + 7x^2 + 5x + 6$ (is a polynomial function of degree 5)

(iv) $P(x) = 5x^5 + \frac{7}{x} + 6 = 5x^5 + 7x^{-1} + 6$ (is not a polynomial function)

EXAMPLE

Divide $P(x) = 2x^4 + 3x^3 - x - 5$ by $x + 2$

SOLUTION:

$$\begin{array}{r}
 \begin{array}{l} \text{divisor} \end{array} \rightarrow x + 2 \overline{) \begin{array}{l} 2x^3 - x^2 + 2x - 5 \leftarrow \text{quotient} \\ 2x^4 + 3x^3 - x - 5 \leftarrow \text{dividend} \\ \hline \pm 2x^4 \pm 4x^3 \\ \hline -x^3 - x - 5 \\ \mp x^3 \qquad \mp 2x^2 \\ \hline 2x^2 - x - 5 \\ \pm 2x^2 \pm 4x \\ \hline -5x - 5 \\ \mp 5x \mp 10 \\ \hline 5 \leftarrow \text{remainder} \end{array}
 \end{array}$$

Remember that:

$$\text{Dividend} = \text{Divisor} \times \text{quotient} + \text{remainder}$$

2.2.1 The Remainder Theorem

If R is the remainder after dividing the polynomial $P(x)$ by $x - a$, then

$$P(a) = R$$

or

If a polynomial $P(x)$ of degree $n \geq 1$ is divided by polynomial $x - a$, where a is any constant, then remainder is $P(a)$, provided there is no term left containing 'x'.

EXAMPLE-1

If $P(x) = 4x^4 + 10x^3 + 19x + 5$, is divided by $x+3$, then find the remainder.

SOLUTION: $P(x) = 4x^4 + 10x^3 + 19x + 5$

$$x - a = x + 3 \Rightarrow a = -3$$

$$\begin{aligned}\text{Therefore } P(-3) &= 4(-3)^4 + 10(-3)^3 + 19(-3) + 5 \\ &= 4 \times 81 - 10 \times 27 - 57 + 5 \\ &= 324 - 270 - 57 + 5 \\ &= -3 + 5\end{aligned}$$

Thus $P(-3) = 2$

$$\boxed{R = 2}$$

EXAMPLE-2

If $P(x) = 5x^4 + 14x^3 + 3x^2 - 5x - 3$ is divided by $x - 1$, find the remainder.

SOLUTION: $P(x) = 5x^4 + 14x^3 + 3x^2 - 5x - 3$

$$x - a = x - 1 \Rightarrow a = 1$$

$$\begin{aligned}\text{Therefore } P(1) &= 5(1)^4 + 14(1)^3 + 3(1)^2 - 5(1) - 3 \\ &= 5 + 14 + 3 - 5 - 3 \\ &= 14\end{aligned}$$

Thus $P(1) = 14$

$$\boxed{R = 14}$$

2.2.2 Finding Remainder Without Dividing

In the following examples, we learn to find the remainder without division, when a polynomial is divided by a linear polynomial.

EXAMPLE-1

Use the remainder theorem to find the remainder when the first polynomial is divided by the second polynomial.

(i) $x^2 + 3x + 7$, $x + 1$ (ii) $x^3 - 2x^2 + 3x + 3$, $x - 3$

SOLUTION: (i) Let $P(x) = x^2 + 3x + 7$

Since the divisor $= x + 1$

$$\text{Therefore } x - a = x + 1 \Rightarrow a = -1.$$

By the remainder theorem

$$R = P(-1)$$

$$P(-1) = (-1)^2 + 3(-1) + 7$$

$$\text{Now } = 1 - 3 + 7$$

$$R = 5$$

(ii) Let $P(x) = x^3 - 2x^2 + 3x + 3$

$$x - a = x - 3 \Rightarrow a = 3$$

$$R = P(3)$$

$$\text{Now } P(3) = (3)^3 - 2(3)^2 + 3(3) + 3$$

$$= 27 - 18 + 9 + 3$$

$$\boxed{R = 21}$$

EXAMPLE-2

When $x^4 + 2x^3 + kx^2 + 3$ is divided by $x - 2$ the remainder is 1. Find the value of 'k'.

SOLUTION: Let $P(x) = x^4 + 2x^3 + kx^2 + 3$

Since the divisor $= x - 2$, therefore $x - a = x - 2 \Rightarrow a = 2$

$$\begin{aligned} \text{Now } P(2) &= (2)^4 + 2(2)^3 + k(2)^2 + 3 \\ &= 16 + 16 + 4k + 3 = 35 + 4k \end{aligned}$$

$$P(2) = 1 \text{ (given)}$$

$$1 = 35 + 4k \Rightarrow 4k = -34 \Rightarrow k = \frac{-17}{2}$$

2.2.3 Zeros of a Polynomial

If $P(x) = x - a_1$ and $Q(x) = x - a_2$ are any first degree polynomials such that $P(a_1) = 0$ and $Q(a_2) = 0$ for polynomials $P(x)$ and $Q(x)$.

Then a_1, a_2 are called zeros of $P(x)$ and $Q(x)$.

2.2.4 The Factor Theorem

If a polynomial $P(x)$ is divided by $x - a$ such that $P(a) = 0$, then $x - a$ is a factor of $P(x)$;

conversely, if $x - a$ is a factor of $P(x)$, then 'a' is zero of $P(x)$.

EXAMPLE-1

Use the factor theorem to determine if the first polynomial is a factor of the second polynomial.

$$x - 1, \quad x^2 + 4x - 5$$

SOLUTION: Let $P(x) = x^2 + 4x - 5$

$$x - a = x - 1$$

$$\Rightarrow a = 1$$

$$P(1) = 1^2 + 4(1) - 5$$

$$= 1 + 4 - 5$$

$$= 5 - 5$$

$$= 0$$

$$\text{Since } P(1) = 0$$

Thus by factor theorem, $x - 1$ is a factor of $x^2 + 4x - 5$

EXAMPLE-2

Use the factor theorem to show that $x + 1$ is a factor of $P(x) = x^{25} + 1$

SOLUTION: By direct substitution we see that -1 is a zero of $P(x)$

$$P(x) = x^{25} + 1$$

$$\begin{aligned} P(-1) &= (-1)^{25} + 1 \quad \therefore (-1)^{\text{odd}} = -1 \\ &= -1 + 1 \\ &= 0 \end{aligned}$$

Since -1 is a zero of $P(x) = x^{25} + 1$,

The linear polynomial $x - (-1) = x + 1$ is,

by the factor theorem, a factor of $x^{25} + 1$.

EXAMPLE-3

Use the factor theorem to show that $x - 1$ is not a factor of $4x^7 - 2x^6 + x^2 + 2x + 5$?

SOLUTION: Let $P(x) = 4x^7 - 2x^6 + x^2 + 2x + 5$

$$x - a = x - 1 \Rightarrow a = 1$$

$$\begin{aligned} P(1) &= 4(1)^7 - 2(1)^6 + 1^2 + 2(1) + 5 \\ &= 4 - 2 + 1 + 2 + 5 \\ &= 10 \neq 0 \end{aligned}$$

Then by factor theorem $x - 1$ is not a factor of $4x^7 - 2x^6 + x^2 + 2x + 5$

EXAMPLE-4

Use the factor theorem to show that $x+1$ is not a factor of $2x^5 - 5x^2 - x + 4$

SOLUTION: Let $P(x) = 2x^5 - 5x^2 - x + 4$

$$x - a = x + 1 \Rightarrow a = -1$$

$$\begin{aligned} P(-1) &= 2(-1)^5 - 5(-1)^2 - (-1) + 4 \\ &= -2 - 5 + 1 + 4 \end{aligned}$$

$$P(-1) = -2 \neq 0$$

$x + 1$ is not a factor of $2x^5 - 5x^2 - x + 4$.

2.3 FACTORIZING A CUBIC POLYNOMIAL

In order to factorize a cubic polynomial, we see the following examples:

EXAMPLE-1

Factorize the following

$$x^3 - x^2 - 10x + 10; x - 1$$

SOLUTION: $P(x) = x^3 - x^2 - 10(x) + 10; x - 1$

$$x - a = x - 1 \Rightarrow a = 1$$

$$P(1) = 1^3 - 1^2 - 10 + 10$$

$$= 0, \text{ therefore } x - 1 \text{ is a factor of } P(x)$$

$$x^2 - 10$$

Now $x - 1 \overline{) x^3 - x^2 - 10x - 10}$

$$\underline{-x^3 + x^2}$$

$$-10x + 10$$

$$\underline{+10x - 10}$$

$$0$$

Now $P(x) = \text{quotient} \times \text{divisor}$

Thus $x^3 - x^2 - 10x + 10 = (x - 1)(x^2 - 10)$

EXAMPLE-2

Factorize the following $x^3 - 8; x - 2$

SOLUTION: $P(x) = x^3 - 8, x - a = x - 2 \Rightarrow a = 2$

$$P(2) = 2^3 - 8 = 8 - 8$$

$$= 0, \text{ therefore } x - 2 \text{ is a factor of } P(x)$$

$$x^2 + 2x + 4$$

Now $x - 2 \overline{) x^3 - 8}$

$$\underline{-x^3 + 2x^2}$$

$$2x^2 - 8$$

$$\underline{-2x^2 + 4x}$$

$$4x - 8$$

$$\underline{-4x + 8}$$

$$0$$

Now $P(x) = x^3 - 8$

$$= (x - 2)(x^2 + 2x + 4)$$

EXERCISE - 2.5

I- Evaluate each of the polynomials for the value indicated.

1. $P(x) = 2x^3 - 5x^2 + 7x - 7; P(2)$

2. $P(x) = x^4 - 10x^2 + 25x - 2; P(-4)$

3. $P(x) = x^4 + 5x^3 - 13x^2 - 30; P(-1)$

4. $P(x) = x^5 - 10x^3 + 7x + 6; P(3)$

5. $P(x) = x^4 + 4x^3 - 9x^2 + 19x + 6; P(-2)$

II- Determine whether the second polynomial is a factor of the first polynomial without dividing (Hint: evaluate directly and use the factor theorem).

6. $x^{18} - 1; x + 1$

7. $x^{18} - 1; x - 1$

8. $x^9 - 2^9; x + 2$

9. $x^9 + 2^9; x - 2$

10. $3x^4 - 2x^3 + 5x - 6; x - 1$

11. $5x^6 - 7x^3 - 6x + x; x - 1$

12. $3x^3 - 7x^2 - 8x + 2; x + 1$

13. $5x^8 - 2x^5 + 3x^3 + 6x + 2; x + 1$

14. $6x^3 + 2x^2 - x + 9; x - 1$

15. $4x^3 - 3x^2 - 8x + 4; x - 2$

16. $5x^3 + 3x^2 - x + 1; x + 1$

17. $2y^3 - 8y^2 + y - 4; y - 4$

18. $z^3 - 5z^2 - 4z - 4; z + 2$

III- Solve.

19. If $P(x) = x^3 - kx^2 + 3x + 5$ is divided by $x - 1$, find k , if remainder is 8.

20. If $P(x) = 3x^3 + kx - 26$ is divided by $x - 2$, find k , if remainder is 0.

Review Exercise-2

I- Encircle the Correct Answer.

1. A linear polynomial is of degree =

- (a) 0 (b) 1
(c) 2 (d) 3

2. A quadratic polynomial is of degree =

- (a) 0 (b) 1
(c) 2 (d) 3

3. A cubic polynomial is of degree =

- (a) 0 (b) 1
(c) 2 (d) 3

4. Factorization of $(x+3)^2 - 4$ is

- (a) $(x+1)(x+5)$ (b) $(x-1)(x+5)$
(c) $(x+1)(x-5)$ (d) $(x-1)(x-5)$

5. Factorization of $x^4 - 16$ is

- (a) $(x-2)(x+2)$ (b) $(x-4)(x+4)$
(c) $(x-2)(x+2)(x^2+4)$ (d) $(x-2)(x+4)$

6. Factorization of $x^3 - y^3$ is =

- (a) $(x-y)(x^2+y^2)$ (b) $(x-y)(x^2+xy+y^2)$
(c) $(x-y)(x^2-xy+y^2)$ (d) $(x+y)(x^2+xy+y^2)$

7. Factorization of $a^4 - 1$ is =

- (a) $(a-1)(a+1)(a^2+1)$ (b) $(a-1)(a^2+1)$
(c) $(a+1)(a^2-1)$ (d) $(a^2+1)(a+1)$

8. If a polynomial $P(x)$ of degree $n \geq 1$ is divided by polynomial ' $x-a$ ', where a is any constant, then $P(a)$ is

- (a) remainder (b) zero
(c) 1 (d) a

9. If $x - a$ is a factor of $P(x)$, then $P(a) =$

- (a) 0 (b) 1
(c) $-a$ (d) a

10. If $P(x) = x^3 - 2x^2 + 5x + 1$, then $P(1) =$

- (a) 5 (b) -5
(c) -7 (d) 0

II- Fill in the blanks.

1. A linear polynomial is of degree _____.
2. A quadratic polynomial is of degree _____.
3. A cubic polynomial is of degree _____.
4. Factorization of $x^2 - 9$ is _____.
5. Factorization of $(x+2)^2 - 1$ is _____.
6. Factorization of $x^3 + 8$ is _____.
7. Factorization of $x^3 - 8$ is _____.
8. If $P(x) = x^4 + 3x^2 - 2x + 1$ is divided by $x - 1$, then $P(1) =$ _____.
9. If $P(x) = x^3 + 3x^2 - 3x + 1$ is divided by $x + 2$, then $P(-2) =$ _____.
10. If $P(x) = x^3 - a^3$ is divided by $x - a$, then $P(a) =$ _____.

SUMMARY

Linear Polynomial: A polynomial of degree "1" is called linear polynomial.

Quadratic Polynomial: A polynomial of degree "2" is called quadratic polynomial.

Cubic Polynomial: A polynomial of degree "3" is called cubic polynomial.

Factorization of following types of polynomials:

$$kx + ky + kz, ax + ay + bx + by, a^2 \pm 2ab + b^2$$

$$a^2 - b^2, (a^2 \pm 2ab + b^2) - c^2, a^4 + a^2b^2 + b^4 \text{ or } a^4 + 4b^4,$$

$$x^2 + px + q, ax^2 + bx + c,$$

$$a^3 + 3a^2bx + 3ab^2 + b^3, a^3 - 3a^2b + 3ab^2 - b^3,$$

$$a^3 \pm b^3.$$

Remainder Theorem: If a polynomial $P(x)$ of degree $n \geq 1$ is divided by a polynomial ' $x-a$ ' where ' a ' is any constant, then remainder is $P(a)$.

Factor Theorem: If a polynomial $P(x)$ is divided by ' $x-a$ ' such that $P(a) = 0$, then ' $x-a$ ' is a factor of $P(x)$.

UNIT

3

ALGEBRAIC MANIPULATION

- ▶ **H.C.F and L.C.M**
- ▶ **Basic Operations on Algebraic Fractions**
- ▶ **Square Roots of Algebraic Fractions**

After completion of this unit, the students will be able to:

- ▶ find highest common factor (HCF) and least common multiple (LCM) of algebraic expressions.
- ▶ use factor or division method to determine HCF and LCM.
- ▶ know the relationship between HCF and LCM.
- ▶ use HCF and LCM to reduce fractional expressions involving $+$, $-$, \times , \div .
- ▶ find square root of an algebraic expression by factorization and division.

3.1 HIGHEST COMMON FACTOR (H.C.F) AND LEAST COMMON MULTIPLE (L.C.M)

3.1.1 Highest Common Factor (H.C.F)

The highest common factor of two or more algebraic expressions is the expression of highest degree which divides each of them without remainder.

The abbreviation of the words **highest common factor** is **H.C.F.**

We can find the *H.C.F* of two or more than two algebraic expressions by the following two methods:

- (i) Factorization
- (ii) Division

H.C.F BY FACTORIZATION METHOD:

Method of finding highest common factor by factorization is explained by the following examples:

EXAMPLE-1

Find the *H.C.F* of $12p^3q^2$, $8p^2qr^3$ and $4p^2q^3r$

SOLUTION:

Factorization of $12p^3q^2 = 2 \times 2 \times 3 \times p \times p \times p \times q \times q$

Factorization of $8p^2qr^3 = 2 \times 2 \times 2 \times p \times p \times q \times r \times r \times r$

Factorization of $4p^2q^3r = 2 \times 2 \times p \times p \times q \times q \times q \times r$

Common factors are: $2 \times 2 \times p \times p \times q$

Thus $H.C.F = 4p^2q$

EXAMPLE-2

Find H.C.F of $2x^2 + 3x + 1$, $2x^2 + 5x + 2$ and $2x^2 - x - 1$

SOLUTION:

$$\begin{aligned} \text{Factorization of } 2x^2 + 3x + 1 &= 2x^2 + 2x + x + 1 \\ &= 2x(x+1) + 1(x+1) \\ &= (2x+1)(x+1) \end{aligned}$$

$$\begin{aligned} \text{Factorization of } 2x^2 + 5x + 2 &= 2x^2 + 4x + x + 2 \\ &= 2x(x+2) + 1(x+2) \\ &= (2x+1)(x+2) \end{aligned}$$

$$\begin{aligned} \text{Factorization of } 2x^2 - x - 1 &= 2x^2 - 2x + x - 1 \\ &= 2x(x-1) + 1(x-1) \\ &= (2x+1)(x-1) \end{aligned}$$

$$\text{Common factor} = 2x+1$$

$$\text{Thus H.C.F} = 2x+1$$

EXAMPLE-3

Find H.C.F of $24(6x^4 - x^3 - 2x^2)$ and $20(2x^6 + 3x^5 + x^4)$

$$\begin{aligned} \text{SOLUTION: Let } P(x) &= 24(6x^4 - x^3 - 2x^2) \\ &= 24x^2(6x^2 - x - 2) \\ &= 24x^2[6x^2 - 4x + 3x - 2] \\ &= 24x^2[2x(3x-2) + 1(3x-2)] \\ P(x) &= 24x^2(2x+1)(3x-2) = 2^2 \times 2 \times 3 \times x^2(2x+1)(3x-2) \end{aligned}$$

$$\begin{aligned} \text{Also let } Q(x) &= 20(2x^6 + 3x^5 + x^4) \\ &= 20x^4[2x^2 + 3x + 1] \\ &= 20x^4(2x^2 + 2x + x + 1) \\ &= 20x^4[2x(x+1) + 1(x+1)] \\ &= 20x^4(x+1)(2x+1) \\ &= 2^2 \times 5 \times x^2 \times x^2(x+1)(2x+1) \end{aligned}$$

$$\text{Common factors} = 2^2 \times x^2 \times (2x+1)$$

$$\text{Thus H.C.F} = 4x^2(2x+1)$$

EXAMPLE-4

Find H.C.F of $x^2 - 4$, $x^2 - 7x + 10$ and $x^2 + x - 6$

SOLUTION: Factorization of $x^2 - 4 = (x - 2)(x + 2)$

Factorization of $x^2 - 7x + 10$

$$= x^2 - 5x - 2x + 10$$

$$= x(x - 5) - 2(x - 5)$$

$$= (x - 5)(x - 2)$$

Factorization of $x^2 + x - 6$

$$= x^2 + 3x - 2x - 6$$

$$= x(x + 3) - 2(x + 3)$$

$$= (x + 3)(x - 2)$$

Common factor = $x - 2$

Thus H.C.F = $x - 2$

EXERCISE - 3.1

Find H.C.F by Factorization.

1. $abxy, a^2bc$

2. $6pqr, 15qrs$

3. $8xy^2z^3, 12x^2y^2z^2$

4. $14a^2bc, 21ab^2$

5. $3x^5y^2, 12x^2y^4, 15x^3y^2$

6. $4abc^3, 8a^3bc, 6ab^3c$

7. $x^3 + 64, x^2 - 16$

8. $x^2 - y^2, x^4 - y^4, x^6 - y^6$

9. $t^2 - 9, (t + 3)^2, t^2 + t - 6$

10. $x^2 - x - 2, x^2 + x - 6, x^2 - 3x + 2$

11. $1 - x^2, x^3 + 1, 1 - x - 2x^2$

12. $x^3 - 8, x^2 - 7x + 10$

13. $x^2 + 3x + 2, x^2 + 4x + 3, x^2 + 5x + 4$

14. $x^4 + x^3 - 6x^2, x^4 - 9x^2, x^3 + x^2 - 6x$

15. $35a^2c^3b, 45a^3cb^2, 30ac^2b^3$

H.C.F BY DIVISION METHOD

In order to find the H.C.F by division method, arrange the given expressions in descending powers of the common variable. Divide the larger degree polynomial by another one. Get the remainder. Take the previous divisor as the dividend and this remainder as the divisor. Divide and get the remainder. Go on repeating the process till we get zero as the remainder. The last divisor is the required H.C.F.

EXAMPLE-1

Find the H.C.F of $(x^3 - x^2 + x - 1)$ and $(x^3 - x^2 - 3x + 3)$ by division method.

SOLUTION:

$$\begin{array}{r} x^3 - x^2 + x - 1 \quad | \quad x^3 - x^2 - 3x + 3 \\ \underline{-x^3 + x^2 + x - 1} \\ -4x + 4 = -4(x - 1) \end{array}$$

Now dividing $-4x + 4$ by -4 , we get $x - 1$

$$\begin{array}{r} x^2 + 1 \\ x - 1 \quad | \quad x^3 - x^2 + x - 1 \\ \underline{-x^3 + x^2} \\ x - 1 \\ \underline{-x + 1} \\ 0 \end{array}$$

Thus H.C.F = $x - 1$

Remember that:

H.C.F is not affected by multiplying or dividing the polynomials with any number during the process of finding H.C.F.

EXAMPLE-2

Find H.C.F of $2x^3 + 6x^2 + 5x + 2$, $5x^3 + 10x^2 - 3x - 6$ and $3x^3 + 6x^2 + 2x + 4$

SOLUTION:

$$\begin{array}{r}
 5 \\
 2x^3 + 6x^2 + 5x + 2 \overline{) 5x^3 + 10x^2 - 3x - 6} \\
 \underline{\times 2} \\
 10x^3 + 20x^2 - 6x - 12 \\
 \pm 10x^3 \pm 30x^2 \pm 25x \pm 10 \\
 \hline
 -10x^2 - 31x - 22
 \end{array}$$

Now dividing $-10x^2 - 31x - 22$ by -1 , we get $10x^2 + 31x + 22$

$$\begin{array}{r}
 x-1 \\
 10x^2 + 31x + 22 \overline{) 2x^3 + 6x^2 + 5x + 2} \\
 \underline{\times 5} \\
 10x^3 + 30x^2 + 25x + 10 \\
 \pm 10x^3 \pm 31x^2 \pm 22x \\
 \hline
 -x^2 + 3x + 10 \\
 \underline{\times 10} \\
 -10x^2 + 30x + 100 \\
 \mp 10x^2 \mp 31x \mp 22 \\
 \hline
 61x + 122
 \end{array}$$

Now dividing $61x + 122$ by 61 , we get $x + 2$

$$\begin{array}{r}
 10x + 11 \\
 x + 2 \overline{) 10x^2 + 31x + 22} \\
 \underline{\pm 10x^2 \pm 20x} \\
 11x + 22 \\
 \underline{\pm 11x \pm 22} \\
 0
 \end{array}$$

Now

$$\begin{array}{r}
 3x^2 + 2 \\
 x + 2 \overline{) 3x^3 + 6x^2 + 2x + 4} \\
 \underline{\pm 3x^3 \pm 6x^2} \\
 2x + 4 \\
 \underline{\pm 2x \pm 4} \\
 0
 \end{array}$$

Thus H.C.F = $x + 2$

EXAMPLE-3

If $x - a$ is the H.C.F. of $x^2 - x - 6$ and $x^2 + 3x - 18$ then find the value of a .

SOLUTION: Clearly, $(x - a)$ divides both $x^2 - x - 6$ and $x^2 + 3x - 18$, so $x = a$ makes both polynomials zero.

$$\text{i.e. } a^2 - a - 6 = 0 \text{ and } a^2 + 3a - 18 = 0$$

$$a^2 - a - 6 = a^2 + 3a - 18$$

$$4a = 12$$

$$a = 3$$

Divisor

A polynomial $D(x)$ is called a divisor of a polynomial $P(x)$, if

$$P(x) = D(x) \cdot Q(x) \text{ for some polynomial } Q(x).$$

For example:

$$\text{Let } P(x) = (x - 2)(x + 3) \text{ and } D(x) = x - 2,$$

then clearly $D(x)$ is a divisor of $P(x)$.

$$\text{Since } P(x) = (x - 2)(x + 3)$$

$$= D(x) \cdot Q(x), \text{ where } Q(x) = x + 3$$

EXERCISE - 3.2

Find the H.C.F by Division Method.

- $x^4 + x^2 + 1$, $x^4 + x^3 + x + 1$
- $6x^3 + 7x^2 - 9x + 2$, $8x^4 + 6x^3 - 15x^2 + 9x - 2$
- $4x^3 + 2x^2 - 6x$, $4x^3 - 8x + 4$
- $x^3 + 7x^2 + 12x$, $x^3 - 2x^2 - 15x$
- $x^3 - x^2 - x + 1$, $x^4 - 2x^3 + 2x - 1$
- $x^3 - x^2 - x - 2$, $x^3 + 3x^2 - 6x - 8$
- $x^2 + 3x - 4$, $x^3 - 2x^2 - 2x + 3$
- $3x^3 - 14x^2 + 9x + 10$, $15x^3 - 34x^2 + 21x - 10$
- $2x^4 + x^3 + 4x + 2$, $6x^3 + 5x^2 + x$, $2x^4 + 3x^3 + x^2 + 2x + 1$
- $x^3 + x^2 - 5x + 3$, $x^3 - 7x + 6$, $x^3 + 2x^2 - 2x + 3$

3.1.2 Least Common Multiple (L.C.M)

The least common multiple of two or more algebraic expressions is the expression of lowest degree which is divisible by each of them without remainder.

The abbreviation of the words **least common multiple** is **L.C.M.**

We can find the L.C.M by factorization method:

L.C.M BY FACTORIZATION:

To find L.C.M by factorization, consider the following examples:

EXAMPLE-1

Find L.C.M of $12p^3q^2$, $8p^2qr^3$ and $4p^2q^3r$.

SOLUTION:

$$\text{Factorization of } 12p^3q^2 = 2 \times 2 \times 3 \times p \times p \times p \times q \times q$$

$$\text{Factorization of } 8p^2qr^3 = 2 \times 2 \times 2 \times p \times p \times q \times r \times r \times r$$

$$\text{Factorization of } 4p^2q^3r = 2 \times 2 \times p \times p \times q \times q \times q \times r$$

L.C.M = Product of common factors \times product of uncommon factors

$$= (2^2 \times p^2 \times q^2 \times r) \times (2 \times 3 \times p \times q \times r^2)$$

$$= 4p^2q^2r \times 6pqr^2$$

$$= 4 \times 6 \times p^2 \times p \times q^2 \times q \times r \times r^2$$

$$\text{L.C.M} = 24p^3q^3r^3$$

Remember that:

Common factors are not repeated while taking product of common factors.

EXAMPLE-2

Find L.C.M of $18ab^2c^3$, $6ab^2c^3$ and $24ab^2c^2$.

SOLUTION:

$$\text{Factorization of } 18ab^2c^3 = 2 \times 3 \times 3 \times a \times b \times b \times c \times c \times c$$

$$\text{Factorization of } 6a^2bc^3 = 2 \times 3 \times a \times a \times b \times c \times c \times c$$

$$\text{Factorization of } 24ab^2c^2 = 2 \times 2 \times 2 \times 3 \times a \times b \times b \times c \times c$$

Thus L.C.M = Product of common factors \times product of uncommon factors

$$= (2 \times 3 \times a \times b^2 \times c^3) \times (2 \times 2 \times 3 \times a)$$

$$= (6ab^2c^3) \times (12a)$$

$$\text{L.C.M} = 72a^2b^2c^3$$

EXAMPLE-3Find L.C.M of $x^2 - 49$ and $x^2 - 4x - 21$

SOLUTION:

$$x^2 - 49 = x^2 - 7^2$$

$$= (x-7)(x+7)$$

and $x^2 - 4x - 21 = x^2 - 7x + 3x - 21$

$$= x(x-7) + 3(x-7)$$

$$= (x-7)(x+3)$$

Common factor $= x-7$

Product of uncommon factors $= (x+7)(x+3)$

L.C.M = Product of common factors \times product of uncommon factors

$$= (x-7) \times (x+7)(x+3)$$

$$= (x^2 - 7^2)(x+3)$$

$$= (x^2 - 49)(x+3)$$

$$L.C.M = x^3 + 3x^2 - 49x - 147$$

EXERCISE - 3.3**Find L.C.M by Factorization.**

- | | |
|---|---|
| 1. $21a^4x^3y$, $35a^2x^4y$, $28a^3xy^4$ | 2. $3a^4b^2c^3$, $5a^2b^3c^5$ |
| 3. $2ab$, $3ab$, $4ca$ | 4. x^2yz , xy^2z , xyz^2 |
| 5. $p^3q - pq^3$, $p^5q^2 - p^2q^5$ | 6. $x^3 + 64$, $x^2 - 16$ |
| 7. $x^2 - x - 2$, $x^2 + x - 6$, $x^2 - 3x + 2$ | 8. $y^2 - 9$, $(y+3)^2$, $y^2 + y - 6$ |
| 9. $1 - y^2$, $y^3 + 1$, $1 - y - 2y^2$ | 10. $x^2 - y^2$, $x^4 - y^4$, $x^6 - y^6$ |
| 11. $x^3 + 1$, $x^4 + x^2 + 1$, $(x^2 + x + 1)^2$ | 12. $x^3 + y^3$, $x^4 - y^4$, $x^6 + y^6$ |
| 13. $2x^2 + 5x + 3$, $x^2 + 2x + 1$, $2x^2 + 9x + 9$ | |
| 14. $x^4 + x^3 - 6x^2$, $x^4 - 9x^2$, $x^3 + x^2 - 6x$ | |
| 15. $x^2 + 4xy + 4y^2$, $x^2 + 3xy + 2y^2$, $x^2 + 2xy + y^2$ | |

3.1.3 Relationship between HCF and LCM

If A and B are two algebraic expressions and **H.C.F.** and **L.C.M** of these is represented by H and L respectively, then the relation among them can be expressed as:

$$\boxed{A \times B = H \times L}$$

It is called a formula between **L.C.M.** and **H.C.F.**

PROOF: Suppose that

$$\frac{A}{H} = x \quad \text{and} \quad \frac{B}{H} = y$$

$$A = Hx \quad \dots\dots\dots (i)$$

$$B = Hy \quad \dots\dots\dots (ii)$$

Since there is no common factor between x and y .

Therefore $L = H.x.y$

$$HL = H(H.x.y) \quad (\text{Multiplying both the sides by } H)$$

$$= (Hx).(Hy)$$

$$HL = A.B.$$

Important results:

$$(i) \quad L = \frac{A \times B}{H}$$

$$(ii) \quad H = \frac{A \times B}{L}$$

$$(iii) \quad A = \frac{H \times L}{B}$$

Note: If A and B are two algebraic expressions, then we find **H.C.F** first, before finding the **L.C.M.**

If **H.C.F** of two algebraic expressions is given, then we can find **L.C.M.**

EXAMPLE-1

L.C.M and H.C.F of two algebraic expressions is $(2x+1)(x^2-1)$ and $(2x+1)$ respectively. If one expression is $(x-1)(2x+1)$, then find the other.

SOLUTION: $L = (2x+1)(x^2-1)$

$$H = 2x+1$$

$$A = (x-1)(2x+1)$$

$$B = ?$$

We have that $A \times B = H \times L$

$$B = \frac{H \times L}{A}$$

$$= \frac{(2x+1)(x^2-1)(2x+1)}{(x-1)(2x+1)}$$

$$= \frac{(2x+1)(x+1)(x-1)(2x+1)}{(x-1)(2x+1)}$$

$$B = (2x+1)(x+1)$$

EXAMPLE-2

The H.C.F of two polynomials is $(x+3)$ and their L.C.M is x^3-7x+6 . If one of the polynomials is (x^2+2x-3) , then find the other.

SOLUTION: Let the required polynomial be B . Then:

$$A \times B = H \times L$$

$$B = \frac{H \times L}{A}$$

$$= \frac{(x+3)(x^3-7x+6)}{x^2+2x-3}$$

$$= (x+3)(x-2)$$

$$B = x^2+x-6$$

$$\begin{array}{r} x-2 \\ x^2+2x-3 \overline{) x^3-7x+6} \\ \underline{-x^3+3x} \quad \pm 2x^2 \\ -2x^2-4x+6 \\ \underline{+2x^2+4x+6} \\ 0 \end{array}$$

EXAMPLE-3

Product of two expressions is $x^4 + 3x^3 - 12x^2 - 20x + 48$ and their L.C.M is $x^3 + 5x^2 - 2x - 24$. Find their H.C.F.

SOLUTION: Given that $A \times B = x^4 + 3x^3 - 12x^2 - 20x + 48$

$$L = x^3 + 5x^2 - 2x - 24$$

$$H = ?$$

$$L \times H = A \times B$$

$$H = \frac{A \times B}{L}$$

$$H = \frac{x^4 + 3x^3 - 12x^2 - 20x + 48}{x^3 + 5x^2 - 2x - 24}$$

$$\begin{array}{r} x-2 \\ x^3 + 5x^2 - 2x - 24 \overline{) x^4 + 3x^3 - 12x^2 - 20x + 48} \\ \underline{\pm x^4 \pm 5x^3 \mp 2x^2 \mp 24x} \\ -2x^3 - 10x^2 + 4x + 48 \\ \underline{\mp 2x^3 \mp 10x^2 \pm 4x \pm 48} \\ 0 \end{array}$$

$$\therefore \text{H.C.F} = x - 2$$

Remember that:

The product of two algebraic expressions = L.C.M \times H.C.F

$$\text{L.C.M} = \frac{\text{product of two algebraic expressions}}{\text{H.C.F}}$$

$$\text{H.C.F} = \frac{\text{product of two algebraic expressions}}{\text{L.C.M}}$$

EXERCISE - 3.4

Find the H.C.F and L.C.M of the Following.

- $x^3 + x^2 + x + 1$, $x^3 - x^2 + x - 1$
- $x^3 - 3x^2 - 4x + 12$, $x^3 - x^2 - 4x + 4$
- $2x^3 + 2x^2 + x + 1$, $2x^3 - 2x^2 + x - 1$
- $6x^3 + 7x^2 - 9x + 2$, $8x^4 + 6x^3 - 15x^2 + 9x - 2$
- $3x^4 + 17x^3 + 27x^2 + 7x - 6$, $6x^4 + 7x^3 - 27x^2 + 17x - 3$
- $2x^4 + 3x^3 - 13x^2 - 7x + 15$, $2x^4 + x^3 - 20x^2 - 7x + 24$
- $x^4 - x^3 - x + 1$, $x^4 + x^3 - x - 1$
- $x^4 + x^3 + x + 1$, $x^4 + x^3 - x - 1$

Find the Required Polynomial.

- $A = x^2 - 5x - 14$, $H = x - 7$, $L = x^3 - 10x^2 + 11x + 70$, $B = ?$
- $B = 3x^2 + 14x + 8$, $H = 3x + 2$, $L = 6x^3 + 25x^2 + 2x - 8$, $A = ?$
- The product of two polynomials and their *L.C.M.* are $x^4 + 6x^3 - 3x^2 - 56x - 48$ and $x^3 + 2x^2 - 11x - 12$ respectively. Find their *H.C.F.*
- The product of two polynomials and their *L.C.M.* are $x^4 + 5x^3 - x^2 - 17x + 12$ and $x^3 + 6x^2 + 5x - 12$ respectively. Find their *H.C.F.*
- The product of two polynomials and their *H.C.F.* are $x^4 - 12x^3 + 53x^2 - 102x + 72$ and $x - 3$ respectively. Find *L.C.M.*
- The product of two polynomials and their *H.C.F.* is $x^4 - 5x^3 + 2x^2 + 20x - 24$ and $x + 2$ respectively. Find their *L.C.M.*
- One algebraic expression is $x^3 + 3x^2 - 4x - 12$ and other one is $x^3 + 5x^2 - 4x - 20$. Their *H.C.F.* is $x^2 - 4$. Find their *L.C.M.*
- One algebraic expression is $x^3 - x^2 + 2x - 2$ and other one is $x^3 - x^2 - 2x + 2$. Their *H.C.F.* is $x - 1$. Find their *L.C.M.*
- Prove that $H^3 + L^3 = A^3 + B^3$ where $H + L = A + B$
'H' and 'L' stand for *H.C.F* and *L.C.M* respectively and 'A,B' represent two polynomials.

3.2 BASIC OPERATIONS ON THE ALGEBRAIC FRACTIONS

3.2.1 Addition and Subtraction of the Algebraic Fractions

Addition and subtraction of the algebraic fractions are explained in the following examples.

EXAMPLE-1

Simplify $\frac{x^2 + 3x + 2}{x^2 - 2x - 8} + \frac{x^2 - 5x + 6}{x^2 - 7x + 12} - \frac{x^2 + x - 6}{x^2 - 6x + 8}$

SOLUTION: $\frac{x^2 + 3x + 2}{x^2 - 2x - 8} + \frac{x^2 - 5x + 6}{x^2 - 7x + 12} - \frac{x^2 + x - 6}{x^2 - 6x + 8}$

$$= \frac{x^2 + 2x + x + 2}{x^2 - 4x + 2x - 8} + \frac{x^2 - 3x - 2x + 6}{x^2 - 4x - 3x + 12} - \frac{x^2 + 3x - 2x - 6}{x^2 - 4x - 2x + 8}$$

$$= \frac{(x+2)(x+1)}{(x-4)(x+2)} + \frac{(x-3)(x-2)}{(x-4)(x-3)} - \frac{(x+3)(x-2)}{(x-4)(x-2)}$$

$$= \frac{x+1}{x-4} + \frac{x-2}{x-4} - \frac{x+3}{x-4}$$

$$= \frac{x+1+x-2-x-3}{x-4}$$

$$= \frac{x-4}{x-4} = 1$$

Remember that:

- (i) In the algebraic fractions, the numerators and denominators are polynomials.
- (ii) When we add or subtract these fractions, we reduce this to lowest terms.

EXAMPLE-2

Simplify $\frac{a+b}{a^2+ab+b^2} + \frac{1}{a-b} - \frac{ab}{a^3-b^3}$

SOLUTION: $\frac{a+b}{a^2+ab+b^2} + \frac{1}{a-b} - \frac{ab}{a^3-b^3}$

$$= \frac{(a-b)(a+b) + 1(a^2+ab+b^2) - ab}{a^3-b^3}$$

$$= \frac{a^2-b^2+a^2+ab+b^2-ab}{a^3-b^3}$$

$$= \frac{2a^2}{a^3-b^3}$$

3.2.2 Multiplication and Division of the Algebraic Fractions

If P, Q, R and S are algebraic expressions, then $\frac{P}{Q}$ and $\frac{R}{S}$ are called algebraic fractions, where $Q \neq 0, S \neq 0$.

Multiplication of algebraic fractions:

$$\frac{P}{Q} \times \frac{R}{S} = \frac{PR}{QS} \quad \text{where } Q \neq 0, S \neq 0.$$

Division of algebraic fractions.

$$\begin{aligned} \frac{P}{Q} \div \frac{R}{S} &= \frac{P}{Q} \times \frac{S}{R} \\ &= \frac{PS}{QR} \quad \text{where } Q \neq 0, S \neq 0. \end{aligned}$$

EXAMPLE-1

Simplify $\frac{b^2 - c^2 - a^2 + 2ac}{c^2 + a^2 - b^2 + 2ac} \times \frac{b^2 + c^2 - a^2 - 2bc}{a^2 - b^2 + c^2 - 2ac}$

SOLUTION: $\frac{b^2 - c^2 - a^2 + 2ac}{c^2 + a^2 - b^2 + 2ac} \times \frac{b^2 + c^2 - a^2 - 2bc}{a^2 - b^2 + c^2 - 2ac}$

$$= \frac{b^2 - (c^2 + a^2 - 2ac)}{(c^2 + a^2 + 2ac) - b^2} \times \frac{(b^2 + c^2 - 2bc) - a^2}{(a^2 + c^2 - 2ac) - b^2}$$

$$= \frac{b^2 - (a-c)^2}{(a+c)^2 - b^2} \times \frac{(b-c)^2 - a^2}{(a-c)^2 - b^2}$$

$$= \frac{[b^2 - (a-c)^2]}{(a+c-b)(a+c+b)} \times \frac{(b-c-a)(b-c+a)}{(-1)[b^2 - (a-c)^2]}$$

$$= \frac{-(b-c-a)(b-c+a)}{(a+c-b)(a+b+c)}$$

$$= \frac{(a+c-b)(a+b-c)}{(a+c-b)(a+b+c)} = \frac{a+b-c}{a+b+c}$$

EXAMPLE-2

Simplify $\frac{a^3 - b^3}{a^4 - b^4} \div \frac{a^2 + ab + b^2}{a^2 + b^2}$

SOLUTION: $\frac{a^3 - b^3}{a^4 - b^4} \div \frac{a^2 + ab + b^2}{a^2 + b^2}$

$$= \frac{a^3 - b^3}{a^4 - b^4} \times \frac{a^2 + b^2}{a^2 + ab + b^2}$$

$$= \frac{(a-b)(a^2 + ab + b^2)}{(a^2 + b^2)(a+b)(a-b)} \times \frac{a^2 + b^2}{a^2 + ab + b^2}$$

$$= \frac{1}{a+b}$$

EXERCISE - 3.5

Simplify:

1. $\frac{1}{a} + \frac{2}{a+1} - \frac{3}{a+2}$

2. $\frac{2a}{(x-2a)} - \frac{x-a}{x^2-5ax+6a^2} + \frac{2}{x-3a}$

3. $\frac{1}{a^2+1} - \frac{a^4}{a^2+1} + \frac{a^6}{a^2-1} - \frac{1}{a^2-1}$

4. $\frac{1}{x^2+x+1} - \frac{1}{x^2-x+1} + \frac{2x+1}{x^4+x^2+1}$

5. $\frac{a^2(b-c)}{(a+b)(a+c)} - \frac{b^2(c-a)}{(b+c)(b+a)} + \frac{c^2(a-b)}{(c+a)(c+b)}$

6. $\frac{1}{x-1} + \frac{1}{x+1} - \frac{x+2}{x^2+x+1} - \frac{x-2}{x^2-x+1}$

7. $\frac{a^2+ab+b^2}{a+b} + \frac{a^2-ab+b^2}{a-b}$

8. $\frac{x^4-y^4}{x^2-2xy+y^2} \times \frac{x-y}{x(x+y)} \div \frac{x^2+y^2}{x}$

9. $\frac{x^2-1}{x^2+x-2} \times \frac{x^3+8}{x^4+4x^2+16} \div \frac{x^2+x}{x^3+2x^2+4x}$

10. $\frac{a^3+64b^3}{a^2+20ab+64b^2} \div \frac{a^2-4ab+16b^2}{a^2+4ab+16b^2} \times \frac{a^2+12ab-64b^2}{a^3-64b^3}$

11. $\frac{a}{(a+b)^2-2ab} \times \frac{a^4-b^4}{(a+b)^3-3ab(a+b)} + \frac{(a+b)^2-4ab}{(a+b)^2-3ab}$

12. $\frac{a^2-1}{a^2-a-2} \div \frac{a^2+5a+6}{a^2-5a+6} \div \frac{a^2-4a+3}{a^2+4a+3}$

3.3 SQUARE ROOT OF AN ALGEBRAIC EXPRESSION

We can find the square root of an algebraic expression by

- (i) FACTORIZATION
- (ii) DIVISION

3.3.1 Square Root by Factorization Method

By this method we find the square root of the expressions which can be expressed as a complete square.

For example:

$$x^2 \pm 2xy + y^2 = (x \pm y)^2$$

$$\text{or } x^2 \pm 2xy + y^2 = [\pm(x \pm y)]^2$$

$$\text{or } \sqrt{x^2 \pm 2xy + y^2} = \pm(x \pm y)$$

Therefore, the square root of an algebraic expression consists of two expressions which are additive inverses to each other.

EXAMPLE-1

Find the square root of $49x^2 + 112xy + 64y^2$ by factorization.

SOLUTION: $49x^2 + 112xy + 64y^2$

$$= (7x)^2 + 2(7x)(8y) + (8y)^2$$

$$= (7x + 8y)^2$$

$$49x^2 + 112xy + 64y^2 = [\pm(7x + 8y)]^2$$

Taking square root of both the sides, we have

$$\sqrt{49x^2 + 112xy + 64y^2} = \pm(7x + 8y)$$

EXAMPLE-2

Find square root of $(x^2 + \frac{1}{x^2}) + 10(x + \frac{1}{x}) + 27$

SOLUTION: Let $x + \frac{1}{x} = z$,

$$(x + \frac{1}{x})^2 = z^2 \quad (\text{Squaring both sides})$$

$$x^2 + \frac{1}{x^2} + 2 = z^2$$

$$x^2 + \frac{1}{x^2} = z^2 - 2$$

$$\therefore (x^2 + \frac{1}{x^2}) + 10(x + \frac{1}{x}) + 27 = z^2 - 2 + 10z + 27$$

$$= z^2 + 10z + 25$$

$$= (z)^2 + 2(z)5 + (5)^2$$

$$= (z + 5)^2 \quad \left[\text{Putting } z = x + \frac{1}{x} \right]$$

$$= (x + \frac{1}{x} + 5)^2$$

$$(x^2 + \frac{1}{x^2}) + 10(x + \frac{1}{x}) + 27 = \left[\pm(x + \frac{1}{x} + 5) \right]^2$$

Taking square root of both the sides, we get

$$\sqrt{(x^2 + \frac{1}{x^2}) + 10(x + \frac{1}{x}) + 27} = \pm(x + \frac{1}{x} + 5)$$

EXAMPLE-3

Find square root of $x(x-1)(x-2)(x-3)+1$

SOLUTION: $x(x-1)(x-2)(x-3)+1$

$$= [x(x-3)] [(x-1)(x-2)] + 1$$

$$= [x^2 - 3x] [x^2 - 3x + 2] + 1$$

Put $x^2 - 3x = z$

$$x(x-1)(x-2)(x-3)+1 = z(z+2)+1$$

$$= z^2 + 2z + 1$$

$$= (z+1)^2$$

Now put $z = x^2 - 3x$

$$x(x-1)(x-2)(x-3)+1 = (x^2 - 3x + 1)^2$$

$$= [\pm(x^2 - 3x + 1)]^2$$

Taking square root of both the sides, we get

$$\sqrt{x(x-1)(x-2)(x-3)+1} = \pm(x^2 - 3x + 1)$$

EXAMPLE-4

Find square root of $(\frac{x}{y} + \frac{y}{x})^2 - 4(\frac{x}{y} - \frac{y}{x})$, ($x \neq 0, y \neq 0$)

SOLUTION: Let $\frac{x}{y} - \frac{y}{x} = z$

$$\left(\frac{x}{y} - \frac{y}{x}\right)^2 = z^2 \quad (\text{Squaring both the sides})$$

$$\frac{x^2}{y^2} + \frac{y^2}{x^2} - 2 = z^2$$

$$\frac{x^2}{y^2} + \frac{y^2}{x^2} = z^2 + 2$$

$$\left(\frac{x}{y} + \frac{y}{x}\right)^2 - 4\left(\frac{x}{y} - \frac{y}{x}\right) = \left(\frac{x^2}{y^2} + \frac{y^2}{x^2} + 2\right) - 4\left(\frac{x}{y} - \frac{y}{x}\right)$$

$$= z^2 + 2 + 2 - 4z$$

$$= z^2 - 4z + 4$$

$$= (z - 2)^2$$

$$= [\pm(z - 2)]^2 \quad \left[\text{Putting } z = \frac{x}{y} - \frac{y}{x} \right]$$

$$\left(\frac{x}{y} + \frac{y}{x}\right)^2 - 4\left(\frac{x}{y} - \frac{y}{x}\right) = \left[\pm\left(\frac{x}{y} - \frac{y}{x} - 2\right)\right]^2$$

Taking square root of both the sides

$$\sqrt{\left(\frac{x}{y} + \frac{y}{x}\right)^2 - 4\left(\frac{x}{y} - \frac{y}{x}\right)} = \pm\left(\frac{x}{y} - \frac{y}{x} - 2\right)$$

3.3.2 Square Root by Division Method

We explain the method of finding the square root by division method in the following examples.

EXAMPLE-1

Find the square root of $x^2 + y^2 + z^2 + 2xy + 2yz + 2xz$

SOLUTION:

$$\begin{array}{r}
 \\
x \\
2x + y \\
2x + 2y + z \\
\hline
x + y + z \\
\hline
x^2 + 2xy + 2xz + 2yz + y^2 + z^2 \\
\pm x^2 \\
\hline
2xy + 2xz + 2yz + y^2 + z^2 \\
\pm 2xy \qquad \qquad \pm y^2 \\
\hline
2xz + 2yz + z^2 \\
\pm 2xz \pm 2yz \pm z^2 \\
\hline
0
\end{array}$$

Required square roots are $\pm(x + y + z)$.

- (i) Write the given expression in descending order.
Take square root x of the 1st term x^2 .
On subtraction, remainder is $2xy + 2xz + 2yz + y^2 + z^2$
- (ii) Multiply 2 times the quotient x by y , which is equal to the 1st term of the remainder. Therefore by dividing the remainder with $2x + y$, we get the new remainder $2xz + 2yz + z^2$ and $x + y$ as quotient, which are the 1st two terms of the square root.
- (iii) Divide this remainder by sum of 2 times the quotient and z i.e $2x + 2y + z$.
We get the quotient $x + y + z$ and remainder zero.
Thus $\pm(x + y + z)$ are the required square roots.

EXAMPLE-2

Find square root of $(x^2 - \frac{1}{x^2})^2 - 12(x^2 - \frac{1}{x^2}) + 36$

SOLUTION: $(x^2 - \frac{1}{x^2})^2 - 12(x^2 - \frac{1}{x^2}) + 36$

$$= x^4 + \frac{1}{x^4} - 2 - 12x^2 + \frac{12}{x^2} + 36$$

$$= x^4 - 12x^2 + 34 + \frac{12}{x^2} + \frac{1}{x^4} \quad (\text{Writing in descending order})$$

$$\begin{array}{r}
 \cdot x^2 - 6 - \frac{1}{x^2} \\
 \hline
 x^2 \quad x^4 - 12x^2 + 34 + \frac{12}{x^2} + \frac{1}{x^4} \\
 \pm x^4 \\
 \hline
 2x^2 - 6 \quad -12x^2 + 34 + \frac{12}{x^2} + \frac{1}{x^4} \\
 \mp 12x^2 \pm 36 \\
 \hline
 2x^2 - 12 - \frac{1}{x^2} \quad -2 + \frac{12}{x^2} + \frac{1}{x^4} \\
 \mp 2 \pm \frac{12}{x^2} \pm \frac{1}{x^4} \\
 \hline
 \phantom{2x^2 - 12 - \frac{1}{x^2}} \quad 0
 \end{array}$$

Thus $\pm(x^2 - 6 - \frac{1}{x^2})$ is the required square root.

$$x^2 = a \Rightarrow x = \pm a \text{ and } x = \pm \sqrt{a} \Rightarrow x^2 = a$$

EXAMPLE-3

For making $x^4 - 12x^3 + 217x + 320$ a complete square,

- (i) What should be added? (ii) What should be subtracted?
 (iii) What should be the value of x ?

SOLUTION:

$$\begin{array}{r}
 x^2 - 6x - 18 \\
 x^2 \left| \begin{array}{l} x^4 - 12x^3 + 0x^2 + 217x + 320 \\ \hline \pm x^4 \\ \hline -12x^3 + 0x^2 + 217x + 320 \\ \mp 12x^3 \pm 36x^2 \\ \hline -36x^2 + 217x + 320 \\ \mp 36x^2 \pm 216x \pm 324 \\ \hline x - 4 \end{array} \right.
 \end{array}$$

- (i) By adding $-x + 4$, the expression will be a complete square.
 (ii) By subtracting $x - 4$, the expression will be a complete square.
 (iii) If $x - 4 = 0$ i.e. $x = 4$ then the expression will be a complete square.

EXAMPLE-4

For what value of l and m the expression

$4x^4 - 12x^3 + 25x^2 - lx + m$ is a complete square, where $x \neq 0$

SOLUTION:

$$\begin{array}{r}
 2x^2 - 3x + 4 \\
 2x^2 \left| \begin{array}{l} 4x^4 - 12x^3 + 25x^2 - lx + m \\ \hline \pm 4x^4 \\ \hline -12x^3 + 25x^2 \\ \mp 12x^3 \pm 9x^2 \\ \hline 16x^2 - lx + m \\ - 16x^2 \mp 24x \pm 16 \\ \hline (-l + 24)x + (m - 16) = \text{Remainder} \end{array} \right.
 \end{array}$$

The given expression will be a complete square, if for each value of l and m , the given expression $(-l + 24)x + (m - 16)$ is zero.

It will be possible only if:

$$-l + 24 = 0 \quad \text{and} \quad m - 16 = 0$$

$$l = 24 \quad \text{and} \quad m = 16$$

Thus for $l = 24$ and $m = 16$, the expression will be a complete square.

EXERCISE - 3.6

Find the Square Root of the Following.

- $16x^2 + 24xy + 9y^2$
- $(x^2 - 7x + 12)(x^2 - 9x + 20)(x^2 - 8x + 15)$
- $(x^2 + 8x + 7)(2x^2 - x - 3)(2x^2 + 11x - 21)$
- $x(x+2)(x+4)(x+6) + 16$
- $(2x+1)(2x+3)(2x+5)(2x+7) + 16$
- $(x^2 + \frac{1}{x^2}) - 10(x + \frac{1}{x}) + 27, x \neq 0$
- $(t - \frac{1}{t})^2 - 4(t + \frac{1}{t}) + 8, (t \neq 0)$
- $(x^2 + \frac{1}{x^2})^2 - 4(x + \frac{1}{x})^2 + 12, x \neq 0$
- $4x^4 + 12x^3 + 25x^2 + 24x + 16$
- $\frac{9x^2}{4y^2} - \frac{3x}{2y} - \frac{7}{4} + \frac{2y}{3x} + \frac{4x^2}{9y^2}, (x \neq 0, y \neq 0)$
- For what value of x , $x^4 + 4x^2 + x + \frac{8}{x^2} + \frac{4}{x^4}$ is a complete square, where $x \neq 0$
- If $x^4 + lx^3 + mx^2 + 12x + 9$ is a complete square then find the values of l and m .

Review Exercise-3

I- Encircle the Correct Answer.

1. $\frac{\text{Product of two expressions}}{\text{L.C.M}} = ?$

- (a) H.C.F (b) L.C.M
(c) L.C.M \times H.C.F (d) L.C.M + H.C.F

2. The number of methods to find L.C.M are:

- (a) 0 (b) 1 (c) 2 (d) 3

3. The number of methods to find the H.C.F are:

- (a) 4 (b) 1 (c) 2 (d) 3

4. H.C.F of $12pq$, $8p^2q$ is:

- (a) $4pq$ (b) $4p^2q^2$ (c) $4pq^2$ (d) $4p^2q$

5. H.C.F of $2x^2 + 3x + 1$, $2x^2 - x - 1$ is:

- (a) $2x - 1$ (b) $2x + 1$ (c) $x + 1$ (d) $x - 1$

6. H.C.F of $6pqr$, $15qrs$ is:

- (a) $3qr$ (b) $3pqr$ (c) $3pqrs$ (d) $15pqrs$

7. L.C.M of $12p^3q^2$, $8p^2q$ is:

- (a) $24pq^2$ (b) $24p^3q$ (c) $24p^3q^2$ (d) $12p^2q$

8. Product of two expressions =

- (a) H.C.F (b) L.C.M
(c) H.C.F \times L.C.M (d) H.C.F + L.C.M

9. $\frac{\text{Product of two expressions}}{\text{H.C.F}} =$

- (a) L.C.M (b) H.C.F
(c) 0 (d) L.C.M \times H.C.F

10. $\frac{\text{L.C.M} \times \text{H.C.F}}{\text{First Expression}} =$

- (a) second expression (b) 1 (c) H.C.F (d) L.C.M

SUMMARY

H.C.F:

The *H.C.F* of two or more algebraic expressions is the expression of highest degree which divides each of them without remainder.

L.C.M:

The least common multiple of two or more algebraic expressions is the expression of lowest degree which is divisible by each of them without remainder.

UNIT

4

LINEAR EQUATIONS AND INEQUALITIES

- ▶ **Linear Equations**
- ▶ **Equation Involving Absolute Value**
- ▶ **Linear Inequalities**
- ▶ **Solving Linear Inequalities**

After completion of this unit, the students will be able to:

- ▶ recall linear equation in one variable.
- ▶ solve linear equation with rational coefficients.
- ▶ reduce equations, involving radicals, to simple linear form and find their solutions.
- ▶ define absolute value.
- ▶ solve the equation, involving absolute value in one variable.
- ▶ define inequalities ($>$, $<$) and (\geq , \leq).
- ▶ recognize properties of inequalities (i.e. trichotomy, transitive, additive and multiplicative).
- ▶ solve linear inequalities with rational coefficients.

4.1 LINEAR EQUATIONS

A statement in which sign of equality "=" is used to link two algebraic expressions is called an equation. An equation involving only a linear polynomial is called a linear equation. Equation $ax + b = 0$, $a \neq 0$ is a linear equation in one variable in standard form.

For example:

$$(i) \quad 7x + 3 = 5$$

$$(ii) \quad \frac{3}{2}x + 4 = \frac{1}{3}$$

$$(iii) \quad \frac{1}{2}(t+3) - 2t = 5$$

$$(iv) \quad \frac{5}{3}y + 4 = \frac{y-2}{4}$$

4.1.1 Linear Equation in One Variable

Any equation that can be written in the form:

$$ax + b = 0, \quad a \neq 0 \dots \dots \dots (1)$$

where a and b are constants and x is a variable, is called a linear equation (or first degree equation) in one variable.

Equation (1) always has a solution:

$$ax + b = 0, \quad a \neq 0$$

$$ax = -b$$

$$x = \frac{-b}{a} \text{ is the solution of the equation (1)}$$

EXAMPLE

Verify that $x = 2$ is a root of the equation $5x - 12 = -2$

SOLUTION:

Substituting $x = 2$ in the given equation, we get

$$L.H.S = 5x - 12 = 5 \times (2) - 12$$

$$= 10 - 12 = -2 = R.H.S$$

RULES FOR SOLVING AN EQUATION:

- (i) Same quantity can be added or subtracted to both sides of an equation without changing the equality.
- (ii) Both sides of an equation may be multiplied by a same non-zero number without changing the equality.
- (iii) Both sides of an equation may be divided by a same non-zero number without changing the equality.
- (iv) **TRANSPOSITION:**

Any term of an equation may be taken to the other side with its sign changed, without effecting the equality, is called transposition.

EXAMPLE

Solve: $5x - 6 = 4x - 2$

SOLUTION: We have $5x - 6 = 4x - 2$

or $5x - 4x = -2 + 6$ [Transposing $4x$ to L.H.S and -6 to R.H.S]

Thus $x = 4$ is a solution of the given equation.

CHECK: Substituting $x = 4$ in the given equation, we get

$$\text{L.H.S} = 5 \times (4) - 6 = 20 - 6 = 14$$

$$\text{R.H.S} = 4 \times (4) - 2 = 16 - 2 = 14$$

$$\therefore \text{L.H.S} = \text{R.H.S}$$

Hence $x = 4$ is solution of the given equation.

4.1.2 Solution of a Linear Equation

Any value of the variable which makes the equation a true statement, is called the solution (or root of the equation).

Solving an equation means to find a value of the variable which satisfies the equation.

EXAMPLE-1

Solve: $3x + \frac{1}{5} = 2 - x$

SOLUTION: We have $3x + \frac{1}{5} = 2 - x$

or $3x + x = 2 - \frac{1}{5}$ (Transposing $-x$ to L.H.S and $\frac{1}{5}$ to R.H.S)

or $4x = \frac{9}{5}$

or $\frac{1}{4} \times 4x = \frac{1}{4} \times \frac{9}{5}$ (dividing both sides by 4)

$x = \frac{9}{20}$

Thus $x = \frac{9}{20}$ is solution of the given equation.

CHECK: Substituting $x = \frac{9}{20}$ in the given equation, we get

$$\text{L.H.S} = 3 \times \frac{9}{20} + \frac{1}{5} = \frac{27}{20} + \frac{1}{5} = \frac{31}{20}$$

$$\text{R.H.S} = 2 - \frac{9}{20} = \frac{31}{20}$$

$$\therefore \text{L.H.S} = \text{R.H.S}$$

Hence $x = \frac{9}{20}$ is solution of the given equation.

EXAMPLE-2

Solve: $2y + \frac{11}{4} = \frac{1}{3}y + 2$

SOLUTION: We have $2y + \frac{11}{4} = \frac{1}{3}y + 2$

$2y - \frac{1}{3}y = 2 - \frac{11}{4}$ (Transposing $\frac{1}{3}y$ to L.H.S and $\frac{11}{4}$ to R.H.S)

$\frac{5}{3}y = \frac{-3}{4}$

$\frac{3}{5} \times \frac{5y}{3} = \frac{3}{5} \times \left(\frac{-3}{4}\right)$ (Multiplying both sides by $\frac{3}{5}$)

$y = \frac{-9}{20}$

Thus, $y = \frac{-9}{20}$ is solution of the given equation.

CHECK: Substituting $y = \frac{-9}{20}$ in the given equation, we get

$$\text{L.H.S} = 2 \times \left(\frac{-9}{20}\right) + \frac{11}{4} = \frac{-9}{10} + \frac{11}{4} = \frac{37}{20}$$

$$\text{R.H.S} = \frac{1}{3} \times \left(\frac{-9}{20}\right) + 2 = \frac{-3}{20} + 2 = \frac{37}{20}$$

$$\therefore \text{L.H.S} = \text{R.H.S}$$

Hence $y = \frac{-9}{20}$ is solution of the given equation.

EXAMPLE-3

Solve: $\frac{1}{4}x + \frac{1}{6}x = \frac{1}{2}x + \frac{3}{4}$

SOLUTION: L.C.M of the denominators 4,6,2,4 is 12.

Multiplying both sides by 12, we get

$$3x + 2x = 6x + 9$$

$$\text{or } 5x = 6x + 9$$

$$\text{or } 6x - 5x = -9 \quad [\text{Transposing } 5x \text{ and } 9]$$

$$\text{or } x = -9$$

Thus $x = -9$ is solution of the given equation.

CHECK: Substituting $x = -9$ in the given equation, we get

$$\text{L.H.S} = \frac{1}{4} \times (-9) + \frac{1}{6} \times (-9) = \frac{-9}{4} - \frac{3}{2} = \frac{-15}{4}$$

$$\text{R.H.S} = \frac{1}{2} \times (-9) + \frac{3}{4} = \frac{-9}{2} + \frac{3}{4} = \frac{-15}{4}$$

$$\therefore \text{L.H.S} = \text{R.H.S}$$

Hence $x = -9$ is solution of the given equation.

EXAMPLE-4

Solve: $\frac{5x-4}{8} - \frac{x-3}{5} = \frac{x+6}{4}$

SOLUTION: We have $\frac{5x-4}{8} - \frac{x-3}{5} = \frac{x+6}{4}$

Multiplying both sides by 40, the L.C.M of 8,5,4, we get

$$5(5x-4) - 8(x-3) = 10(x+6)$$

$$\text{or } 25x - 20 - 8x + 24 = 10x + 60$$

$$\text{or } 17x + 4 = 10x + 60$$

$$\text{or } 17x - 10x = 60 - 4 \quad [\text{Transposing } 10x \text{ to L.H.S and } 4 \text{ to R.H.S}]$$

$$\text{or } 7x = 56$$

$$\text{or } x = \frac{56}{7} = 8 \quad [\text{Multiplying both sides by } \frac{1}{7}]$$

Thus $x = 8$ is solution of the given equation.

CHECK: Substituting $x = 8$ in the given equation, we get

$$\text{L.H.S} = \frac{5 \times 8 - 4}{8} - \frac{8 - 3}{5} = \frac{36}{8} - 1 = \frac{28}{8} = \frac{7}{2}$$

$$\text{R.H.S} = \frac{8 + 6}{4} = \frac{14}{4} = \frac{7}{2}$$

$$\therefore \text{L.H.S} = \text{R.H.S}$$

Hence $x = 8$ is solution of the given equation.

What we need to know ?

- How to solve linear equations with unknown values on both sides.
- How to interpret the terms in expressions and formulae.
- How to solve linear equations with negative signs in the equation.

EXAMPLE-5

Solve: $x - \left[2x - \frac{3x-4}{7} \right] = \frac{4x-27}{3} - 3$

SOLUTION: We have, $x - \left[2x - \frac{3x-4}{7} \right] = \frac{4x-27}{3} - 3$

By removing the brackets, we get,

$$x - 2x + \frac{3x-4}{7} = \frac{4x-27}{3} - 3$$

$$\text{or } -x + \frac{3x-4}{7} = \frac{4x-27}{3} - 3$$

Multiplying both sides by 21, the L.C.M of 7,3, we get

$$-21x + 3(3x-4) = 7(4x-27) - 63$$

$$\text{or } -21x + 9x - 12 = 28x - 189 - 63$$

$$\text{or } -12x - 12 = 28x - 252$$

$$\text{or } -12x - 28x = -252 + 12 \quad [\text{by Transposition}]$$

$$\text{or } -40x = -240$$

$$\text{or } x = 6 \quad [\text{dividing both sides by } -40]$$

Thus $x = 6$ is solution of the given equation.

CHECK: Substituting $x = 6$ in the given equation, we get

$$\begin{aligned} \text{L.H.S} &= 6 - \left[2 \times 6 - \frac{3 \times 6 - 4}{7} \right] = 6 - \left(12 - \frac{14}{7} \right) = 6 - (12 - 2) \\ &= 6 - 10 = -4 \end{aligned}$$

$$\text{R.H.S} = \frac{4 \times 6 - 27}{3} - 3 = \frac{-3}{3} - 3 = -1 - 3 = -4$$

$$\therefore \text{L.H.S} = \text{R.H.S}$$

Hence $x = 6$ is solution of the given equation.

What we need to know ?

- How to operate with negative sign present outside a bracket.

EXAMPLE-6

Solve: $0.3x + 0.4 = 0.28x + 1.16$

SOLUTION: We have $0.3x + 0.4 = 0.28x + 1.16$

$$\text{or } 0.3x - 0.28x = 1.16 - 0.4 \quad [\text{by Transposition}]$$

$$\text{or } 0.02x = 0.76$$

$$\text{or } x = \frac{0.76}{0.02} = \frac{76}{2} = 38$$

Thus $x = 38$ is solution of the given equation.

CHECK: By substituting $x = 38$ in the given equation, we get

$$\text{L.H.S} = 0.3 \times 38 + 0.4 = 11.4 + 0.4 = 11.8$$

$$\text{R.H.S} = 0.28 \times 38 + 1.16 = 10.64 + 1.16 = 11.8$$

$$\therefore \text{L.H.S} = \text{R.H.S}$$

Hence $x = 38$ is solution of the given equation.

EXAMPLE-7

Solve: $3x - 2(2x - 5) = 2(x + 3) - 8$

SOLUTION: We have $3x - 2(2x - 5) = 2(x + 3) - 8$

$$3x - 4x + 10 = 2x + 6 - 8$$

$$-x + 10 = 2x - 2$$

$$3x - 2 = 10$$

$$3x = 12$$

$$x = 4$$

Thus $x = 4$ is solution of the given equation.

CHECK: By substituting $x = 4$ in the given equation, we get

$$3(4) - 2(2 \times 4 - 5) = 2(4 + 3) - 8$$

$$12 - 2(8 - 5) = 2(7) - 8$$

$$12 - 6 = 14 - 8$$

$$6 = 6$$

Hence $x = 4$ is solution of the given equation.

4.1.3 Equations Involving Radicals

In solving an equation such as

$$\sqrt{x-1} = 5 \quad \dots\dots\dots(1)$$

Squaring both sides $x-1 = 25$

$$x = 26$$

which is solution of (1)

However, if we do the same thing to

$$\sqrt{x-1} = -5 \quad \dots\dots\dots(2)$$

$$x-1 = 25 \quad \text{(Squaring both sides)}$$

$$x = 26$$

which is not a solution of (2)

$$\text{Since } 5 \neq -5$$

Similarly , we note that

$$\{x \mid x=5\} = \{5\}$$

$$\{x \mid x^2 = 25\} = \{-5, 5\}$$

Where as we see that the solution set of $x = 5$ is a subset of the solution set of the equation.

We get by squaring each member of $x = 5$.

It is important to remember that any new equation obtained by raising both members of an equation to the same power may have solutions (called **extraneous solutions**). That are not solutions of the original equation. On the other hand, any solution of the original equation must be among those of the new equation.

Thus, every solution of the new equation must be checked in the original equation to eliminate the extraneous solutions.

For any natural numbers x and y

$$\sqrt{x} \times \sqrt{y} = \sqrt{xy}$$

or the other way round

$$\sqrt{xy} = \sqrt{x} \sqrt{y}$$

Equations involving radicals may have extraneous roots, which are not the solutions of the original equation.

EXAMPLE-1

Solve: $x + \sqrt{x-4} = 4$

SOLUTION: $x + \sqrt{x-4} = 4$

$$\sqrt{x-4} = 4-x \quad (\text{Isolating the radical on one side})$$

$$x-4 = 16-8x+x^2 \quad (\text{Squaring both sides})$$

$$x^2-9x+20=0 \quad (\text{Solving quadratic equation})$$

$$(x-5)(x-4)=0$$

$$x = 5, 4$$

Check to eliminate extraneous roots (if any)

$$x = 5 \quad , \quad x = 4$$

$$5 + \sqrt{5-4} = 4 \quad , \quad 4 + \sqrt{4-4} = 4$$

$$5 + 1 \neq 4 \quad , \quad 4 = 4$$

Therefore, $x = 5$
is not a solution

$x = 4$
is a solution

$$\therefore \text{Solution set} = \{4\}$$

What we need to know ?

- Some formulae have squares and square roots in them.
- Squares and square roots are the inverse of each other.
- To remove a square, take the square root of each side.
- To remove a square root, square each side.

EXAMPLE-2

Solve: $\sqrt{3x-2} - \sqrt{x} = 2$

SOLUTION: $\sqrt{3x-2} = 2 + \sqrt{x}$

$$3x - 2 = 4 + 4\sqrt{x} + x \quad (\text{Squaring both sides})$$

$$3x - x - 2 - 4 = 4\sqrt{x}$$

$$2x - 6 = 4\sqrt{x}$$

$$x - 3 = 2\sqrt{x} \quad (\text{Dividing both sides by 2})$$

$$x^2 - 6x + 9 = 4x \quad (\text{Again squaring both sides})$$

$$x^2 - 10x + 9 = 0$$

$$(x-9)(x-1) = 0$$

$$x = 1, 9$$

Check to eliminate extraneous solutions (if any)

$x = 1$,	$x = 9$
$\sqrt{3 \times 1 - 2} - \sqrt{1} = 2$,	$\sqrt{3 \times 9 - 2} - \sqrt{9} = 2$
$\sqrt{1} - \sqrt{1} = 2$,	$\sqrt{25} - 3 = 2$
$0 \neq 2$,	$5 - 3 = 2$

Therefore, $x = 1$
is not a solution

$x = 9$
is the solution

$$\therefore \text{Solution set} = \{9\}$$

Remember that:

$s = \sqrt{t+r}$: Remove the square root, square each side.

$s^2 = t+r$: Now subtract the 'r' from both sides.

$s^2 - r = t$ This can be written $t = s^2 - r$

EXERCISE - 4.1**Solve:**

1. (i) $3x + 20 = 44$

(ii) $\frac{4x}{5} - \frac{3x}{4} = 4$

(iii) $3x + 3(x+1) = 69$

(iv) $(90 - 9x) + 27 = 90 + 9$

2. $3(x+3) = 14+x$

3. $3(2x+5) = 25+x$

4. $9x-3 = 3(2x-8)$

5. $3(2x-1) = 5(x-1)$

6. $2(7x-6) = 3(1+3x)$

7. $\frac{10x-1}{2x+5} = 3$

8. $\frac{2x+1}{x+5} = 1$

9. $\frac{5x+3}{x+6} = 2$

10. $y-6+\sqrt{y} = 0$

11. $x = 15 - 2\sqrt{x}$

12. $m-13 = \sqrt{m+7}$

13. $\sqrt{5n+9} = n-1$

14. $3+\sqrt{2x-1} = 0$

15. $\sqrt{x+5}+7 = 0$

16. $\sqrt{2x-1} - \sqrt{x-4} = 2$

17. $\sqrt{x+1} = 3$

18. $\sqrt{2x-1} = 5$

19. $\sqrt{x-1} = 10$

20. $\sqrt{3x+4} = 7$

4.2 EQUATIONS INVOLVING ABSOLUTE VALUE

In this section, we learn to solve the linear equations involving absolute value.

4.2.1 Absolute Value:

For each real number x , the absolute value of x , denoted by $|x|$, is defined by the formula:

$$|x| = \begin{cases} x & \text{if } x > 0 \\ 0 & \text{if } x = 0 \\ -x & \text{if } x < 0 \end{cases}$$

For example:

$$|8| = 8$$

$$|-8| = -(-8) = 8$$

4.2.2 Equations Involving Absolute Value:

Using the above definition, we will not find it difficult to show that for $p > 0$,

$$|x| = p \Leftrightarrow x = \pm p$$

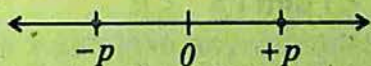

EXAMPLE

Solve (i) $|x| = 5$ (ii) $|x-3| = 5$ (iii) $|x+2| = 3$

SOLUTION:

(i) $|x| = 5 \Rightarrow x = \pm 5$

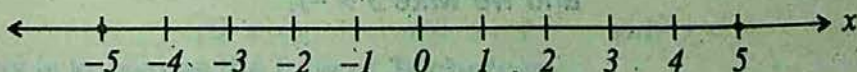

$$(ii) \quad |x-3| = 5 \Rightarrow x-3 = \pm 5$$

$$x-3 = 5 \quad \text{or} \quad x-3 = -5$$

$$x = 8 \quad \text{or} \quad x = -5+3$$

$$x = -2$$

$$x = -2 \quad \text{or} \quad 8$$

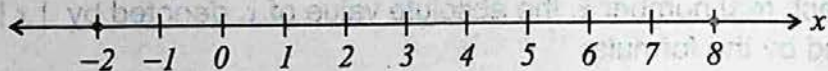

$$(iii) \quad |x+2| = 3 \Rightarrow x+2 = \pm 3$$

$$x+2 = 3 \quad \text{or} \quad x+2 = -3$$

$$x = 3-2 \quad \text{or} \quad x = -3-2$$

$$x = 1 \quad \text{or} \quad x = -5$$

$$x = 1 \quad \text{or} \quad -5$$

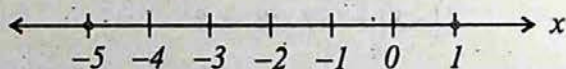

4.3 LINEAR INEQUALITIES

We know about ordering of numbers on the number line. A number on the number line is greater than any number on its left and less than any number on its right.

4.3.1 Inequalities ($>$, $<$) and (\geq , \leq):

We use the symbol ' $>$ ' to represent 'is greater than' and the symbol ' $<$ ' to represent 'is less than'.

For example:

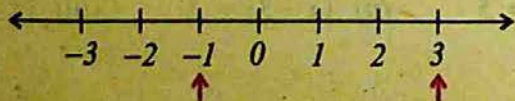

*3 lies on the right of -1, hence 3 is greater than -1
and we write $3 > -1$.*

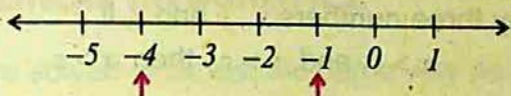

-4 lies on the left of -1 , hence -4 is less than -1
and we write $-4 < -1$.

We write $a < b$, read " a is less than b " if and only if there exists a positive real number p such that

$$a + p = b;$$

We write $a > b$, and read " a is greater than b ". We write $a \leq b$ if and only if $a < b$ or $a = b$ and we write $a \geq b$ if and only if $a > b$ or $a = b$

The symbols " $<$ ", " $>$ ", " \leq " and " \geq " are called **order relations or inequality symbols**.

Two algebraic expressions joined by an inequality symbol, such as $7(3x-2) + \frac{x}{5} < 2x - \frac{2}{3}$ is called an inequality statement or simply an inequality.

$x > 3$ means x can take any value greater than 3.

It cannot be 3. It is shown on the number line.

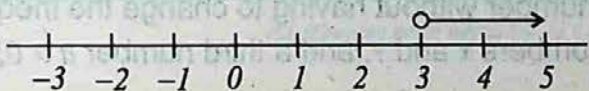

$x \leq 1$ means x can take any value less than or equal to 1.

This includes 1. It is shown on the number line.

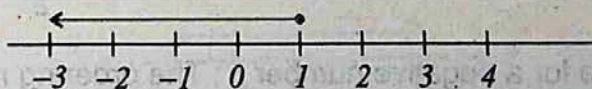

4.3.2 Properties of Inequalities

TRICHOTOMY: Consider any two numbers, x and y , on the number line. One and only one of the following statements must be true.

- (i) $x > y$ (ii) $x = y$ (iii) $x < y$

This is known as the **Law of Trichotomy**.

TRANSITIVE: For any three numbers x , y and z , if
 $x > y$ and $y > z$, then $x > z$

This is known as the **Transitive Property of Inequality**.

For example: If $x = 10$, $y = 5$ and $z = 2$,
 then $10 > 5$, $5 > 2$ and $10 > 2$

ADDITIVE: We can add or subtract a positive number from both sides of an inequality without any change in the inequality sign. For any two numbers x and y and a positive number ' a ',

If $x > y$ (e.g. $5 > 3$ and $2 > 0$),
 then $x + a > y + a$ (e.g. $5 + 2 > 3 + 2$)
 $x - a > y - a$ (e.g. $5 - 2 > 3 - 2$)

This is also true for a negative number b ;

If $x > y$ (e.g. $5 > 3$ and $-2 < 0$),
 then $x + b > y + b$ (e.g. $5 + (-2) > 3 + (-2)$)
 $x - b > y - b$ (e.g. $5 - (-2) > 3 - (-2)$)

MULTIPLICATIVE: We can multiply and divide both sides of an inequality by a positive number without having to change the inequality sign. For any two numbers x and y , and a third number $a > 0$,

If $x > y$ (e.g. $5 > 3$ and $2 > 0$),
 then $ax > ay$ (e.g. $2 \times 5 > 2 \times 3$) and $\frac{x}{a} > \frac{y}{a}$

This is not true for a negative number b ; The ordering relation is reversed when multiplied or divided by a negative number.

If $x > y$ and $b < 0$ (e.g. $5 > 3$ and $-2 < 0$),
 then $bx < by$ (e.g. $(-2) \times 5 < (-2) \times 3$)
 and $\frac{x}{b} < \frac{y}{b}$ (e.g. $\frac{5}{-2} < \frac{3}{-2}$)

4.4 SOLVING LINEAR INEQUALITIES:

Inequalities are solved in almost the same way as equations.

EXAMPLE-1

Solve the following inequalities

(i) $x+3 < 7$ (ii) $2x-1 > 5$ (iii) $6-x > 4$

SOLUTION:

(i) $x+3 < 7$

$$x+3-3 < 7-3 \quad (\text{Subtracting } 3 \text{ from both sides})$$

$$x < 4$$

(ii) $2x-1 > 5$

$$2x-1+1 > 5+1 \quad (\text{Adding } 1 \text{ to both sides})$$

$$2x > 6$$

$$x > 3 \quad (\text{Dividing both sides by } 2)$$

(iii) $6-x > 4$

$$6-x-6 > 4-6 \quad (\text{Subtracting } 6 \text{ from both sides})$$

$$-x > -2$$

$$x < 2 \quad (\text{Multiplying both sides by } -1; \text{ also change } > \text{ into } <)$$

How to include the points in the solution of an inequality?

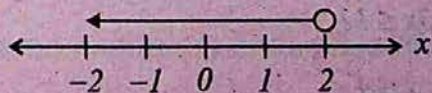

Fig (i)

It is convenient to represent the solution of an inequality, for example, $x < 2$ by using the number line as shown in fig (i). The small empty circle shows that the value '2' is not included as a possible answer where as any value to the left of 2 is included.

EXAMPLE-2

Solve the inequality: $\frac{1}{3}x > \frac{1}{4}(x-1)$

SOLUTION: $\frac{1}{3}x > \frac{1}{4}(x-1)$

$$12 \times \frac{1}{3}x > 12 \times \frac{1}{4}(x-1)$$

$$4x > 3(x-1)$$

$$4x > 3x-3$$

$$4x-3x > -3$$

$$x > -3$$

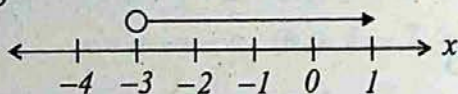

Fig (ii)

The solution is shown by the number line in fig (ii).

EXAMPLE-3

Solve the inequality: $x-7 \leq 5-2x$

SOLUTION: $x-7 \leq 5-2x$

$$x+2x-7 \leq 5$$

$$3x \leq 5+7$$

$$3x \leq 12$$

$$x \leq 4$$

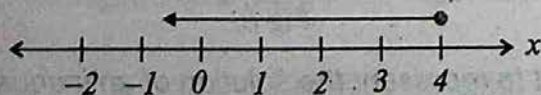

Fig (iii)

The filled circle shows that the point '4' is also included in the solution.

EXAMPLE-4

Solve and graph $\frac{4x-3}{3} + 8 > 6 + \frac{3x}{2}$

SOLUTION: $\frac{4x-3}{3} + 8 > 6 + \frac{3x}{2}$

$$6 \times \frac{4x-3}{3} + 6 \times 8 > 6 \times 6 + 6 \times \frac{3x}{2}$$

$$8x - 6 + 48 > 36 + 9x$$

$$8x + 42 > 36 + 9x$$

$$8x - 9x + 42 > 36$$

$$-x > 36 - 42$$

$$-x > -6$$

$$x < 6$$

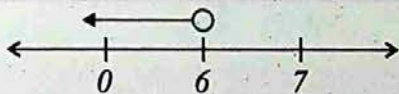

Fig (iv)

The solution is shown by the number line in fig (iv)

Remember that:

Most inequalities are written in algebra. Inequalities are solved in a very similar way to equations. This means we can:

- Add the same number to both sides of an inequality.
- Subtract the same number from both sides of an inequality.
- Multiply or divide both sides of an inequality by any positive number.

EXERCISE - 4.2

Solve:

1. $|x| = 9$

3. $|x+1| = 5$

5. $|3x+4| = 9$

7. $3(x+5) > 2(x+2)+8$

9. $\frac{x-2}{4} + \frac{2}{3} < \frac{x-4}{6}$

11. $\frac{x+1}{2} - \frac{x+3}{3} > \frac{x+1}{4} + 1$

13. $\frac{1}{2}x \geq 1 + \frac{1}{3}x$

15. $\frac{4}{3}(2x+3) \geq 10 - \frac{4x}{3}$

2. $|x-3| = 4$

4. $|2x-3| = 5$

6. $3(x-2) < 2x+1$

8. $\frac{1}{2}(2-x) > \frac{1}{4}(3-x) + \frac{1}{2}$

10. $\frac{3x+4}{5} - \frac{x+1}{3} > 1 - \frac{x+5}{3}$

12. $\frac{x+3}{4} - \frac{x+2}{5} < 1 + \frac{x+5}{6}$

14. $\frac{1}{4}(2x+3) \leq (7-4x)$

16. $\frac{x-2}{4} - \frac{x-5}{6} \geq \frac{1}{3}$

Review Exercise-4

I- Encircle the Correct Answer.

1. An equation that can be written in the form $ax + b = 0, a \neq 0$, where a and b are constants and x is variable is called:

(a) linear equation

(b) inequality

(c) solution

(d) constant

2. Any value of the variable which makes the equation a true statement is called the:

(a) equation

(b) inequality

(c) solution

(d) variable

3. For each number 'x' the absolute value of x is denoted by:

- (a) x (b) $-x$
(c) $|x|$ (d) 0

4. The symbol \geq stands for:

- (a) *greater than* (b) *greater than and equal to*
(c) *less than or equal to* (d) *equal to*

5. The symbol \leq stands for:

- (a) *less than* (b) *greater than and equal to*
(c) *less than or equal to* (d) *equal to*

6. Solution of $|x - 3| = 5$ is:

- (a) $\{8, -2\}$ (b) $\{-8, -2\}$
(c) $\{8, 2\}$ (d) $\{-8, 2\}$

7. Solution of $|x| = 3$ is:

- (a) 3 (b) -3
(c) ± 3 (d) 0

8. Solution of $|x - 1| = 4$ is:

- (a) $\{5, -3\}$ (b) $\{-5, -3\}$
(c) $\{-5, 3\}$ (d) $\{5, 3\}$

I- Fill in the blanks with '>', '=' or '<' to make each of the statement correct.

1. If $15 > 10$ and $10 > p$, then 15 _____ p .

2. If $-3 > x$ and $x > y$, then -3 _____ y .

3. If $a < 60$ and $60 < b$, then a _____ b .

4. If $x + 1 = y$, then x _____ y .

5. If $m - 2 = n$, then m _____ n .

6. If $x > y$, then $4x$ _____ $4y$.

7. If $x > y$, then $\frac{x}{10}$ _____ $\frac{y}{10}$.

8. If $x > y$, then $(-2)x$ _____ $(-2)y$.

$$\frac{y}{-3} = \frac{y}{-3}$$

< 0 , then p _____ 0 .

$-3)u$ _____ 0 .

_____ 0 .

SUMMARY

Linear Equation: An equation that can be written in the form $ax + b = 0$, $a \neq 0$ where a and b are constants and x is a variable, is called a linear equation in one variable.

Solution of a Linear equation : Any value of the variable, which makes the equation a true statement, is called the solution of a linear equation.

Absolute Value: For each real number 'x' the absolute value of x, denoted by $|x|$, is defined by:

$$|x| = \begin{cases} x, & \text{if } x > 0 \\ 0, & \text{if } x = 0 \\ -x, & \text{if } x < 0 \end{cases}$$

Linear Inequalities: Two algebraic expressions joined by an inequality symbol such as $>$, $<$, \leq , \geq is called an inequality.

Trichotomy Property: If $x, y \in R$ then either $x > y$ or $x = y$ or $x < y$.

Transitive Property: If $x, y, z \in R$, then $x > y$ and $y > z \Rightarrow x > z$.

Additive Property: $\forall a, b, c \in R$. If $a > b$, then $a + c > b + c$
and $a - c > b - c$.

Multiplicative Property: $\forall a, b, c \in R$. Let $a > b$. Then $ac > bc$ if $c > 0$
and $ac < bc$ if $c < 0$.

UNIT

5

QUADRATIC EQUATIONS

- ▶ Quadratic Equation
- ▶ Solution of Quadratic Equation
- ▶ Quadratic Formula

After completion of this unit, the students will be able to:

- ▶ define quadratic equation.
- ▶ solve a quadratic equation in one variable by
 - Factorization.
 - Completing Square.
- ▶ use method of completing square to derive quadratic formula.
- ▶ use quadratic formula to solve quadratic equations.
- ▶ solve simple real life problems.

5.1 QUADRATIC EQUATIONS

A quadratic equation in one variable is an equation that can be written in the form:

$$ax^2 + bx + c = 0, \quad a \neq 0,$$

where x is a variable and a, b and c are real numbers. We refer to this form as the **standard form** of the quadratic equation.

A quadratic equation is also a polynomial equation in which the highest power of the unknown variable is two.

5.2 SOLUTION OF A QUADRATIC EQUATION

We can solve a quadratic equation by the following two methods:

- (i) Factorization (ii) Completing the Square (iii) The Quadratic Formula

5.2.1 Solution of a Quadratic Equation by Factorization

The general form of a quadratic equation is $ax^2 + bx + c = 0, a \neq 0$. We can solve this equation algebraically to find x by using Null Factor Law.

If $a \times b = 0$ then $a = 0$ or $b = 0$ (or both a and b equal zero).

The Null Factor Law works only for expressions in factor form.

EXAMPLE-1 Solve $x^2 + 4x - 77 = 0$

SOLUTION: $x^2 + 4x - 77 = 0$

$$(x-7)(x+11) = 0$$

$$x-7 = 0 \quad \text{or} \quad x+11 = 0$$

Write the equation and check that the right hand side equals zero. The left hand side is factorized, so use the Null Factor Law to find two liner equations.

Equations that are not in factor form will need to be factorized first before the Null Factor Law can be applied.

Remember that the right hand side of the equation must be zero.

"A second degree polynomial $ax^2 + bx + c$ with integral coefficients has linear factors if and only if " ac " has integral factors whose sum is b ."

EXAMPLE-2

Solve $6x^2 - 19x - 7 = 0$ using factorization.

SOLUTION:

Compare with standard form

$$ax^2 + bx + c = 0, \quad a = 6, \quad b = -19, \quad c = -7$$

$$ac = 6(-7) = -42$$

$$-42 = (-21)2 \quad \text{and} \quad -21 + 2 = -19 = b$$

$$\text{Thus } 6x^2 - 19x - 7 = 0$$

$$6x^2 - 21x + 2x - 7 = 0$$

$$3x(2x - 7) + 1(2x - 7) = 0$$

$$(2x - 7)(3x + 1) = 0$$

$$\text{either } 2x - 7 = 0 \quad \text{or} \quad 3x + 1 = 0$$

$$x = \frac{7}{2} \quad \text{or} \quad x = -\frac{1}{3}$$

$$\text{Solution set} = \left\{ -\frac{1}{3}, \frac{7}{2} \right\}$$

EXAMPLE-3

Solve $2x^2 = 3x$

SOLUTION:

$$2x^2 = 3x$$

$$2x^2 - 3x = 0$$

$$x(2x - 3) = 0$$

$$\text{either } x = 0 \quad \text{or} \quad 2x - 3 = 0$$

$$x = \frac{3}{2}$$

$$\text{Solution set} = \left\{ 0, \frac{3}{2} \right\}$$

Note: $x = 0, \frac{3}{2}$ are also called roots of the quadratic equation of $2x^2 = 3x$.

EXAMPLE-4

If $x = 3$ is a solution of the equation $x^2 + kx + 15 = 0$. Find the value of 'k'. Also find the other solution of the equation.

SOLUTION: Substitute $x = 3$ in $x^2 + kx + 15 = 0$

$$3^2 + 3k + 15 = 0$$

$$3k + 24 = 0 \Rightarrow k = -8$$

Now consider $x^2 - 8x + 15 = 0$

$$15 = (-5) \times (-3) \quad \text{and} \quad (-5) + (-3) = -8 = b$$

$$x^2 - 5x - 3x + 15 = 0$$

$$x(x-5) - 3(x-5) = 0$$

$$(x-3)(x-5) = 0$$

$$x-3 = 0 \quad \text{or} \quad x-5 = 0$$

$$x = 3 \quad \text{or} \quad x = 5$$

$$\text{Solution set} = \{3, 5\}$$

5.2.2 Solution of a Quadratic Equation by Completing the Square Method

The method of completing the square is based on the process of transforming the standard quadratic equation into the form

$$ax^2 + bx + c = 0 \quad \text{_____ (1)}$$

$$(x+a)^2 = b \quad \text{_____ (2)}, \text{ where } a \text{ and } b \text{ are constants.}$$

Equation (2) can easily be solved by completing the square method. But how do we transform equation (1) into the form of equation (2)?

To complete the square of a quadratic equation of the form $x^2 + bx$, add the square of one-half of the coefficient of x that is $\left(\frac{b}{2}\right)^2$

It is important to note that the rule stated above applies only to quadratic forms where the coefficients of the second degree term is 1.

Important formulas used in completing the square are:

$$(i) \quad (x+m)^2 = x^2 + 2mx + m^2$$

$$(ii) \quad (x-m)^2 = x^2 - 2mx + m^2$$

EXAMPLE-1

Solve $x^2 + 6x - 2 = 0$ by completing the square method.

SOLUTION: $x^2 + 6x - 2 = 0$

$$x^2 + 6x - 2 + 2 = 2$$

← Adding 2 to both sides

$$x^2 + 6x = 2$$

$$x^2 + 6x + (3)^2 = 2 + 3^2$$

← To complete the square of the left side, add the square of one half of the coefficient of x to each side of the equation.

$$(x+3)^2 = 11$$

$$x+3 = \pm\sqrt{11}$$

$$x = -3 \pm \sqrt{11}$$

$$\text{Solution set} = \{-3 + \sqrt{11}, -3 - \sqrt{11}\}$$

EXAMPLE-2

Solve $(x-3)^2 = 4$

SOLUTION: $(x-3)^2 = 4$

$$x^2 - 6x + 9 = 4$$

$$x^2 - 6x = -5$$

$$x^2 - 6x + (3)^2 = -5 + 9$$

$$(x-3)^2 = 4$$

$$x - 3 = \pm 2$$

either $x = 5$

or $x = 1$

$$\text{Solution set} = \{1, 5\}$$

EXAMPLE-3

Solve $3(x-2)^2 = x(x-2)$ by completing the square method.

SOLUTION: $3(x^2 - 4x + 4) = x^2 - 2x$

$$3x^2 - 12x + 12 = x^2 - 2x$$

$$3x^2 - x^2 - 12x + 2x = -12$$

$$2x^2 - 10x = -12$$

$$x^2 - 5x = -6$$

$$x^2 - 5x + \left(\frac{5}{2}\right)^2 = -6 + \left(\frac{5}{2}\right)^2$$

$$\left(x - \frac{5}{2}\right)^2 = -6 + \frac{25}{4} = \left(x - \frac{5}{2}\right)^2 = \frac{1}{4}$$

$$x^2 - \frac{5}{2} = \pm \frac{1}{2}$$

$$x = \frac{5}{2} \pm \frac{1}{2}$$

either $x = \frac{5}{2} + \frac{1}{2} = \frac{6}{2} = 3$

or $x = \frac{5}{2} - \frac{1}{2} = \frac{4}{2} = 2$

Solution set = $\{2, 3\}$

EXAMPLE-4

Solve $10x^2 - 12x = 15$ by completing the square method.

SOLUTION: $10x^2 - 12x = 15$

$$x^2 - \frac{12}{10}x = \frac{15}{10}$$

← Dividing by '10'

$$x^2 - \frac{6}{5}x = \frac{3}{2} \Rightarrow x^2 - \frac{6}{5}x + \left(\frac{3}{5}\right)^2 = \left(\frac{3}{5}\right)^2 + \frac{3}{2}$$

← Adding $\left(\frac{3}{5}\right)^2$ on both sides

$$\left(x - \frac{3}{5}\right)^2 = \frac{9}{25} + \frac{3}{2} = \left(x - \frac{3}{5}\right)^2 = \frac{18+75}{50} \Rightarrow \left(x - \frac{3}{5}\right)^2 = \frac{93}{50}$$

$$x - \frac{3}{5} = \pm \sqrt{\frac{93}{50}} \quad \text{or} \quad x = \frac{3}{5} \pm \frac{\sqrt{93}}{5\sqrt{2}}$$

$$x = \frac{3\sqrt{2} \pm \sqrt{93}}{5\sqrt{2}} \Rightarrow x = \frac{3\sqrt{2} + \sqrt{93}}{5\sqrt{2}} \quad \text{or} \quad x = \frac{3\sqrt{2} - \sqrt{93}}{5\sqrt{2}}$$

$$\text{Solution set} = \left\{ \frac{3\sqrt{2} + \sqrt{93}}{5\sqrt{2}}, \frac{3\sqrt{2} - \sqrt{93}}{5\sqrt{2}} \right\}$$

EXAMPLE-5 Solve $\frac{1}{x} + \frac{1}{x+8} = \frac{1}{3}$ by using factorisation.

SOLUTION: $\frac{1}{x} + \frac{1}{x+8} = \frac{1}{3}$

$$\frac{x+8+x}{x(x+8)} = \frac{1}{3}$$

$$\frac{2x+8}{x^2+8x} = \frac{1}{3}$$

$$x^2 + 8x = 6x + 24$$

$$x^2 + 2x - 24 = 0$$

$$(x+6)(x-4) = 0$$

$$\text{either } x+6 = 0 \quad \text{or} \quad x-4 = 0$$

$$x = -6 \quad \text{or} \quad x = 4$$

$$\text{Solution set} = \{4, -6\}$$

EXAMPLE-6 Solve $2x+4 = \frac{7}{x}-1$

SOLUTION: $2x+4 = \frac{7}{x}-1$

$$x(2x+4) = x\left(\frac{7}{x}-1\right)$$

← Multiplying both sides by 'x'

$$2x^2 + 4x = 7 - x$$

$$2x^2 + 5x - 7 = 0$$

$$(2x+7)(x-1) = 0 \leftarrow$$

$$\text{either } 2x+7 = 0 \Rightarrow x = \frac{-7}{2}$$

$$\text{or } x-1 = 0 \Rightarrow x = 1$$

$$\text{Solution set.} = \left\{ \frac{-7}{2}, 1 \right\}$$

$$a \times c = 2 \times (-7) = -14$$

$2x$	7	$7x$
$\downarrow x$	-1	$-2x$
$2x^2 - 7$		$5x$
$(2x+7)(x-1)$		

EXERCISE - 5.1

I- Solve by Using Factorization Method:

$$1. x^2 - 4x - 12 = 0$$

$$2. x^2 - 6x + 5 = 0$$

$$3. x^2 = 8 - 7x$$

$$4. 5x = x^2 + 6$$

$$5. 3x^2 - 10x + 8 = 0$$

$$6. 2x^2 + 15x - 8 = 0$$

$$7. \frac{x}{4}(x+1) = 3$$

$$8. 3x^2 - 8x - 3 = 0$$

$$9. 2x = \frac{2}{x} + 3$$

$$10. 5x^2 - 6x - 8 = 0$$

$$11. (2x+3)(x-2) = 0$$

$$12. (2x+1)(5x-4) = 0$$

$$13. 4x(3x-1) - 2 = (2x-1)(5x+1)$$

II- Solve by Completing the Square Method:

$$14. x^2 - 10x - 3 = 0$$

$$15. x^2 - 6x - 3 = 0$$

$$16. x^2 + x - 1 = 0$$

$$17. x^2 + 6x - 3 = 0$$

$$18. 2x^2 - 4x + 1 = 0$$

$$19. 2x^2 - 6x + 3 = 0$$

$$20. 3x^2 + 5x - 4 = 0$$

$$21. x^2 + mx + n = 0$$

$$22. 11x^2 = 6x + 21$$

$$23. 2x^2 + 8x - 26 = 0$$

$$24. 5x^2 - 20x - 28 = 0$$

$$25. x^2 - 11x - 26 = 0$$

5.3 THE QUADRATIC FORMULA

Quadratic formula is one of the techniques to solve a quadratic equation. Usually this formula is used when the factorization is not possible or seems to be too difficult.

5.3.1 Derivation of Quadratic Formula

The general form of a quadratic equation is

$$ax^2 + bx + c = 0, \quad a \neq 0$$

where a, b, c are real numbers.

Now, we use the method of completing the square to derive a formula for the solution of all quadratic equations,

$$ax^2 + bx + c = 0, \quad a \neq 0$$

To make the leading coefficient that is of x^2 as 1, divide by a .

$$x^2 + \frac{b}{a}x + \frac{c}{a} = 0 \quad \text{or} \quad x^2 + \frac{b}{a}x = -\frac{c}{a}$$

Add the square of one-half of the coefficient of x , which is $\left(\frac{b}{2a}\right)^2$, to each side to complete the square of the left side.

$$x^2 + \frac{b}{a}x + \left(\frac{b}{2a}\right)^2 = \frac{b^2}{4a^2} - \frac{c}{a} \Rightarrow \left(x + \frac{b}{2a}\right)^2 = \frac{b^2 - 4ac}{4a^2}$$

$$x + \frac{b}{2a} = \pm \frac{\sqrt{b^2 - 4ac}}{2a}$$

$$x = -\frac{b}{2a} \pm \frac{\sqrt{b^2 - 4ac}}{2a}$$

$$x = \frac{-b \pm \sqrt{b^2 - 4ac}}{2a}$$

Techniques to solve a Quadratic Equation

- (i) Factorization
- (ii) Completing the Square Method.
- (iii) Use of Quadratic Formula

The last equation is called the quadratic formula.

EXAMPLE-1

Solve $2x + \frac{3}{2} = x^2$ by using the quadratic formula.

SOLUTION:

$$2x + \frac{3}{2} = x^2$$

$$4x + 3 = 2x^2$$

Dissolve the fractions by multiplying 2 on both sides and write the equation in standard form

$$2x^2 - 4x - 3 = 0$$

Here $a = 2$

$b = -4$

$c = -3$

We have ,
$$x = \frac{-b \pm \sqrt{b^2 - 4ac}}{2a}$$

$$x = \frac{-(-4) \pm \sqrt{(-4)^2 - 4(2)(-3)}}{2(2)}$$

$$= \frac{4 \pm \sqrt{16 + 24}}{4} = \frac{4 \pm \sqrt{40}}{4}$$

$$= \frac{4 \pm 2\sqrt{10}}{4}$$

$$x = \frac{2 \pm \sqrt{10}}{2}$$

Solution set
$$= \left\{ \frac{2 + \sqrt{10}}{2}, \frac{2 - \sqrt{10}}{2} \right\}$$

EXAMPLE-2

Solve $4x^2 + 3x - 2 = 0$ by using the quadratic formula.

SOLUTION: $4x^2 + 3x - 2 = 0$

Here $a = 4, b = 3, c = -2$

We have $x = \frac{-b \pm \sqrt{b^2 - 4ac}}{2a}$

$$x = \frac{-3 \pm \sqrt{3^2 - 4(4)(-2)}}{2(4)}$$

$$= \frac{-3 \pm \sqrt{9 + 32}}{8}$$

$$= \frac{-3 \pm \sqrt{41}}{8}$$

Solution set $= \left\{ \frac{-3 + \sqrt{41}}{8}, \frac{-3 - \sqrt{41}}{8} \right\}$

EXAMPLE-3

Solve $9x^2 - 42x + 49 = 0$ by using the quadratic formula.

SOLUTION: $9x^2 - 42x + 49 = 0$

Here $a = 9, b = -42, c = 49$

We have $x = \frac{-b \pm \sqrt{b^2 - 4ac}}{2a}$

$$x = \frac{-(-42) \pm \sqrt{(-42)^2 - 4(9)(49)}}{2(9)}$$

$$x = \frac{42 \pm \sqrt{1764 - 1764}}{18} \Rightarrow x = \frac{42}{18} = \frac{7}{3}$$

Solution set $= \left\{ \frac{7}{3} \right\}$

EXAMPLE-4

Solve $(x+5)^2 + (2x-1)^2 - 67 = (x+5)(2x-1)$
by using quadratic formula.

SOLUTION: $(x+5)^2 + (2x-1)^2 - 67 = (x+5)(2x-1)$

$$x^2 + 10x + 25 + 4x^2 - 4x + 1 - 67 = 2x^2 + 10x - x - 5$$

$$5x^2 + 6x - 41 = 2x^2 + 9x - 5$$

$$3x^2 - 3x - 36 = 0$$

$$x^2 - x - 12 = 0$$

← Divide by '3'

Here $a = 1$, $b = -1$, $c = -12$

We have,
$$x = \frac{-b \pm \sqrt{b^2 - 4ac}}{2a}$$

Therefore
$$x = \frac{-(-1) \pm \sqrt{(-1)^2 - 4(1)(-12)}}{2(1)}$$

$$= \frac{1 \pm \sqrt{1+48}}{2}$$

$$= \frac{1 \pm \sqrt{49}}{2}$$

$$x = \frac{1 \pm 7}{2}$$

either $x = \frac{1+7}{2}$ or $x = \frac{1-7}{2}$

$$x = 4 \text{ or } x = -3$$

Solution set = $\{4, -3\}$

EXAMPLE-5

Solve $\frac{x-5}{2x} = \frac{x-4}{3}$ by using quadratic formula.

SOLUTION:
$$\frac{x-5}{2x} = \frac{x-4}{3}$$

$$3(x-5) = 2x(x-4)$$

$$3x-15 = 2x^2 - 8x$$

$$2x^2 - 11x + 15 = 0$$

Here $a = 2$, $b = -11$, $c = 15$

We have
$$x = \frac{-b \pm \sqrt{b^2 - 4ac}}{2a}$$

$$= \frac{-(-11) \pm \sqrt{(-11)^2 - 4(2)(15)}}{2(2)}$$

$$= \frac{11 \pm \sqrt{121 - 120}}{4}$$

$$x = \frac{11 \pm \sqrt{1}}{4} = \frac{11 \pm 1}{4}$$

$$x = \frac{11+1}{4} \quad \text{or} \quad x = \frac{11-1}{4}$$

$$x = \frac{12}{4} \quad \text{or} \quad x = \frac{10}{4}$$

$$x = 3 \quad \text{or} \quad x = \frac{5}{2}$$

Solution set $= \left\{ 3, \frac{5}{2} \right\}$

EXERCISE - 5.2

Solve Using quadratic formula:

1. $x^2 - 5x + 6 = 0$

2. $(3 - 4x) = (4x - 3)^2$

3. $3x^2 + x - 2 = 0$

4. $10x^2 - 5x = 15$

5. $(x - 1)(x + 3) - 12 = 0$

6. $x(2x + 7) - 3(2x + 7) = 0$

7. $\frac{x+1}{x+4} = \frac{2x-1}{x+6}$, where $x \neq -4, -6$

8. $\frac{x}{6} + \frac{6}{x} = \frac{4}{x} + \frac{x}{4}$, where $x \neq 0$

9. $\frac{x+4}{x-4} + \frac{x-4}{x+4} = \frac{10}{3}$ where $x \neq -4$

10. $\frac{1}{x-1} + \frac{1}{x-2} = \frac{2}{x-3}$ where $x \neq 1, 2, 3$

11. $(x+4)(x-1) + (x+5)(x+2) = 6$

12. $(2x+4)^2 - (4x-6)^2 = 0$

5.3.3 Problems Involving Quadratic Equations

EXAMPLE-1

Find two consecutive positive odd numbers such that the sum of their squares is equal to 130.

SOLUTION: Let one odd number be x and the other number be $(x + 2)$

$$x^2 + (x + 2)^2 = 130$$

$$x^2 + x^2 + 4x + 4 = 130$$

$$2x^2 + 4x - 126 = 0$$

$$x^2 + 2x - 63 = 0$$

← Dividing by '2'

$$x^2 + 9x - 7x - 63 = 0$$

$$x(x + 9) - 7(x + 9) = 0$$

$$(x + 9)(x - 7) = 0$$

$$x + 9 = 0 \text{ or } x - 7 = 0$$

$$x = -9 \text{ or } x = 7$$

$x = -9$ is not a solution, because it is a negative number.

When $x = 7$

$$x + 2 = 7 + 2 = 9$$

\therefore The two consecutive positive odd numbers are 7 and 9.

The area of the square is $10m^2$

The side of the square is $x m$.

Write down an equation that tells us that the area is $10m^2$

Solve this equation for x .

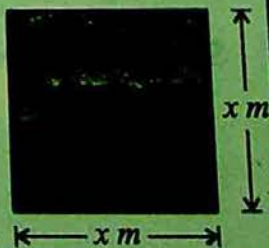

EXAMPLE-2

The perimeter of a rectangle is 22cm and its area is 24cm. Calculate the length and breadth of the rectangle.

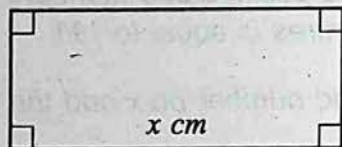

SOLUTION: Let the length of the rectangle = x cm.

$$\text{Perimeter of rectangle} = 2(\text{length} + \text{breadth})$$

$$\therefore 22 = 2(x + \text{breadth})$$

$$\text{The breadth of the rectangle} = \frac{22 - 2x}{2}$$

$$= (11 - x) \text{ cm}$$

$$\text{Area of the rectangle} = x(11 - x)$$

$$24 = 11x - x^2$$

$$x^2 - 11x + 24 = 0$$

$$(x - 3)(x - 8) = 0$$

$$\text{therefore } x = 3 \quad \text{or} \quad x = 8$$

$$\text{when } x = 3, \text{ breadth} = 11 - 3$$

$$= 8 \text{ cm}$$

$$\text{when } x = 8, \text{ breadth} = 11 - 8$$

$$= 3 \text{ cm}$$

Since we assign the longer side to length,

$$\text{thus length} = 8 \text{ cm}$$

$$\text{breadth} = 3 \text{ cm}$$

EXAMPLE-3

A man is now 5 times as old as his son.
Four years ago, the product of their ages was 52.
Find their present ages.

SOLUTION: Let the boy be x years old now.

Then his father is $5x$ years old.

4 years ago, their ages were $(x - 4)$ and $(5x - 4)$, respectively.

By the given condition $(x - 4)(5x - 4) = 52$

$$5x^2 - 24x + 16 = 52$$

$$5x^2 - 24x - 36 = 0$$

$$5x^2 - 30x + 6x - 36 = 0$$

$$5x(x - 6) + 6(x - 6) = 0$$

$$(5x + 6)(x - 6) = 0$$

$$\text{either } 5x + 6 = 0 \text{ or } x - 6 = 0$$

$$\Rightarrow x = \frac{-6}{5}, \quad \Rightarrow x = 6$$

Since the boy cannot be $-\frac{6}{5}$ years old. Thus $x = 6$

Son's present age = 6 years

Father's present age = 30 years

EXAMPLE-4

Find two consecutive positive numbers such that the sum of their squares is equal to 113.

SOLUTION: Let $x, x + 1$ be two consecutive positive numbers.

By given condition $x^2 + (x + 1)^2 = 113$

$$x^2 + x^2 + 2x + 1 = 113$$

$$2x^2 + 2x - 112 = 0$$

← Divide by '2'

$$x^2 + x - 56 = 0$$

$$(x + 8)(x - 7) = 0$$

$$x + 8 = 0 \text{ or } x - 7 = 0$$

$$x = -8 \text{ or } x = 7$$

$$x + 1 = 7 + 1 = 8$$

\therefore Required numbers are 7 and 8

EXERCISE - 5.3

1. Find two consecutive positive odd numbers such that the sum of their squares is 74.
2. Find two consecutive positive even numbers such that the sum of their squares is 164.
3. The difference of two numbers is 9 and the product of the numbers is 162. Find the numbers.
4. The base and height of a triangle are $(x + 3)$ cm and $(2x - 5)$ cm respectively. If the area of the triangle is 20cm^2 , find x .
5. The perimeter and area of a rectangle are 22cm and 30cm^2 respectively. Find the length and breadth of the rectangle.
6. The product of two consecutive positive numbers is 156. Find the numbers.
7. Find two consecutive positive odd numbers given that the difference between their reciprocals is $\frac{2}{63}$.
8. The sum of the two positive numbers is 12 and the sum of whose squares is 80. Find the numbers.

Review Exercise-5

I- Encircle the Correct Answer.

1. A quadratic equation has a degree:

- (a) 2 (b) 1 (c) zero (d) 3

2. A linear equation in one variable is of degree:

- (a) 2 (b) 1 (c) zero (d) 3

3. Factorization of $2x^2 = 3x$ is:

- (a) 0 (b) $x(2x - 3)$
(c) $2x^2 - 3x$ (d) $3x - 2x^2$

4. Solution set of $(x - 2)^2 = 4$ is:

- (a) $\{0, 4\}$ (b) $\{-6, 2\}$
(c) $\{-6 - 2\}$ (d) $\{2, 6\}$

5. The number of techniques to solve a quadratic equation is:

- (a) 1 (b) 2 (c) 3 (d) 4

6. Solution of $x^2 - 5x + 6 = 0$ is:

- (a) $\{3\}$ (b) $\{2\}$ (c) $\{2, 3\}$ (d) $\{-2, -3\}$

7. Solution of $x^2 - 9 = 0$ is:

- (a) $\{9\}$ (b) $\{\pm 9\}$ (c) $\{\pm 3\}$ (d) $\{3\}$

8. Factorization of $x^4 - 16$ is:

- (a) $(x - 2)(x + 2)$ (b) $(x - 2)(x + 2)(x - 4)$
(c) $(x - 2)(x + 2)(x^2 + 4)$ (d) $(x - 2)^2$

9. Solution of $x^2 = 1$ is:

- (a) $\{1\}$ (b) $\{\pm 1\}$ (c) $\{\pm i\}$ (d) $\{-1\}$

10. $x^2 + 2x + 1 = 0$ has the solution:

- (a) $\{-1, -1\}$ (b) $\{-1\}$ (c) $\{0\}$ (d) does not exist

77- Fill in the blanks.

An equation of degree 2 in one variable is called a _____ equation.

$\frac{b \pm \sqrt{b^2 - 4ac}}{2a}$ is called a _____.

of $2x^2 - 3x$ is: _____.

$(x-1)^2 = 4$ is: _____.

_____ techniques to solve a quadratic equation

_____ completing the square method cannot be
_____ is used to solve a quadratic equation.

SUMMARY

Quadratic Equation: A quadratic equation in one variable is an equation that can be written in the form $ax^2 + bx + c = 0$, where $a \neq 0$. Here 'x' is a variable, whereas a , b and c are real numbers.

Solution of quadratic Equation: We can solve a quadratic equation by
(i) factorization (ii) completing the square method.

Quadratic Formula: $x = \frac{-b \pm \sqrt{b^2 - 4ac}}{2a}$

MATRICES AND DETERMINANTS

- ▶ Introduction to Matrices
- ▶ Types of Matrices
- ▶ Addition and Subtraction of Matrices
- ▶ Multiplication of Matrices
- ▶ Multiplicative Inverse of a Matrix
- ▶ Solution of Simultaneous Linear Equations

After completion of this unit, the students will be able to:

- ▶ define
 - A matrix with real entries and relate its rectangular layout (formation) with real life.
 - Rows and columns of a matrix. • The order of matrix. • Equality of two matrices.
- ▶ define and identify row matrix, column matrix, rectangular matrix, square matrix, zero/null matrix, identity matrix, scalar matrix, diagonal matrix, transpose of a matrix, symmetric and skew-symmetric matrices.
- ▶ know whether the given matrices are conformable for addition/subtraction.
- ▶ add and subtract matrices.
- ▶ multiply a matrix by a real number.
- ▶ verify commutative and associative laws under addition.
- ▶ define additive identity of a matrix.
- ▶ find additive inverse of a matrix.
- ▶ know whether the given matrices are conformable for multiplication.
- ▶ multiplication of two (or three) matrices.
- ▶ verify associative law under multiplication.
- ▶ verify distributive laws.
- ▶ show with an example that commutative law under multiplication does not hold in general (i.e., $AB \neq BA$).
- ▶ define multiplicative identity of a matrix.
- ▶ verify the result $(AB)^t = B^t A^t$.
- ▶ define the determinant of a square matrix.
- ▶ evaluate determinant of a matrix.
- ▶ define singular and non-singular matrices.
- ▶ define adjoint of a matrix.
- ▶ find multiplicative inverse of a non-singular matrix A and verify that $AA^{-1} = I = A^{-1}A$, where I is the identity matrix.
- ▶ use adjoint method to calculate inverse of a non-singular matrix.
- ▶ verify the result $(AB)^{-1} = B^{-1}A^{-1}$.
- ▶ solve a system of two linear equations and related real life problems in two unknown using.
 - Matrix inversion method, • Cramer's rule.

6.1 INTRODUCTION

In this chapter we will introduce a new mathematical form, called a matrix, that will enable us to represent a number of different quantities as a single unit.

The idea of matrices was introduced by a famous mathematician Arther Cayley in 1857. Matrices are widely used in both the physical and the social sciences.

A matrix is a square or a rectangular array of numbers written within square brackets or parentheses in a definite order, in rows and columns.

Generally, the matrices (*plural of the matrix*) are denoted by capital letters A, B, C, \dots etc. while the elements of a matrix are denoted by small letters a, b, c, \dots and numbers $1, 2, 3, \dots$. For example:

$$A = \begin{bmatrix} 1 & 2 \\ 3 & 5 \end{bmatrix}, \quad B = \begin{bmatrix} 7 \\ 2 \end{bmatrix}, \quad C = [4 \ 5], \quad D = \begin{bmatrix} a & b \\ c & d \end{bmatrix}$$

Look at another example:

A company that manufactures shirts makes a standard model and a competition model. The labour (*in hours*) required for each model is conveniently represented by the 2×3 matrix.

$$M = \begin{array}{ccc} \begin{array}{c} \text{Fabricating} \\ \text{Finishing} \\ \text{Packaging and} \\ \text{handling} \end{array} & \begin{array}{c} 5 \\ 1 \\ 0.2 \end{array} & \begin{array}{c} 7 \\ 2 \\ 0.2 \end{array} \\ M = \begin{bmatrix} 5 & 7 \\ 1 & 2 \\ 0.2 & 0.2 \end{bmatrix} & \text{Standard Shirts} & \end{array}$$

The weekly production can be represented by the row matrix

$$\begin{array}{cc} \text{Standard} & \text{Competition} \\ \text{Shirts} & \text{Shirts} \\ [100 & 10] \end{array}$$

Each matrix consists of horizontally and vertically arranged elements.

$$A = \begin{bmatrix} 1 \\ 3 \end{bmatrix} \quad \begin{bmatrix} 2 \\ 5 \end{bmatrix}$$

Vertically arranged elements.

$$A = \begin{bmatrix} 1 & 2 \\ 3 & 5 \end{bmatrix}$$

Horizontally arranged elements

Rows: Horizontally arranged elements are said to form rows.

Columns: Vertically arranged elements are said to form columns.

The number of rows and columns in matrices may be equal or different. However, the number of elements in different rows are same and similar is the case in the columns of a matrix that remains the same.

Generally, rows and columns are denoted by R and C respectively. For example:

$$A = \begin{bmatrix} a & b \\ c & d \end{bmatrix}$$

$\begin{matrix} \text{Column 1} & \text{Column 2} \\ \text{or} & \text{or} \\ C_1 & C_2 \\ \downarrow & \downarrow \\ \leftarrow \text{Row 1 or } R_1 & \\ \leftarrow \text{Row 2 or } R_2 & \end{matrix}$

Matrix A has two, rows and two columns whereas a, b, c, d are its elements. The number of rows and the number of columns are denoted by m and n respectively.

In the above example $m = 2$ and $n = 2$

Order of a Matrix:-

If a matrix A has ' m ' number of rows and ' n ' number of columns, then order of the matrix A is $m \times n$ (read as " m -by- n matrix")

EXAMPLE-1 Find the order of $P = [3]$

SOLUTION: Matrix P has only one row and one column.
So order of P is 1×1 matrix.

EXAMPLE-2 Find the order of $Q = [4 \quad 7]$

SOLUTION: Matrix Q has one row and two columns.
So order of Q is 1×2 matrix.

EXAMPLE-3 Find the order of $R = \begin{bmatrix} 3 & 4 \\ 5 & 7 \end{bmatrix}$

SOLUTION: In matrix R , the number of rows is two i.e $m = 2$
and the number of columns is two i.e $n = 2$.
The order of R is 2×2 matrix.

EXAMPLE-4 Find the order of $A = \begin{bmatrix} 3 & 4 & 9 \\ 5 & 7 & 2 \\ 1 & 2 & 5 \end{bmatrix}$

SOLUTION: In matrix A , the number of rows is three i.e $m = 3$
and the number of columns is three, i.e $n = 3$.
The order of A is 3×3 matrix.

Remember that:

- ▶ We denote order of a matrix $m \times n$ instead of m by n .
- ▶ It is important to remember that in the order of a matrix, the number of rows are mentioned first.

Equal Matrices:-

Two matrices A and B are said to be equal if and only if they have the same order and their corresponding elements are equal.

Their equality is denoted by $A = B$.

For example:
$$\begin{bmatrix} w & x \\ y & z \end{bmatrix} = \begin{bmatrix} a & b \\ c & d \end{bmatrix} \Leftrightarrow \begin{cases} w = a \\ x = b \\ y = c \\ z = d \end{cases}$$

EXAMPLE

Which of the following matrices are equal and which of them are not equal ?

$$A = \begin{bmatrix} 1 & 2 \\ 3 & 4 \end{bmatrix}, B = \begin{bmatrix} 3-2 & \frac{4}{2} \\ 3 & 2 \times 2 \end{bmatrix},$$

$$C = \begin{bmatrix} 1 & 3 \\ 4 & 5 \end{bmatrix}, D = \begin{bmatrix} 1 & 3 & 7 \\ 2 & 1 & 3 \\ 4 & 2 & 5 \end{bmatrix}, E = \begin{bmatrix} 1 & \frac{6}{2} & 7 \\ \frac{6}{3} & 1 & 3 \\ 2 \times 2 & 2 & \frac{10}{2} \end{bmatrix},$$

$$F = \begin{bmatrix} 1 & 3 & 7 \\ 2 & 1 & 3 \end{bmatrix}$$

SOLUTION: Matrix B , can be written as

$$B = \begin{bmatrix} 3-2 & \frac{4}{2} \\ 3 & 2 \times 2 \end{bmatrix} = \begin{bmatrix} 1 & 2 \\ 3 & 4 \end{bmatrix} = A$$

(i) Order of A and B is same 2 by 2, and corresponding elements are equal, so $A = B$.

(ii) Order of A , B and C is same 2 by 2, but corresponding elements are not equal, so $A = B \neq C$.

(iii) Matrix E can be written as:
Order of D and E is same, i.e 3 by 3 and corresponding elements are equal,
so $D = E$.

$$E = \begin{bmatrix} 1 & \frac{6}{2} & 7 \\ \frac{6}{3} & 1 & 3 \\ 2 \times 2 & 2 & \frac{10}{2} \end{bmatrix} = \begin{bmatrix} 1 & 3 & 7 \\ 2 & 1 & 3 \\ 4 & 2 & 5 \end{bmatrix} = D$$

(iv) Order of the matrix F is 2 by 3, so $F \neq D$ and $E \neq F$.

EXERCISE - 6.1

With the help of the given matrices answer the questions from 1 to 3.

$$A = \begin{bmatrix} 2 & -2 \\ -5 & 0 \end{bmatrix}, \quad B = \begin{bmatrix} -3 & -2 \\ 0 & 4 \end{bmatrix}, \quad C = \begin{bmatrix} 3 \\ -1 \\ 0 \end{bmatrix},$$

$$D = \begin{bmatrix} -3 & 2 & 0 \\ 0 & 1 & 5 \\ 4 & -2 & 2 \end{bmatrix}, \quad E = [-3 \quad 2 \quad 0], \quad F = \begin{bmatrix} -3 & 4 \\ 0 & 5 \\ 3 & -1 \end{bmatrix}$$

- 1- What are the orders of matrices A, C and F?
- 2- What are the orders of matrices B, D and E?
- 3- What element is in the second row and third column of matrix D?
- 4- Which of the following matrices are equal and which of them are not?

$$A = [4], \quad B = [1 \quad 2], \quad C = \begin{bmatrix} 6 \\ 9 \end{bmatrix}, \quad D = [2+2]$$

$$E = \begin{bmatrix} 3+3 \\ 8+1 \end{bmatrix}, \quad F = \begin{bmatrix} 5 & 4 \\ 5 & 2 \end{bmatrix}, \quad G = \begin{bmatrix} 1 & 3 \\ 6 & 8 \end{bmatrix},$$

$$H = \begin{bmatrix} 1 & 2 & 5 \\ 0 & 3 & 4 \\ 2 & 6 & 3 \end{bmatrix}, \quad I = \begin{bmatrix} 1 & 3 \\ 6 & 7 \end{bmatrix}, \quad J = \begin{bmatrix} 1 & 3 \\ 6 & 16/2 \end{bmatrix},$$

$$K = \begin{bmatrix} 1 & 2 & 3+2 \\ 0 & 3 & 4 \\ 2 & 4+2 & 3 \end{bmatrix}, \quad L = \begin{bmatrix} 1 & 3 & 5 \\ 0 & 3 & 4 \\ 2 & 6 & 3 \end{bmatrix},$$

6.2 TYPES OF MATRICES

(I) Row Matrix:-

A matrix with only one row is called a row matrix.

For example: $A = [1 \ 2]$ is of order 1×2 .

$B = [2 \ 3 \ 4]$ is of order 1×3 .

(II) Column Matrix:-

A matrix with only one column is called a column matrix.

For example: $C = \begin{bmatrix} 1 \\ 3 \end{bmatrix}$ is of order 2×1 .

$D = \begin{bmatrix} 3 \\ 2 \\ 7 \end{bmatrix}$ is of order 3×1 .

(III) Rectangular Matrix:-

If in a matrix, the number of rows and the number of columns are not equal, then the matrix is called a rectangular matrix.

For example: $A = [2 \ 5]$, $B = \begin{bmatrix} 3 \\ 4 \end{bmatrix}$,
 $C = \begin{bmatrix} 1 & 2 & 7 \\ 3 & 4 & 5 \end{bmatrix}$

are rectangular matrices of order 1×2 , 2×1 and 2×3 respectively.

(IV) Square Matrix:-

If a matrix has equal number of rows and columns, it is called a square matrix.

For example: $P = \begin{bmatrix} 2 & 0 \\ -3 & 1 \end{bmatrix}$, $Q = \begin{bmatrix} 1 & 3 & 5 \\ 2 & 4 & 6 \\ 3 & 5 & 7 \end{bmatrix}$

are square matrices of order 2×2 and 3×3 respectively.

(V) Zero or Null Matrix:-

If all the elements in a matrix are zeros, it is called a zero matrix or null matrix. A null matrix is denoted by the letter O .

For example: $O = [0]$ is of order 1×1 .

$$O = [0 \quad 0] \quad \text{is of order } 1 \times 2.$$

$$O = \begin{bmatrix} 0 & 0 \\ 0 & 0 \end{bmatrix} \quad \text{is of order } 2 \times 2.$$

$$O = \begin{bmatrix} 0 & 0 & 0 \\ 0 & 0 & 0 \\ 0 & 0 & 0 \end{bmatrix} \quad \text{is of order } 3 \times 3.$$

(VI) Diagonal Matrix:-

A square matrix in which all the elements except at least the one element in the diagonal are zeros is called a diagonal matrix. Some elements of the diagonal in a matrix may be zero but not all.

For example: $A = \begin{bmatrix} 3 & 0 \\ 0 & 4 \end{bmatrix}$, $B = \begin{bmatrix} 0 & 0 \\ 0 & 3 \end{bmatrix}$, $C = \begin{bmatrix} 1 & 0 & 0 \\ 0 & 2 & 0 \\ 0 & 0 & 3 \end{bmatrix}$

are all diagonal matrices.

(VII) Scalar Matrix:-

A diagonal matrix having equal elements is called a scalar matrix.

For example:

$$A = \begin{bmatrix} 5 & 0 \\ 0 & 5 \end{bmatrix}, B = \begin{bmatrix} \sqrt{2} & 0 \\ 0 & \sqrt{2} \end{bmatrix}, C = \begin{bmatrix} 4 & 0 & 0 \\ 0 & 4 & 0 \\ 0 & 0 & 4 \end{bmatrix} \quad \text{are scalar matrices.}$$

(VIII) Unit Matrix or Identity Matrix:-

A scalar matrix having each element equal to 1 is called a unit or identity matrix. Identity or unit matrix is generally denoted by I .

For example:

$$I = [1] \quad I = \begin{bmatrix} 1 & 0 \\ 0 & 1 \end{bmatrix} \quad I = \begin{bmatrix} 1 & 0 & 0 \\ 0 & 1 & 0 \\ 0 & 0 & 1 \end{bmatrix}$$

are identity matrices of different orders.

(IX) Transpose of a Matrix:-

If A is a matrix of order $(m \times n)$, then a matrix $(n \times m)$ obtained by interchanging the rows and columns of A is called the transpose of A . It is denoted by A' .

For example:

$$A = \begin{bmatrix} a & b \\ c & d \end{bmatrix}, \text{ then } A' = \begin{bmatrix} a & c \\ b & d \end{bmatrix}$$

$$B = \begin{bmatrix} 1 & 2 & 3 \\ 4 & 5 & 6 \\ 7 & 8 & 9 \end{bmatrix}, \text{ then } B' = \begin{bmatrix} 1 & 4 & 7 \\ 2 & 5 & 8 \\ 3 & 6 & 9 \end{bmatrix}$$

If A' and B' are transposes of A and B respectively, and if k is scalar. Then:

$$(a) (A')' = A$$

$$(b) (kA)' = kA'$$

$$(c) (A+B)' = A' + B'$$

$$(d) (AB)' = B'A'$$

(X) Symmetric Matrix:- A square matrix A is called symmetric if $A' = A$

For example: $A = \begin{bmatrix} p & q \\ q & r \end{bmatrix}$ and $A' = \begin{bmatrix} p & q \\ q & r \end{bmatrix}$

Since $A' = A$

A is symmetric matrix.

$$B = \begin{bmatrix} 1 & -2 & 3 \\ -2 & 0 & 4 \\ 3 & 4 & 2 \end{bmatrix} \quad B' = \begin{bmatrix} 1 & -2 & 3 \\ -2 & 0 & 4 \\ 3 & 4 & 2 \end{bmatrix}$$

Since $B' = B$

Matrix B is symmetric.

(XI) Skew-Symmetric Matrix:-

A square matrix A is called skew symmetric (or anti-symmetric) if $A' = -A$.

For example: $A = \begin{bmatrix} 0 & -2 & 3 \\ 2 & 0 & 4 \\ -3 & -4 & 0 \end{bmatrix}$

$$A' = \begin{bmatrix} 0 & 2 & -3 \\ -2 & 0 & -4 \\ 3 & 4 & 0 \end{bmatrix} = - \begin{bmatrix} 0 & -2 & 3 \\ 2 & 0 & 4 \\ -3 & -4 & 0 \end{bmatrix} = -A$$

$A' = -A$ Hence A is skew symmetric.

EXERCISE - 6.2

- 1- Identify row matrices, column matrices, square matrices, and rectangular matrices in the following matrices.

$$A = [3 \ 1 \ 1 \ 1], B = \begin{bmatrix} 5+2 & 4 \\ 2 & 6 \end{bmatrix}, C = \begin{bmatrix} a+x \\ b+y \end{bmatrix}, D = \begin{bmatrix} 2 & 4 \\ 1 & 3 \end{bmatrix},$$

$$E = \begin{bmatrix} x & -2 \\ b & 5 \end{bmatrix}, F = \begin{bmatrix} 1 & 3 & 2 \\ 2 & 4 & 5 \\ 1 & -5 & 0 \end{bmatrix}, G = \begin{bmatrix} 1 & 2 & 4 \\ 5 & 7 & 8 \end{bmatrix}, H = [0]$$

- 2- Identify, diagonal matrices, scalar matrices, identity matrices.

$$A = \begin{bmatrix} 3 & 0 & 0 \\ 0 & 1 & 0 \\ 0 & 0 & 0 \end{bmatrix}, B = \begin{bmatrix} 7 & 0 & 0 \\ 0 & 7 & 0 \\ 0 & 0 & 7 \end{bmatrix}, C = \begin{bmatrix} 0 & 0 & 0 \\ 0 & 0 & 0 \\ 0 & 0 & 4 \end{bmatrix}, D = \begin{bmatrix} 1 & 0 & 0 \\ 0 & 1 & 0 \\ 0 & 0 & 1 \end{bmatrix},$$

$$E = \begin{bmatrix} 5 & 0 \\ 0 & 5 \end{bmatrix}, F = \begin{bmatrix} 8 & 0 \\ 0 & 0 \end{bmatrix}, G = \begin{bmatrix} k & 0 & 0 \\ 0 & k & 0 \\ 0 & 0 & k \end{bmatrix}$$

3- Find transpose of the following matrices.

$$A = \begin{bmatrix} 3 & 4 \\ -1 & 4 \end{bmatrix}, B = \begin{bmatrix} -3 & -2 \\ -1 & 4 \end{bmatrix}, C = \begin{bmatrix} a & -b \\ c & d \end{bmatrix}, D = \begin{bmatrix} l & m & n \\ p & q & r \\ a & b & c \end{bmatrix}$$

4- Identify all row matrices, if:

$$A = [3 \quad 4 \quad 5], B = \begin{bmatrix} -1 & 3 \\ 4 & 6 \end{bmatrix}, C = [e \quad f \quad g],$$

$$D = \begin{bmatrix} 3 & 7 & 5 \\ 4 & 6 & 2 \\ 1 & 9 & 8 \end{bmatrix}, F = \begin{bmatrix} 1 & 4 & 6 \\ 3 & 7 & 3 \end{bmatrix}$$

5- Identify all column matrices, if:

$$A = \begin{bmatrix} 3 \\ 6 \\ 10 \end{bmatrix}, B = \begin{bmatrix} 2 & 3 \\ 6 & 5 \\ 4 & 7 \end{bmatrix}, C = \begin{bmatrix} a \\ b \\ c \end{bmatrix}, D = \begin{bmatrix} 2 & -1 & 3 \\ 4 & 6 & 5 \\ -2 & 3 & 4 \end{bmatrix},$$

$$E = \begin{bmatrix} 5 \\ 7 \\ -4 \end{bmatrix}, F = [9 \quad 7 \quad 1]$$

6- Identify all column matrices, if:

$$A = \begin{bmatrix} 1 & 3 \\ 2 & 2 \end{bmatrix}, B = \begin{bmatrix} 3 & -2 & 4 \\ 1 & 6 & 5 \\ 7 & 3 & 4 \end{bmatrix}, C = \begin{bmatrix} 1 \\ 2 \\ 9 \end{bmatrix}, D = \begin{bmatrix} 7 & 8 \\ 6 & 5 \end{bmatrix},$$

$$E = [3 \quad 5 \quad 7], F = \begin{bmatrix} a & b \\ c & d \end{bmatrix}$$

7- Identify all 3×3 square matrices, if:

$$A = \begin{bmatrix} 2 & -3 & 6 \\ 1 & 5 & 4 \\ 3 & 6 & -3 \end{bmatrix}, B = \begin{bmatrix} 2 \\ 4 \\ 7 \end{bmatrix}, C = [7 \quad 3 \quad 4]$$

6.3 ADDITION AND SUBTRACTION OF MATRICES

Two matrices A and B are said to be conformable for addition $A+B$, if they are of the same order and their sum is obtained by adding their corresponding elements.

Order of matrix $A+B$ will be the same as the order of matrices A and B .

6.3.1 Add and Subtract Matrices

Addition of Matrices:

When two matrices are conformable for addition, we find addition by adding their corresponding elements.

For example:

$$(i) \quad \begin{bmatrix} w & x \\ y & z \end{bmatrix} + \begin{bmatrix} a & b \\ c & d \end{bmatrix} = \begin{bmatrix} w+a & x+b \\ y+c & z+d \end{bmatrix}$$

$$(ii) \quad \begin{bmatrix} -3 & 0 & 1 \\ 5 & 2 & -4 \end{bmatrix} + \begin{bmatrix} 5 & 3 & -2 \\ -2 & 0 & 5 \end{bmatrix} = \begin{bmatrix} 2 & 3 & -1 \\ 3 & 2 & 1 \end{bmatrix}$$

$$(iii) \quad \begin{bmatrix} 1 & 2 & 4 \\ 2 & -3 & 5 \\ 3 & 4 & 7 \end{bmatrix} + \begin{bmatrix} 3 & -2 & -5 \\ -5 & 2 & 1 \\ -1 & -3 & -2 \end{bmatrix}$$

$$= \begin{bmatrix} 1+3 & 2+(-2) & 4+(-5) \\ 2+(-5) & -3+2 & 5+1 \\ 3+(-1) & 4+(-3) & 7+(-2) \end{bmatrix} = \begin{bmatrix} 4 & 0 & -1 \\ -3 & -1 & 6 \\ 2 & 1 & 5 \end{bmatrix}$$

Subtraction of Matrices:

If two matrices A and B are of the same order then their difference can be written as $A-B$.

The difference $A-B$ is obtained by subtracting the elements of B from the corresponding elements of matrix A .

EXAMPLE-1 If $A = \begin{bmatrix} 1 & x \\ y & 4 \end{bmatrix}$ $B = \begin{bmatrix} a & 2 \\ 3 & b \end{bmatrix}$ then find $A - B$

SOLUTION: $A - B = \begin{bmatrix} 1 & x \\ y & 4 \end{bmatrix} - \begin{bmatrix} a & 2 \\ 3 & b \end{bmatrix}$

$$A - B = \begin{bmatrix} 1 - a & x - 2 \\ y - 3 & 4 - b \end{bmatrix}$$

EXAMPLE-2 If $A = \begin{bmatrix} 2 & 7 & 3 \\ -1 & 3 & 4 \\ 0 & 4 & -2 \end{bmatrix}$ and $B = \begin{bmatrix} 1 & 3 & 5 \\ 2 & 1 & 6 \\ -1 & 8 & 3 \end{bmatrix}$ then find $A - B$

SOLUTION: $A - B = \begin{bmatrix} 2 & 7 & 3 \\ -1 & 3 & 4 \\ 0 & 4 & -2 \end{bmatrix} - \begin{bmatrix} 1 & 3 & 5 \\ 2 & 1 & 6 \\ -1 & 8 & 3 \end{bmatrix}$

$$= \begin{bmatrix} 2-1 & 7-3 & 3-5 \\ -1-2 & 3-1 & 4-6 \\ 0-(-1) & 4-8 & -2-3 \end{bmatrix}$$

$$A - B = \begin{bmatrix} 1 & 4 & -2 \\ -3 & 2 & -2 \\ 1 & -4 & -5 \end{bmatrix}$$

EXAMPLE-3 Add the matrices A, B and C where

$$A = \begin{bmatrix} 2 & 1 \\ 3 & 4 \end{bmatrix}, \quad B = \begin{bmatrix} 1 & 3 \\ -2 & 5 \end{bmatrix}, \quad C = \begin{bmatrix} 2 & -6 \\ -4 & 1 \end{bmatrix}$$

SOLUTION: Since A, B and C matrices have the same order, so they are conformable for addition

$$A + B + C = \begin{bmatrix} 2 & 1 \\ 3 & 4 \end{bmatrix} + \begin{bmatrix} 1 & 3 \\ -2 & 5 \end{bmatrix} + \begin{bmatrix} 2 & -6 \\ -4 & 1 \end{bmatrix}$$

$$= \begin{bmatrix} 2+1+2 & 1+3-6 \\ 3-2-4 & 4+5+1 \end{bmatrix}$$

$$= \begin{bmatrix} 5 & -2 \\ -3 & 10 \end{bmatrix}$$

EXAMPLE-4

Subtract matrix B from matrix A .

$$A = \begin{bmatrix} 2 & 4 & 7 \\ 1 & 3 & -2 \\ 4 & 5 & 6 \end{bmatrix}, \quad B = \begin{bmatrix} 11 & -5 & 2 \\ 2 & 4 & -6 \\ 3 & 6 & -1 \end{bmatrix}$$

SOLUTION: Since A and B have the same order, so they are conformable for subtraction.

$$A - B = \begin{bmatrix} 2 & 4 & 7 \\ 1 & 3 & -2 \\ 4 & 5 & 6 \end{bmatrix} - \begin{bmatrix} 11 & -5 & 2 \\ 2 & 4 & -6 \\ 3 & 6 & -1 \end{bmatrix}$$

$$= \begin{bmatrix} 2-11 & 4+5 & 7-2 \\ 1-2 & 3-4 & -2+6 \\ 4-3 & 5-6 & 6+1 \end{bmatrix}$$

$$A - B = \begin{bmatrix} -9 & 9 & 5 \\ -1 & -1 & 4 \\ 1 & -1 & 7 \end{bmatrix}$$

A Scalar Multiplication

Any element from the set of real numbers is also called a scalar. We define the product of a matrix A and a scalar k , denoted by kA , to be the matrix formed by multiplying each element of $A \times k$.

For example:

$$(i) \text{ If } A = \begin{bmatrix} a & b \\ c & d \end{bmatrix}, \text{ then } kA = \begin{bmatrix} ka & kb \\ kc & kd \end{bmatrix}$$

$$(ii) \text{ If } A = \begin{bmatrix} 4 & 3 & 2 \\ 2 & 6 & -1 \\ -3 & 4 & 7 \end{bmatrix}, \text{ then } 3A = \begin{bmatrix} 12 & 9 & 6 \\ 6 & 18 & -3 \\ -9 & 12 & 21 \end{bmatrix}$$

6.3.2 Laws of Addition of Matrices

Commutative Law:

For any two matrices A and B of the same order

$$A + B = B + A$$

This law is called commutative law of matrices with respect to addition.

EXAMPLE-1

$$\text{If } A = \begin{bmatrix} 1 & 3 \\ 4 & 5 \end{bmatrix} \text{ and } B = \begin{bmatrix} 4 & 2 \\ -6 & 1 \end{bmatrix}$$

then show that $A + B = B + A$.

SOLUTION: Matrices A, B have same order, so they are conformable for addition.

$$A + B = \begin{bmatrix} 1 & 3 \\ 4 & 5 \end{bmatrix} + \begin{bmatrix} 4 & 2 \\ -6 & 1 \end{bmatrix} = \begin{bmatrix} 1+4 & 3+2 \\ 4-6 & 5+1 \end{bmatrix}$$

$$\text{and } A + B = \begin{bmatrix} 5 & 5 \\ -2 & 6 \end{bmatrix}$$

$$B + A = \begin{bmatrix} 4 & 2 \\ -6 & 1 \end{bmatrix} + \begin{bmatrix} 1 & 3 \\ 4 & 5 \end{bmatrix} = \begin{bmatrix} 4+1 & 2+3 \\ -6+4 & 1+5 \end{bmatrix}$$

$$= \begin{bmatrix} 5 & 5 \\ -2 & 6 \end{bmatrix}$$

Thus $A + B = B + A$

Associative Law:

For three matrices A, B and C of same order,

$$(A + B) + C = A + (B + C)$$

This law is called associative law of matrices with respect to addition.

EXAMPLE If $A = \begin{bmatrix} 1 & 2 \\ 0 & 5 \end{bmatrix}$, $B = \begin{bmatrix} 4 & 0 \\ 0 & 2 \end{bmatrix}$, $C = \begin{bmatrix} 2 & 3 \\ -5 & -4 \end{bmatrix}$

then verify the associative law of matrices with respect to addition.

SOLUTION: $(A+B)+C = \left(\begin{bmatrix} 1 & 2 \\ 0 & 5 \end{bmatrix} + \begin{bmatrix} 4 & 0 \\ 0 & 2 \end{bmatrix} \right) + \begin{bmatrix} 2 & 3 \\ -5 & -4 \end{bmatrix}$

$$= \begin{bmatrix} 5 & 2 \\ 0 & 7 \end{bmatrix} + \begin{bmatrix} 2 & 3 \\ -5 & -4 \end{bmatrix}$$

$$(A+B)+C = \begin{bmatrix} 7 & 5 \\ -5 & 3 \end{bmatrix} \dots\dots\dots (i)$$

$$A+(B+C) = \begin{bmatrix} 1 & 2 \\ 0 & 5 \end{bmatrix} + \left(\begin{bmatrix} 4 & 0 \\ 0 & 2 \end{bmatrix} + \begin{bmatrix} 2 & 3 \\ -5 & -4 \end{bmatrix} \right)$$

$$= \begin{bmatrix} 1 & 2 \\ 0 & 5 \end{bmatrix} + \begin{bmatrix} 6 & 3 \\ -5 & -2 \end{bmatrix} = \begin{bmatrix} 7 & 5 \\ -5 & 3 \end{bmatrix} \dots\dots\dots (ii)$$

From (i) and (ii), we have $(A+B)+C = A+(B+C)$

6.3.3 Additive Identity of Matrices

In real numbers, zero is the additive identity i.e. the sum of a real number and zero is equal to the real number e.g, $5 + 0 = 0 + 5 = 5$. Similarly, a zero matrix O of order m - by - n is called the additive identity matrix such that

$$A + O = O + A = A$$

For example: $A = \begin{bmatrix} 3 & 5 \\ 2 & 4 \end{bmatrix}$

Consider, $A+O = \begin{bmatrix} 3 & 5 \\ 2 & 4 \end{bmatrix} + \begin{bmatrix} 0 & 0 \\ 0 & 0 \end{bmatrix}$

$$A+O = \begin{bmatrix} 3 & 5 \\ 2 & 4 \end{bmatrix} = A$$

and, $O+A = \begin{bmatrix} 0 & 0 \\ 0 & 0 \end{bmatrix} + \begin{bmatrix} 3 & 5 \\ 2 & 4 \end{bmatrix} = \begin{bmatrix} 3 & 5 \\ 2 & 4 \end{bmatrix} = A$

Thus $A + O = O + A = A$ so ' O ' is additive identity of matrix A .

Remember that: The order of 'A' and 'O' is same.

6.3.4 Additive Inverse of a Matrix

If two matrices A and B are such that their sum ($A + B$) is a zero matrix, then A and B are called additive inverse of each other.

For example:

$$A = \begin{bmatrix} a & b \\ c & d \end{bmatrix}, \text{ and } B = \begin{bmatrix} -a & -b \\ -c & -d \end{bmatrix}$$

Consider $A + B = \begin{bmatrix} a & b \\ c & d \end{bmatrix} + \begin{bmatrix} -a & -b \\ -c & -d \end{bmatrix} = \begin{bmatrix} 0 & 0 \\ 0 & 0 \end{bmatrix} = O$

Therefore A and B are inverse of each other.

EXAMPLE

If $A = \begin{bmatrix} -1 & 2 & -3 \\ 2 & -4 & 5 \\ -2 & -1 & 7 \end{bmatrix}$, and $B = \begin{bmatrix} 1 & -2 & 3 \\ -2 & 4 & -5 \\ 2 & 1 & -7 \end{bmatrix}$

then

$$\begin{aligned} A + B &= \begin{bmatrix} -1 & 2 & -3 \\ 2 & -4 & 5 \\ -2 & -1 & 7 \end{bmatrix} + \begin{bmatrix} 1 & -2 & 3 \\ -2 & 4 & -5 \\ 2 & 1 & -7 \end{bmatrix} \\ &= \begin{bmatrix} -1+1 & 2-2 & -3+3 \\ 2-2 & -4+4 & 5-5 \\ -2+2 & -1+1 & 7-7 \end{bmatrix} = \begin{bmatrix} 0 & 0 & 0 \\ 0 & 0 & 0 \\ 0 & 0 & 0 \end{bmatrix} \end{aligned}$$

$$A + B = O$$

A and B are inverse of each other.

EXERCISE - 6.3

$$1. \text{ If } A = \begin{bmatrix} 2 & 3 & 4 \\ 1 & 5 & 5 \\ 4 & 9 & 3 \end{bmatrix} \quad B = \begin{bmatrix} 0 & 1 & 5 \\ 2 & 3 & 6 \\ 1 & 4 & -2 \end{bmatrix}$$

$$\text{Find (i) } A+B \quad \text{(ii) } A-B \quad \text{(iii) } B-A \\ \text{(iv) } 2A+3B \quad \text{(v) } 3A-4B \quad \text{(vi) } A-2B$$

2- Find the additive inverses of the following matrices.

$$A = \begin{bmatrix} 4 & 3 \\ 2 & 6 \end{bmatrix}, B = \begin{bmatrix} \sqrt{2} & 3 \\ 4 & \sqrt{3} \end{bmatrix}, C = \begin{bmatrix} 1 \\ -7 \\ 4 \end{bmatrix}$$

$$D = \begin{bmatrix} 1 & 0 & -2 \\ 0 & 3 & 4 \\ 2 & -1 & -3 \end{bmatrix}, E = [2 \ 5 \ -3]$$

$$3- \text{ If } A = \begin{bmatrix} 2 & 3 \\ 1 & 5 \end{bmatrix} \text{ and } B = \begin{bmatrix} 1 & 7 \\ 4 & 6 \end{bmatrix} \text{ then show that}$$

$$(i) \ 4A - 3A = A \quad (ii) \ 3B - 3A = 3(B - A)$$

$$4- \text{ Find } x \text{ and } y \text{ if } \begin{bmatrix} x+3 & 1 \\ -3 & 3y-4 \end{bmatrix} = \begin{bmatrix} 2 & 1 \\ -3 & 2 \end{bmatrix}$$

$$5- \text{ If } A = \begin{bmatrix} 1 & 3 \\ 4 & 5 \end{bmatrix}, B = \begin{bmatrix} 4 & 7 \\ 6 & 5 \end{bmatrix}, C = \begin{bmatrix} 2 & 6 \\ 3 & -2 \end{bmatrix} \text{ then prove that,}$$

$$(i) \ A+B = B+A \quad (ii) \ A+(B+C) = (A+B)+C$$

6- Solve the matrix equation for X .

$$3X - 2A = B \text{ if } A = \begin{bmatrix} 2 & 3 \\ -4 & 1 \end{bmatrix} \text{ and } B = \begin{bmatrix} 2 & -3 \\ 4 & 4 \end{bmatrix}$$

7- Find a, b, c, d, e and f such that

$$\begin{bmatrix} a & b & c \\ d & e & f \end{bmatrix} - \begin{bmatrix} 3 & -2 & 1 \\ 5 & 0 & -4 \end{bmatrix} = \begin{bmatrix} -1 & -2 & 3 \\ -2 & 4 & 6 \end{bmatrix}$$

8- Find w, x, y, z such that

$$\begin{bmatrix} w & x \\ y & z \end{bmatrix} + \begin{bmatrix} 3 & 0 \\ -1 & 5 \end{bmatrix} = \begin{bmatrix} 2 & 1 \\ 6 & -3 \end{bmatrix}$$

9- If $A = \begin{bmatrix} a & b \\ c & d \end{bmatrix}$ then what is the additive inverse of A ?

10- Given that $A = \begin{bmatrix} 1 & -1 \\ 2 & 3 \end{bmatrix}$ verify that $A^2 - 4A + 5I = 0$.

11- If $A = \begin{bmatrix} 2 & 4 \\ 1 & 5 \end{bmatrix}$, $B = \begin{bmatrix} 3 & -2 \\ 4 & 6 \end{bmatrix}$, then verify that $(A+B)^t = A^t + B^t$.

12- If $A = \begin{bmatrix} 1 & 2 \\ 3 & -4 \end{bmatrix}$, $B = \begin{bmatrix} 2 & -7 \\ 5 & 8 \end{bmatrix}$, $C = \begin{bmatrix} 1 & 5 \\ 0 & 2 \end{bmatrix}$ then show that

$$A+B-C = \begin{bmatrix} 2 & -10 \\ 8 & 2 \end{bmatrix}$$

6.4.1 MULTIPLICATION OF MATRICES

Two matrices A and B are said to be conformable for the product AB , if the number of columns in A is equal to the number of rows in B .

For example: $\begin{bmatrix} 2 & \rightarrow & 3 \end{bmatrix} \begin{bmatrix} \downarrow & 4 \\ & 2 \end{bmatrix} = [2 \times 4 + 3 \times 2]$
 $= [8 + 6]$
 $= [14]$

EXAMPLE-1

$$A = \begin{bmatrix} a_{11} & a_{12} \\ a_{21} & a_{22} \end{bmatrix}, B = \begin{bmatrix} b_{11} & b_{12} & b_{13} \\ b_{21} & b_{22} & b_{23} \end{bmatrix}$$

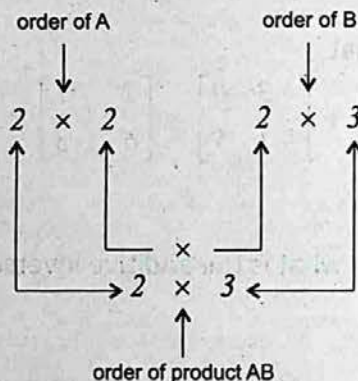

The product of AB shall contain the elements like

$$AB = \begin{bmatrix} c_{11} & c_{12} & c_{13} \\ c_{21} & c_{22} & c_{23} \end{bmatrix} \text{ where}$$

$$c_{11} = a_{11} b_{11} + a_{12} b_{21} \quad \text{(Multiplication of the elements of 1st row of A with elements of 1st column of B)}$$

$$c_{12} = a_{11} b_{12} + a_{12} b_{22} \quad \text{(Multiplication of the elements of 1st row of A with elements of 2nd column of B)}$$

$$c_{13} = a_{11} b_{13} + a_{12} b_{23} \quad \text{(Multiplication of the elements of 1st row of A with elements of 3rd column of B)}$$

$$c_{21} = a_{21} b_{11} + a_{22} b_{21}$$

$$c_{22} = a_{21} b_{12} + a_{22} b_{22}$$

$$c_{23} = a_{21} b_{13} + a_{22} b_{23} \text{ , thus}$$

$$AB = \begin{bmatrix} a_{11} & a_{12} \\ a_{21} & a_{22} \end{bmatrix} \begin{bmatrix} b_{11} & b_{12} & b_{13} \\ b_{21} & b_{22} & b_{23} \end{bmatrix}$$

$$= \begin{bmatrix} a_{11} b_{11} + a_{12} b_{21} & a_{11} b_{12} + a_{12} b_{22} & a_{11} b_{13} + a_{12} b_{23} \\ a_{21} b_{11} + a_{22} b_{21} & a_{21} b_{12} + a_{22} b_{22} & a_{21} b_{13} + a_{22} b_{23} \end{bmatrix}$$

EXAMPLE-2

If $A = \begin{bmatrix} 5 & 2 \\ 3 & 4 \end{bmatrix}$ and $B = \begin{bmatrix} 2 \\ 3 \end{bmatrix}$ then find AB .

SOLUTION: order of $A = 2 \times 2$

order of $B = 2 \times 1$

order of $AB = 2 \times 1$

Because number of columns in $A =$ number of rows in $B = 2$

$$AB = \begin{bmatrix} 5 & 2 \\ 3 & 4 \end{bmatrix} \begin{bmatrix} 2 \\ 3 \end{bmatrix} = \begin{bmatrix} 5 \times 2 + 2 \times 3 \\ 3 \times 2 + 4 \times 3 \end{bmatrix} = \begin{bmatrix} 10 + 6 \\ 6 + 12 \end{bmatrix} = \begin{bmatrix} 16 \\ 18 \end{bmatrix}$$

Result:

If A is a square matrix then $A^2 = A.A$

$$A^3 = A.A.A = AA^2 = A^2.A$$

Finally $A^n = A.A.A \dots \dots \dots n$ times.

Remember that:

For multiplication AB of two matrices A and B the following points should be kept in mind.

- (i) The number of columns in $A =$ number of rows in B .
- (ii) The product of matrices A and B is denoted by $A \times B$ or AB .
- (iii) If A is a $m \times p$ matrix and B is a $p \times n$ matrix then AB is $m \times n$ matrix.

6.4.3 Associative Law of Matrices with respect to Multiplication

If three matrices A , B and C are conformable for multiplication, then

$$A(BC) = (AB)C$$

is called associative law with respect to multiplication.

EXAMPLE

$$\text{If } A = \begin{bmatrix} 2 & 1 \\ 3 & 1 \end{bmatrix}, B = \begin{bmatrix} 1 & 1 \\ 2 & 3 \end{bmatrix} \text{ and } C = \begin{bmatrix} 4 & 2 \\ 3 & 1 \end{bmatrix}$$

then verify associative law under multiplication.

SOLUTION:

$$\text{Consider } A(BC) = \begin{bmatrix} 2 & 1 \\ 3 & 1 \end{bmatrix} \left(\begin{bmatrix} 1 & 1 \\ 2 & 3 \end{bmatrix} \begin{bmatrix} 4 & 2 \\ 3 & 1 \end{bmatrix} \right)$$

$$= \begin{bmatrix} 2 & 1 \\ 3 & 1 \end{bmatrix} \begin{bmatrix} 1 \times 4 + 1 \times 3 & 1 \times 2 + 1 \times 1 \\ 2 \times 4 + 3 \times 3 & 2 \times 2 + 3 \times 1 \end{bmatrix}$$

$$= \begin{bmatrix} 2 & 1 \\ 3 & 1 \end{bmatrix} \begin{bmatrix} 4+3 & 2+1 \\ 8+9 & 4+3 \end{bmatrix}$$

$$= \begin{bmatrix} 2 & 1 \\ 3 & 1 \end{bmatrix} \begin{bmatrix} 7 & 3 \\ 17 & 7 \end{bmatrix}$$

$$= \begin{bmatrix} 2 \times 7 + 1 \times 17 & 2 \times 3 + 1 \times 7 \\ 3 \times 7 + 1 \times 17 & 3 \times 3 + 1 \times 7 \end{bmatrix} = \begin{bmatrix} 14+17 & 6+7 \\ 21+17 & 9+7 \end{bmatrix}$$

$$A(BC) = \begin{bmatrix} 31 & 13 \\ 38 & 16 \end{bmatrix} \dots\dots\dots(i)$$

$$\text{Consider } (AB)C = \left(\begin{bmatrix} 2 & 1 \\ 3 & 1 \end{bmatrix} \begin{bmatrix} 1 & 1 \\ 2 & 3 \end{bmatrix} \right) \begin{bmatrix} 4 & 2 \\ 3 & 1 \end{bmatrix}$$

$$= \begin{bmatrix} 2 \times 1 + 1 \times 2 & 2 \times 1 + 1 \times 3 \\ 3 \times 1 + 1 \times 2 & 3 \times 1 + 1 \times 3 \end{bmatrix} \begin{bmatrix} 4 & 2 \\ 3 & 1 \end{bmatrix}$$

$$\begin{aligned}
 ABC &= \begin{bmatrix} 2+2 & 2+3 \\ 3+2 & 3+3 \end{bmatrix} \begin{bmatrix} 4 & 2 \\ 3 & 1 \end{bmatrix} \\
 &= \begin{bmatrix} 4 & 5 \\ 5 & 6 \end{bmatrix} \begin{bmatrix} 4 & 2 \\ 3 & 1 \end{bmatrix} \\
 &= \begin{bmatrix} 4 \times 4 + 5 \times 3 & 4 \times 2 + 5 \times 1 \\ 5 \times 4 + 6 \times 3 & 5 \times 2 + 6 \times 1 \end{bmatrix} = \begin{bmatrix} 16+15 & 8+5 \\ 20+18 & 10+6 \end{bmatrix} \\
 (AB)C &= \begin{bmatrix} 31 & 13 \\ 38 & 16 \end{bmatrix} \dots\dots\dots(ii)
 \end{aligned}$$

From equation (i) and (ii), $A(BC) = (AB)C$

Associative law holds in multiplication of matrices.

6.4.4 Distributive Laws

If the matrices A , B and C are conformable for addition and multiplication, then

(i) $A(B + C) = AB + AC$ (left distributive law for matrices).

(ii) $(A + B)C = AC + BC$ (right distributive law for matrices)

(i) and (ii) are called distributive laws.

EXAMPLE

If $A = \begin{bmatrix} 4 & 3 \\ 2 & 2 \end{bmatrix}$, $B = \begin{bmatrix} 2 & 3 \\ -1 & -2 \end{bmatrix}$ and $C = \begin{bmatrix} -1 & -4 \\ 3 & 6 \end{bmatrix}$

then verify left and right distributive laws.

SOLUTION: (i) Left distributive law $A(B + C) = AB + AC$

$$B + C = \begin{bmatrix} 2 & 3 \\ -1 & -2 \end{bmatrix} + \begin{bmatrix} -1 & -4 \\ 3 & 6 \end{bmatrix}$$

$$B+C = \begin{bmatrix} 2-1 & 3-4 \\ -1+3 & -2+6 \end{bmatrix} = \begin{bmatrix} 1 & -1 \\ 2 & 4 \end{bmatrix}$$

$$\text{Consider } A(B+C) = \begin{bmatrix} 4 & 3 \\ 2 & 2 \end{bmatrix} \begin{bmatrix} 1 & -1 \\ 2 & 4 \end{bmatrix}$$

$$= \begin{bmatrix} 4+6 & -4+12 \\ 2+4 & -2+8 \end{bmatrix}$$

$$= \begin{bmatrix} 10 & 8 \\ 6 & 6 \end{bmatrix} \dots\dots\dots (i)$$

$$\text{Consider } AB+AC = \begin{bmatrix} 4 & 3 \\ 2 & 2 \end{bmatrix} \begin{bmatrix} 2 & 3 \\ -1 & -2 \end{bmatrix} + \begin{bmatrix} 4 & 3 \\ 2 & 2 \end{bmatrix} \begin{bmatrix} -1 & -4 \\ 3 & 6 \end{bmatrix}$$

$$= \begin{bmatrix} 8-3 & 12-6 \\ 4-2 & 6-4 \end{bmatrix} + \begin{bmatrix} -4+9 & -16+18 \\ -2+6 & -8+12 \end{bmatrix}$$

$$= \begin{bmatrix} 5 & 6 \\ 2 & 2 \end{bmatrix} + \begin{bmatrix} 5 & 2 \\ 4 & 4 \end{bmatrix}$$

$$= \begin{bmatrix} 10 & 8 \\ 6 & 6 \end{bmatrix} \dots\dots\dots (ii)$$

From equations (i) and (ii)
 $A(B+C) = AB+AC.$

(ii) Right distributive law $(A + B)C = AC + BC$

$$A + B = \begin{bmatrix} 4 & 3 \\ 2 & 2 \end{bmatrix} + \begin{bmatrix} 2 & 3 \\ -1 & -2 \end{bmatrix} = \begin{bmatrix} 6 & 6 \\ 1 & 0 \end{bmatrix}$$

$$\text{Consider } (A + B)C = \begin{bmatrix} 6 & 6 \\ 1 & 0 \end{bmatrix} \begin{bmatrix} -1 & -4 \\ 3 & 6 \end{bmatrix}$$

$$= \begin{bmatrix} -6 + 18 & -24 + 36 \\ -1 + 0 & -4 + 0 \end{bmatrix}$$

$$= \begin{bmatrix} 12 & 12 \\ -1 & -4 \end{bmatrix} \dots\dots\dots (i)$$

$$\text{Consider } AC + BC = \begin{bmatrix} 4 & 3 \\ 2 & 2 \end{bmatrix} \begin{bmatrix} -1 & -4 \\ 3 & 6 \end{bmatrix} + \begin{bmatrix} 2 & 3 \\ -1 & -2 \end{bmatrix} \begin{bmatrix} -1 & -4 \\ 3 & 6 \end{bmatrix}$$

$$= \begin{bmatrix} -4 + 9 & -16 + 18 \\ -2 + 6 & -8 + 12 \end{bmatrix} + \begin{bmatrix} -2 + 9 & -8 + 18 \\ 1 - 6 & 4 - 12 \end{bmatrix}$$

$$= \begin{bmatrix} 5 & 2 \\ 4 & 4 \end{bmatrix} + \begin{bmatrix} 7 & 10 \\ -5 & -8 \end{bmatrix}$$

$$= \begin{bmatrix} 12 & 12 \\ -1 & -4 \end{bmatrix} \dots\dots\dots (ii)$$

From equations (i) and (ii)
 $(A + B)C = AC + BC$.

6.4.5 Commutative Law

Commutative law does not hold in multiplication of matrices in general
i.e. $AB \neq BA$

EXAMPLE-1 $A = \begin{bmatrix} 1 & 2 \\ 3 & -2 \end{bmatrix}$ $B = \begin{bmatrix} -1 & 3 \\ 4 & 2 \end{bmatrix}$ verify $AB \neq BA$.

SOLUTION: Given matrices A and B are conformable for multiplication AB and BA .

Consider $AB = \begin{bmatrix} 1 & 2 \\ 3 & -2 \end{bmatrix} \begin{bmatrix} -1 & 3 \\ 4 & 2 \end{bmatrix}$

$$= \begin{bmatrix} -1+8 & 3+4 \\ -3-8 & 9-4 \end{bmatrix}$$

$$AB = \begin{bmatrix} 7 & 7 \\ -11 & 5 \end{bmatrix} \dots\dots\dots(i)$$

Consider $BA = \begin{bmatrix} -1 & 3 \\ 4 & 2 \end{bmatrix} \begin{bmatrix} 1 & 2 \\ 3 & -2 \end{bmatrix}$

$$= \begin{bmatrix} -1+9 & -2-6 \\ 4+6 & 8-4 \end{bmatrix}$$

$$BA = \begin{bmatrix} 8 & -8 \\ 10 & 4 \end{bmatrix} \dots\dots\dots(ii)$$

From equations (i) and (ii)

$$AB \neq BA$$

Hence commutative law does not hold in multiplication of matrices, in general.

EXAMPLE-2

If $A = \begin{bmatrix} a & b \\ c & d \end{bmatrix}$, then verify $I_2A = AI_2 = A$

SOLUTION:

$$\begin{aligned} \text{Consider } I_2A &= \begin{bmatrix} 1 & 0 \\ 0 & 1 \end{bmatrix} \begin{bmatrix} a & b \\ c & d \end{bmatrix} \\ &= \begin{bmatrix} 1 \times a + 0 \times c & 1 \times b + 0 \times d \\ 0 \times a + 1 \times c & 0 \times b + 1 \times d \end{bmatrix} \\ &= \begin{bmatrix} a & b \\ c & d \end{bmatrix} \end{aligned}$$

$$I_2A = A \dots\dots\dots(i)$$

$$\begin{aligned} \text{Consider } AI_2 &= \begin{bmatrix} a & b \\ c & d \end{bmatrix} \begin{bmatrix} 1 & 0 \\ 0 & 1 \end{bmatrix} \\ &= \begin{bmatrix} a \times 1 + b \times 0 & a \times 0 + b \times 1 \\ c \times 1 + d \times 0 & c \times 0 + d \times 1 \end{bmatrix} \\ &= \begin{bmatrix} a & b \\ c & d \end{bmatrix} \end{aligned}$$

$$AI_2 = A \dots\dots\dots(ii)$$

From equations (i) and (ii)

$$I_2A = AI_2 = A$$

6.4.7 Theorem

$(AB)' = B' A'$ where A and B are two matrices.

EXAMPLE

If $A = \begin{bmatrix} 2 & 3 \\ 1 & -2 \end{bmatrix}$ and $B = \begin{bmatrix} -1 & 3 \\ 2 & 1 \end{bmatrix}$, then

show that $(AB)' = B' A'$

SOLUTION:

$$\begin{aligned} \text{Consider } AB &= \begin{bmatrix} 2 & 3 \\ 1 & -2 \end{bmatrix} \begin{bmatrix} -1 & 3 \\ 2 & 1 \end{bmatrix} \\ &= \begin{bmatrix} -2+6 & 6+3 \\ -1-4 & 3-2 \end{bmatrix} \end{aligned}$$

$$AB = \begin{bmatrix} 4 & 9 \\ -5 & 1 \end{bmatrix}$$

$$\text{L.H.S} = (AB)' = \begin{bmatrix} 4 & 9 \\ -5 & 1 \end{bmatrix}' = \begin{bmatrix} 4 & -5 \\ 9 & 1 \end{bmatrix} \dots\dots\dots (i)$$

$$\text{Now } A' = \begin{bmatrix} 2 & 1 \\ 3 & -2 \end{bmatrix}, B' = \begin{bmatrix} -1 & 2 \\ 3 & 1 \end{bmatrix}$$

$$\begin{aligned} \text{Consider R.H.S} &= B' A' = \begin{bmatrix} -1 & 2 \\ 3 & 1 \end{bmatrix} \begin{bmatrix} 2 & 1 \\ 3 & -2 \end{bmatrix} \\ &= \begin{bmatrix} -2+6 & -1-4 \\ 6+3 & 3-2 \end{bmatrix} \\ &= \begin{bmatrix} 4 & -5 \\ 9 & 1 \end{bmatrix} \dots\dots\dots (ii) \end{aligned}$$

From (i) and (ii)

$$(AB)' = B' A'$$

EXERCISE - 6.4

In Problems 1 to 8 Verify Each Statement, Using

$$A = \begin{bmatrix} 4 & 2 \\ 0 & 0 \end{bmatrix}, \quad B = \begin{bmatrix} 2 & 1 \\ -2 & 4 \end{bmatrix}, \quad C = \begin{bmatrix} -1 & 2 \\ 4 & 2 \end{bmatrix}$$

1. $(AB)C = A(BC)$

2. $AB \neq BA$

3. $A(B+C) = AB+AC$

4. $(B+C)A = BA+CA$

5. $(B+C)(B-C) \neq B^2 - C^2$

6. $(BC)^t = C^t B^t$

7. $BI = B$

8. $BC \neq CB$

Find the Matrix Products.

9. $\begin{bmatrix} 2 & 5 \end{bmatrix} \begin{bmatrix} 1 & -1 \\ 2 & 3 \end{bmatrix}$

10. $\begin{bmatrix} 3 & 4 \\ -1 & -2 \end{bmatrix} \begin{bmatrix} -1 \\ 2 \end{bmatrix}$

11. $\begin{bmatrix} 2 & -3 \\ 1 & 2 \end{bmatrix} \begin{bmatrix} 1 & -1 \\ 0 & -2 \end{bmatrix}$

12. $\begin{bmatrix} -3 & 2 \\ 4 & -1 \end{bmatrix} \begin{bmatrix} -1 & 5 \\ -1 & 3 \end{bmatrix}$

13. $\begin{bmatrix} -5 & -2 \\ 1 & -3 \end{bmatrix} \begin{bmatrix} -2 & 1 \\ 0 & -3 \end{bmatrix}$

14. $\begin{bmatrix} -2 & 4 \\ 0 & -3 \end{bmatrix} \begin{bmatrix} -5 & -5 \\ 1 & -3 \end{bmatrix} \begin{bmatrix} 1 & -1 \\ 2 & -0 \end{bmatrix}$

15. If $\begin{bmatrix} 1 & 5 \\ 3 & a \end{bmatrix} \begin{bmatrix} b \\ 7 \end{bmatrix} = \begin{bmatrix} 35 \\ 10 \end{bmatrix}$, then find the values of a and b .

16. If $A = \begin{bmatrix} 2 & 6 \\ 7 & 8 \end{bmatrix}$, $B = \begin{bmatrix} -1 & -3 \\ 2 & 0 \end{bmatrix}$, then verify $(AB)^t = B^t A^t$.

6.5 MULTIPLICATIVE INVERSE OF A MATRIX

6.5.1 Determinant Function

In this section, we are going to define a new function, called a determinant of a square matrix. Its domain is the set of all square matrices with real elements, and its range is the set of all real numbers.

If A is a square matrix, then $\det A$ or $|A|$ read "The determinant of A " is used to denote the unique real number.

The determinant of a matrix of order 2 is defined as follows.

$$\det \begin{bmatrix} a & b \\ c & d \end{bmatrix} = \begin{vmatrix} a & b \\ c & d \end{vmatrix} \\ = ad - bc$$

6.5.2 Evaluate Determinant of a Matrix

EXAMPLE-1

If $A = \begin{bmatrix} -1 & 2 \\ -3 & -4 \end{bmatrix}$, then evaluate $\det A$.

SOLUTION: $|A| = \begin{vmatrix} -1 & 2 \\ -3 & -4 \end{vmatrix} = (-1) \times (-4) - (-3) \times 2 \\ = 4 + 6 = 10$

EXAMPLE-2

If $A = \begin{bmatrix} 6 & 2 \\ 4 & 2 \end{bmatrix}$, then evaluate $\det A$.

SOLUTION: $\det A = \begin{vmatrix} 6 & 2 \\ 4 & 2 \end{vmatrix} = 12 - 8 = 4$

EXAMPLE-3

If $A = \begin{bmatrix} 5 & 2 \\ 10 & 4 \end{bmatrix}$, then evaluate $\det A$.

SOLUTION: $\det A = \begin{vmatrix} 5 & 2 \\ 10 & 4 \end{vmatrix} = 20 - 20 = 0$

6.5.3 Singular and Non-Singular Matrices

Singular Matrix:

A square matrix A is called a singular matrix. If $\det A = 0$

EXAMPLE

$$\text{If } A = \begin{bmatrix} 12 & 6 \\ 6 & 3 \end{bmatrix}$$

$$\det A = \begin{vmatrix} 12 & 6 \\ 6 & 3 \end{vmatrix} = 36 - 36$$

$\det A = 0$. Hence matrix A is singular.

Non-Singular Matrix:

A square matrix A is called non-singular matrix, if $\det A \neq 0$.

EXAMPLE

$$\text{If } A = \begin{bmatrix} 2 & 5 \\ 6 & 8 \end{bmatrix}$$

$$\det A = \begin{vmatrix} 2 & 5 \\ 6 & 8 \end{vmatrix} = 16 - 30$$

$\det A = -14 \neq 0$. Hence matrix A is non-singular.

6.5.4 Adjoint of a Matrix

Let $A = \begin{bmatrix} a & b \\ c & d \end{bmatrix}$ be a square matrix of order 2×2 . Then the matrix

obtained by interchanging the elements of the diagonal (i.e. a and d) and by changing the signs of the other elements b and c is called the adjoint of the matrix A .

The adjoint of the matrix A is denoted by $\text{adj } A$. For example:

$$\text{If } A = \begin{bmatrix} a & b \\ c & d \end{bmatrix}, \text{ then } \text{adj } A = \begin{bmatrix} d & -b \\ -c & a \end{bmatrix}.$$

Look at another example:

$$\text{If } P = \begin{bmatrix} -6 & -2 \\ 3 & 4 \end{bmatrix}, \text{ then } \text{adj } P = \begin{bmatrix} 4 & 2 \\ -3 & -6 \end{bmatrix}$$

6.5.5 Multiplicative Inverse

In the set of real numbers, we know that for each real number a (except zero) there exists a real number a^{-1} such that $aa^{-1} = 1$. The number a^{-1} is called the multiplicative inverse of a .

Similarly, each square matrix A has a multiplicative inverse A^{-1} such that $AA^{-1} = A^{-1}A = I$, provided $\det A \neq 0$.

Multiplicative inverse A^{-1} of any non-singular matrix A is given by

$$A^{-1} = \frac{\text{adj } A}{|A|}, \quad |A| \neq 0$$

If A is a singular matrix then the multiplicative inverse of A does not exist.

Remember That:

- (i) Inverse of square matrix A is denoted by A^{-1} .
- (ii) Only non-singular matrices have inverses.
- (iii) Inverse of square matrix A is always unique.
- (iv) Non-square matrices cannot possess inverses.
- (v) $A^{-1} = \frac{\text{adj } A}{|A|}$

EXAMPLE

If $A = \begin{bmatrix} 4 & 2 \\ 5 & 4 \end{bmatrix}$, then verify $AA^{-1} = A^{-1}A = I$

where I is the identity matrix.

SOLUTION:

$$A = \begin{bmatrix} 4 & 2 \\ 5 & 4 \end{bmatrix}; \quad \text{adj } A = \begin{bmatrix} 4 & -2 \\ -5 & 4 \end{bmatrix}$$

$$|A| = \begin{vmatrix} 4 & 2 \\ 5 & 4 \end{vmatrix}$$

$$= 16 - 10$$

$$|A| = 6 \neq 0$$

We have $A^{-1} = \frac{1}{|A|} \text{adj } A$

$$A^{-1} = \frac{1}{6} \begin{bmatrix} 4 & -2 \\ -5 & 4 \end{bmatrix}$$

Consider $AA^{-1} = \frac{1}{6} \begin{bmatrix} 4 & 2 \\ 5 & 4 \end{bmatrix} \begin{bmatrix} 4 & -2 \\ -5 & 4 \end{bmatrix}$

$$= \frac{1}{6} \begin{bmatrix} 16-10 & -8+8 \\ 20-20 & -10+16 \end{bmatrix} = \frac{1}{6} \begin{bmatrix} 6 & 0 \\ 0 & 6 \end{bmatrix}$$

$$AA^{-1} = \begin{bmatrix} 1 & 0 \\ 0 & 1 \end{bmatrix}$$

$$AA^{-1} = I \dots\dots\dots(i)$$

Now

Consider $A^{-1}A = \frac{1}{6} \begin{bmatrix} 4 & -2 \\ -5 & 4 \end{bmatrix} \begin{bmatrix} 4 & 2 \\ 5 & 4 \end{bmatrix}$

$$A^{-1}A = \frac{1}{6} \begin{bmatrix} 16-10 & 8-8 \\ -20+20 & -10+16 \end{bmatrix} = \frac{1}{6} \begin{bmatrix} 6 & 0 \\ 0 & 6 \end{bmatrix} = \begin{bmatrix} 1 & 0 \\ 0 & 1 \end{bmatrix}$$

$$A^{-1}A = I \dots\dots\dots(ii)$$

From equation (i) and (ii) $AA^{-1} = I = A^{-1}A$.

6.5.6 Inverse of a Non-Singular Matrix

The matrix $\begin{bmatrix} a & b \\ c & d \end{bmatrix}$ has the inverse $\frac{1}{ad-bc} \begin{bmatrix} d & -b \\ -c & a \end{bmatrix}$, provided, $ad-bc \neq 0$.

EXAMPLE-1

If $A = \begin{bmatrix} 7 & 3 \\ 14 & 9 \end{bmatrix}$, then find inverse of matrix A .

SOLUTION: $A = \begin{bmatrix} 7 & 3 \\ 14 & 9 \end{bmatrix}$, then $\text{adj } A = \begin{bmatrix} 9 & -3 \\ -14 & 7 \end{bmatrix}$

$$|A| = \begin{vmatrix} 7 & 3 \\ 14 & 9 \end{vmatrix}$$

$$|A| = 63 - 42 = 21 \neq 0$$

We know that $A^{-1} = \frac{1}{|A|} \text{adj } A$

$$= \frac{1}{21} \begin{bmatrix} 9 & -3 \\ -14 & 7 \end{bmatrix}$$

$$A^{-1} = \begin{bmatrix} \frac{9}{21} & \frac{-3}{21} \\ \frac{-14}{21} & \frac{7}{21} \end{bmatrix} = \begin{bmatrix} \frac{3}{7} & \frac{-1}{7} \\ \frac{-2}{3} & \frac{1}{3} \end{bmatrix}$$

EXAMPLE-2

If $B = \begin{bmatrix} 3 & -4 \\ -3 & -2 \end{bmatrix}$, then find B^{-1} .

SOLUTION:

$$B = \begin{bmatrix} 3 & -4 \\ -3 & -2 \end{bmatrix} \quad \text{adj } B = \begin{bmatrix} -2 & 4 \\ 3 & 3 \end{bmatrix}$$

$$|B| = \begin{vmatrix} 3 & -4 \\ -3 & -2 \end{vmatrix}$$

$$|B| = -6 - 12 = -18 \neq 0$$

We know that $B^{-1} = \frac{1}{|B|} \text{adj } B$

$$= \frac{1}{-18} \begin{bmatrix} -2 & 4 \\ 3 & 3 \end{bmatrix}$$

$$= \begin{bmatrix} \frac{-2}{-18} & \frac{4}{-18} \\ \frac{3}{-18} & \frac{3}{-18} \end{bmatrix}$$

$$B^{-1} = \begin{bmatrix} \frac{1}{9} & \frac{-2}{9} \\ \frac{-1}{6} & \frac{-1}{6} \end{bmatrix}$$

EXAMPLE-3

If $P = \begin{bmatrix} 3 & 2 \\ 6 & 4 \end{bmatrix}$, then find P^{-1} if possible.

SOLUTION:

$$P = \begin{bmatrix} 3 & 2 \\ 6 & 4 \end{bmatrix}, \quad \text{adj } P = \begin{bmatrix} 4 & -2 \\ -6 & 3 \end{bmatrix}$$

$$|P| = \begin{vmatrix} 3 & 2 \\ 6 & 4 \end{vmatrix}$$

$$= 3 \times 4 - 2 \times 6 = 12 - 12 = 0$$

Since $|P| = 0$

The inverse of P is not defined,

because $\frac{1}{0}$ is not defined.

6.5.7 Verify $(AB)^{-1} = B^{-1}A^{-1}$

We verify this with the help of following example.

EXAMPLE

If $A = \begin{bmatrix} 3 & 6 \\ 2 & 1 \end{bmatrix}$, $B = \begin{bmatrix} 4 & 2 \\ 5 & 4 \end{bmatrix}$, then verify $(AB)^{-1} = B^{-1}A^{-1}$.

SOLUTION:

$$AB = \begin{bmatrix} 3 & 6 \\ 2 & 1 \end{bmatrix} \begin{bmatrix} 4 & 2 \\ 5 & 4 \end{bmatrix}$$

$$AB = \begin{bmatrix} 12+30 & 6+24 \\ 8+5 & 4+4 \end{bmatrix} = \begin{bmatrix} 42 & 30 \\ 13 & 8 \end{bmatrix}$$

$$|AB| = \begin{vmatrix} 42 & 30 \\ 13 & 8 \end{vmatrix} = 42 \times 8 - 13 \times 30$$

$$= 336 - 390$$

$$= -54 \neq 0$$

Consider $L.H.S = (AB)^{-1} = \frac{1}{|AB|} \text{adj}(AB)$

$$(AB)^{-1} = \frac{1}{-54} \begin{bmatrix} 8 & -30 \\ -13 & 42 \end{bmatrix} \dots\dots\dots(i)$$

$$A = \begin{bmatrix} 3 & 6 \\ 2 & 1 \end{bmatrix}, \quad \text{adj } A = \begin{bmatrix} 1 & -6 \\ -2 & 3 \end{bmatrix}$$

$$|A| = \begin{vmatrix} 3 & 6 \\ 2 & 1 \end{vmatrix} = 3 - 12 \\ = -9 \neq 0$$

$$A^{-1} = \frac{\text{adj } A}{|A|}$$

$$A^{-1} = \frac{1}{-9} \begin{bmatrix} 1 & -6 \\ -2 & 3 \end{bmatrix}$$

$$B = \begin{bmatrix} 4 & 2 \\ 5 & 4 \end{bmatrix}, \quad \text{adj } B = \begin{bmatrix} 4 & -2 \\ -5 & 4 \end{bmatrix}$$

$$|B| = \begin{vmatrix} 4 & 2 \\ 5 & 4 \end{vmatrix} = 16 - 10 = 6$$

Now $B^{-1} = \frac{\text{adj } B}{|B|}$

$$B^{-1} = \frac{1}{6} \begin{bmatrix} 4 & -2 \\ -5 & 4 \end{bmatrix}$$

Consider $B^{-1}A^{-1} = \frac{1}{6} \begin{bmatrix} 4 & -2 \\ -5 & 4 \end{bmatrix} \left(\frac{1}{-9} \right) \begin{bmatrix} 1 & -6 \\ -2 & 3 \end{bmatrix}$

$$= -\frac{1}{54} \begin{bmatrix} 4 & -2 \\ -5 & 4 \end{bmatrix} \begin{bmatrix} 1 & -6 \\ -2 & 3 \end{bmatrix}$$

$$= -\frac{1}{54} \begin{bmatrix} 4+4 & -24-6 \\ -5-8 & 30+12 \end{bmatrix}$$

$$B^{-1}A^{-1} = \frac{-1}{54} \begin{bmatrix} 8 & -30 \\ -13 & 42 \end{bmatrix} \dots\dots\dots(ii)$$

From (i) and (ii)

$$(AB)^{-1} = B^{-1}A^{-1}$$

EXERCISE - 6.5

1- Find the determinants of the following matrices.

$$(i) \begin{bmatrix} u & v \\ x & y \end{bmatrix} \quad (ii) \begin{bmatrix} -2 & 5 \\ 1 & 4 \end{bmatrix} \quad (iii) \begin{bmatrix} -8 & -4 \\ -4 & -2 \end{bmatrix} \quad (iv) \begin{bmatrix} 1 & 3 \\ 1 & 8 \\ 1 & 1 \\ 8 & 4 \end{bmatrix}$$

2. Identify the singular and non-singular matrices.

$$(i) \begin{bmatrix} -1 & 3 \\ 1 & -3 \end{bmatrix} \quad (ii) \begin{bmatrix} 3 & 8 \\ 4 & 9 \end{bmatrix} \quad (iii) \begin{bmatrix} -a & b \\ a & b \end{bmatrix}$$

3. Find the inverse of each matrix A and show that $A^{-1}A = I$.
If the inverse does not exist, give reason.

$$(i) \begin{bmatrix} 1 & 2 \\ 1 & 3 \end{bmatrix} \quad (ii) \begin{bmatrix} 2 & 1 \\ 5 & 3 \end{bmatrix} \quad (iii) \begin{bmatrix} 2 & 0 \\ -1 & 3 \end{bmatrix}$$

$$(iv) \begin{bmatrix} -6 & 4 \\ 3 & -2 \end{bmatrix} \quad (v) \begin{bmatrix} 1 & 3 \\ 2 & 8 \end{bmatrix} \quad (vi) \begin{bmatrix} -1 & 0 \\ 0 & -1 \end{bmatrix}$$

$$(vii) \begin{bmatrix} 3 & -4 \\ 5 & 5 \\ 4 & 3 \\ 5 & 5 \end{bmatrix}$$

4. Let $M = \begin{bmatrix} 1 & 2 \\ 3 & 4 \end{bmatrix}$

(a) Find M^{-1}

(b) Verify that $M^{-1}M = MM^{-1}$

5. If $A = \begin{bmatrix} 5 & 2 \\ 2 & 1 \end{bmatrix}$, $B = \begin{bmatrix} 4 & 2 \\ 3 & -1 \end{bmatrix}$, verify that $(AB)^{-1} = B^{-1}A^{-1}$.

6.6 SOLUTION OF SIMULTANEOUS LINEAR EQUATIONS

To determine the value of two variables, we need a pair of equations. Such a pair of equations is called a system of simultaneous linear equations.

- 1- The technique of solving a pair of simultaneous equations by
 - (a) Matrix Inversion Method
 - (b) Cramer's Rule
- 2- To apply the technique to solve some practical problems.

6.6.1 Matrix Inversion Method

$$\text{Let } a_1x + a_2y = b_1 \dots\dots\dots(i)$$

$$\text{and } a_3x + a_4y = b_2 \dots\dots\dots(ii)$$

be the two simultaneous linear equations. These equations can be written in matrix form as:

$$\begin{bmatrix} a_1x + a_2y \\ a_3x + a_4y \end{bmatrix} = \begin{bmatrix} b_1 \\ b_2 \end{bmatrix}$$

$$\text{i.e. } \begin{bmatrix} a_1 & a_2 \\ a_3 & a_4 \end{bmatrix} \begin{bmatrix} x \\ y \end{bmatrix} = \begin{bmatrix} b_1 \\ b_2 \end{bmatrix}$$

$$\text{or } AX = B \dots\dots\dots(iii)$$

$$\text{where } A = \begin{bmatrix} a_1 & a_2 \\ a_3 & a_4 \end{bmatrix}, X = \begin{bmatrix} x \\ y \end{bmatrix}, B = \begin{bmatrix} b_1 \\ b_2 \end{bmatrix}$$

To find values of the variable x and y , the equation (iii) is solved by the following method.

$$AX = B$$

If A has an inverse A^{-1} ,

$$\text{then } A^{-1}AX = A^{-1}B \quad (\because A^{-1}A = I)$$

$$IX = A^{-1}B \quad (\because IX = X)$$

$$X = \frac{\text{adj } A}{|A|} B \quad \text{provided } |A| \neq 0$$

In case A is singular ($|A| = 0$), then it is not possible to find the solution of the given equations.

EXAMPLE

Solve the following set of equations using the matrix inversion method. $3x - 4y = 7$, $5x - 7y = 12$

SOLUTION:

The given simultaneous equations may be written in matrix form as:

$$\begin{bmatrix} 3 & -4 \\ 5 & -7 \end{bmatrix} \begin{bmatrix} x \\ y \end{bmatrix} = \begin{bmatrix} 7 \\ 12 \end{bmatrix}$$

$$AX = B$$

Here $A = \begin{bmatrix} 3 & -4 \\ 5 & -7 \end{bmatrix}$, $X = \begin{bmatrix} x \\ y \end{bmatrix}$, $B = \begin{bmatrix} 7 \\ 12 \end{bmatrix}$

$$|A| = \begin{vmatrix} 3 & -4 \\ 5 & -7 \end{vmatrix} = -21 + 20 = -1$$

$$|A| = -1 \neq 0$$

As A is non-singular matrix, so the equations can be solved.

$$A^{-1} = \frac{1}{|A|} \text{adj } A = \frac{1}{-1} \begin{bmatrix} -7 & 4 \\ -5 & 3 \end{bmatrix}$$

$$A^{-1} = \begin{bmatrix} 7 & -4 \\ 5 & -3 \end{bmatrix}$$

But $X = A^{-1}B$

$$X = \begin{bmatrix} 7 & -4 \\ 5 & -3 \end{bmatrix} \begin{bmatrix} 7 \\ 12 \end{bmatrix}$$

$$X = \begin{bmatrix} 49 & -48 \\ 35 & -36 \end{bmatrix}$$

$$\begin{bmatrix} x \\ y \end{bmatrix} = \begin{bmatrix} 1 \\ -1 \end{bmatrix}$$

Thus $x = 1$ and $y = -1$.

\therefore Solution set = $\{(1, -1)\}$

Cramer's Rule:

Simultaneous linear equations can be solved by Cramer's rule. The method to solve linear equations by Cramer's rule is explained below. Consider the linear equations.

$$a_1x + a_2y = b_1$$

$$a_3x + a_4y = b_2$$

In matrix form

$$\begin{bmatrix} a_1 & a_2 \\ a_3 & a_4 \end{bmatrix} \begin{bmatrix} x \\ y \end{bmatrix} = \begin{bmatrix} b_1 \\ b_2 \end{bmatrix}$$

$$AX = B$$

$$A = \begin{bmatrix} a_1 & a_2 \\ a_3 & a_4 \end{bmatrix}, \quad X = \begin{bmatrix} x \\ y \end{bmatrix}, \quad B = \begin{bmatrix} b_1 \\ b_2 \end{bmatrix}$$

$$|A| = \begin{vmatrix} a_1 & a_2 \\ a_3 & a_4 \end{vmatrix}, \quad \text{provided } |A| \neq 0$$

$$|D_1| = \begin{vmatrix} b_1 & a_2 \\ b_2 & a_4 \end{vmatrix}$$

$$|D_2| = \begin{vmatrix} a_1 & b_1 \\ a_3 & b_2 \end{vmatrix}$$

$$\text{Now } x = \frac{|D_1|}{|A|} \quad \text{and} \quad y = \frac{|D_2|}{|A|}$$

EXAMPLE-1

Use Cramer's rule to solve the following linear equations.

$$x + 3y = 6 \quad , \quad 2x + y = 4$$

SOLUTION: $x + 3y = 6$, $2x + y = 4$ in matrix form:

$$\begin{bmatrix} 1 & 3 \\ 2 & 1 \end{bmatrix} \begin{bmatrix} x \\ y \end{bmatrix} = \begin{bmatrix} 6 \\ 4 \end{bmatrix}$$

$$AX = B$$

$$A = \begin{bmatrix} 1 & 3 \\ 2 & 1 \end{bmatrix}$$

$$|A| = \begin{vmatrix} 1 & 3 \\ 2 & 1 \end{vmatrix} = 1 - 6 = -5 \neq 0$$

Consider $|D_1| = \begin{vmatrix} 6 & 3 \\ 4 & 1 \end{vmatrix} = 6 - 12 = -6$

$$|D_2| = \begin{vmatrix} 1 & 6 \\ 2 & 4 \end{vmatrix} = 4 - 12 = -8$$

$$\therefore x = \frac{|D_1|}{|A|} = \frac{-6}{-5} \text{ and } y = \frac{|D_2|}{|A|} = \frac{-8}{-5}$$

$$x = \frac{6}{5}, \quad y = \frac{8}{5} \quad \therefore \text{Solution set} = \left\{ \left(\frac{6}{5}, \frac{8}{5} \right) \right\}$$

EXAMPLE-2

7 apples and 4 pears cost Rs. 11 while the 5 apples and 2 pears cost Rs. 7. How much each apple and pear cost ?

SOLUTION: We denote apple by 'x' and pear by 'y'

$$\text{then } 7x + 4y = 11$$

$$5x + 2y = 7$$

In matrix form

$$\begin{bmatrix} 7 & 4 \\ 5 & 2 \end{bmatrix} \begin{bmatrix} x \\ y \end{bmatrix} = \begin{bmatrix} 11 \\ 7 \end{bmatrix}$$

$$AX = B$$

$$|A| = \begin{vmatrix} 7 & 4 \\ 5 & 2 \end{vmatrix} = 14 - 20 = -6 \neq 0$$

$$|D_1| = \begin{vmatrix} 11 & 4 \\ 7 & 2 \end{vmatrix} = 22 - 28 = -6$$

$$|D_2| = \begin{vmatrix} 7 & 11 \\ 5 & 7 \end{vmatrix} = 49 - 55 = -6$$

$$x = \frac{|D_1|}{|A|} = \frac{-6}{-6} = 1, \text{ one apple costs Rs 1.}$$

$$y = \frac{|D_2|}{|A|} = \frac{-6}{-6} = 1, \text{ one pear costs Rs 1.}$$

EXAMPLE-3

Find two numbers whose sum is 67 and difference is 3.

SOLUTION:

Let x and y be two numbers and also $x > y$

$$x + y = 67 \quad \text{_____ (i)}$$

$$x - y = 3 \quad \text{_____ (ii)}$$

In matrix form:

$$\begin{bmatrix} 1 & 1 \\ 1 & -1 \end{bmatrix} \begin{bmatrix} x \\ y \end{bmatrix} = \begin{bmatrix} 67 \\ 3 \end{bmatrix}$$

$$AX = B$$

$$|A| = \begin{vmatrix} 1 & 1 \\ 1 & -1 \end{vmatrix} = -1 - 1 = -2 \neq 0$$

$$|D_1| = \begin{vmatrix} 67 & 1 \\ 3 & -1 \end{vmatrix} = -67 - 3 = -70$$

$$|D_2| = \begin{vmatrix} 1 & 67 \\ 1 & 3 \end{vmatrix} = 3 - 67 = -64$$

$$x = \frac{|D_1|}{|A|} = \frac{-70}{-2} = 35$$

$$y = \frac{|D_2|}{|A|} = \frac{-64}{-2} = 32$$

$$x = 35 \quad y = 32$$

\therefore the required numbers are 35 and 32.

EXAMPLE-4

A belt and a wallet cost Rs. 42, while 7 belts and 4 wallets cost Rs. 213. Calculate the cost of each item.

SOLUTION:

Let the cost of a belt and wallet is denoted by x and y respectively

$$x + y = 42 \quad \text{_____ (i)}$$

$$7x + 4y = 213 \quad \text{_____ (ii)}$$

In matrix form:

$$\begin{bmatrix} 1 & 1 \\ 7 & 4 \end{bmatrix} \begin{bmatrix} x \\ y \end{bmatrix} = \begin{bmatrix} 42 \\ 213 \end{bmatrix}$$

$$AX = B$$

$$|A| = \begin{vmatrix} 1 & 1 \\ 7 & 4 \end{vmatrix} = 4 - 7 = -3 \neq 0$$

$$\text{adj } A = \begin{bmatrix} 4 & -1 \\ -7 & 1 \end{bmatrix}$$

$$AX = B$$

$$X = A^{-1}B$$

$$X = \left(\frac{\text{adj } A}{|A|} \right) B$$

$$= \frac{1}{-3} \begin{bmatrix} 4 & -1 \\ -7 & 1 \end{bmatrix} \begin{bmatrix} 42 \\ 213 \end{bmatrix}$$

$$\begin{bmatrix} x \\ y \end{bmatrix} = -\frac{1}{3} \begin{bmatrix} 168 - 213 \\ -294 + 213 \end{bmatrix}$$

$$\begin{bmatrix} x \\ y \end{bmatrix} = -\frac{1}{3} \begin{bmatrix} -45 \\ -81 \end{bmatrix}$$

$$\begin{bmatrix} x \\ y \end{bmatrix} = \begin{bmatrix} 15 \\ 27 \end{bmatrix}$$

$$x = 15, \quad y = 27$$

\therefore the cost of a belt and wallet is Rs. 15 and Rs. 27 respectively.

EXERCISE - 6.6

- 1- Write the equation $2x + ky = 7$ and $4x - 9y = 4$ in matrix form. Also find the value of k if the matrix of the coefficients is singular.
2. Solve the simultaneous equations by the matrix inversion method where possible. Where there is no solution, explain why this is so.

(i) $2x - 5y = 1$

$3x - 7y = 2$

(ii) $3x + 2y = 10$

$2y - 3x = -4$

(iii) $4x + 5y = 0$

$2x + 5y = 1$

(iv) $5x + 6y = 25$

$3x + 4y = 17$

(v) $x + y = 2$

$y = 2 + x$

(vi) $\frac{x}{2} + \frac{y}{3} = 1$

$-4x + y = 14$

3. Solve, using matrix inversion method

$3x - y = 10$

$2x + 3y = 3$

4. Use Cramer's rule to solve the simultaneous equations. Give the reason where solution is not possible.

(i) $x + 2y = 3$

$x + 3y = 5$

(ii) $2x + y = 1$

$5x + 3y = 2$

(iii) $x + 3y = 1$

$2x + 8y = 0$

(iv) $-2x + 6y = 5$

$x - 3y = -7$

(v) $x - 3y = 5$

$2x - 5y = 9$

(vi) $5x + 2y = 13$

$2x + 5y = 17$

5. Write the following matrices in the form of linear equations.

(i) $\begin{bmatrix} 2 & -1 \\ 5 & 2 \end{bmatrix} \begin{bmatrix} x \\ y \end{bmatrix} = \begin{bmatrix} 2 \\ 4 \end{bmatrix}$

(ii) $\begin{bmatrix} -5 & 2 \\ 2 & -3 \end{bmatrix} \begin{bmatrix} x \\ y \end{bmatrix} = \begin{bmatrix} 2 \\ -1 \end{bmatrix}$

(iii) $\begin{bmatrix} -4 & 1 \\ 5 & 4 \end{bmatrix} \begin{bmatrix} x \\ y \end{bmatrix} = \begin{bmatrix} 1 \\ -1 \end{bmatrix}$

(iv) $\begin{bmatrix} 0.8 & -0.6 \\ 0.6 & 0.8 \end{bmatrix} \begin{bmatrix} x \\ y \end{bmatrix} = \begin{bmatrix} 1 \\ 2 \end{bmatrix}$

Review Exercise-6

Circle the Correct Answer.

The number of rows and columns in a matrix determine its:

- (a) order
(b) rows
(c) columns
(d) determinant

A matrix consisting of one row is called a:

- (a) row matrix
(b) column matrix
(c) identity matrix
(d) scalar matrix

Two matrices are conformable for addition, if they are of

- (a) the same order
(b) the different order
(c) the order 2×2
(d) order 3×3

In a square matrix the number of rows and columns is:

- (a) 3×2
(b) 2×1
(c) 2×2
(d) 3×3

Two matrices are conformable for multiplication, if they are of

- (a) the same order and equal corresponding elements
(b) diagonal matrices
(c) the same order and unequal corresponding elements
(d) unequal matrices

Two matrices are conformable for multiplication, if they are of

9. In matrices $(AB)' = ?$

(a) A

(b) B

(c) $B' A'$

(d) $A' B'$

10. In matrices $(AB)^{-1} = ?$

(a) A^{-1}

(b) B^{-1}

(c) $B^{-1} A^{-1}$

(d) $A^{-1} B^{-1}$

II- Fill in the blanks.

1. The number of rows and columns in a matrix determine its _____.
2. A matrix consisting of one row only is called a _____.
3. Two matrices are conformable for addition, if they are of the _____.
4. In a square matrix the number of rows and columns is _____.
5. Two matrices of the same order are _____ if their corresponding elements are same.
6. In a unit matrix the diagonal elements are _____.
7. $(AB)C = A(BC)$, where A, B and C are matrices is called _____ under multiplication.
8. If $A' = -A$, then the matrix A is said to be _____.
9. In matrices $(AB)' =$ _____.
10. In matrices $(AB)^{-1} =$ _____.

SUMMARY

Matrix: A rectangular array of numbers, enclosed by a pair of brackets and subject to certain rules is called a matrix.

Order of a matrix: The number of rows and columns in a matrix determine its order.

Row matrix: A matrix consisting of one row only is called a row matrix.

Column matrix: A matrix consisting of one column only is called a column matrix.

Square matrix: In a square matrix, the number of rows and columns are equal.

Rectangular matrix: In a rectangular matrix, number of rows and columns are not same.

Zero or null matrix: If all elements in a matrix are zero, the matrix is called a zero or null matrix.

Unit or Identity matrix: In an identity matrix, the diagonal elements are unity and off diagonal elements are all zero.

Transpose of a matrix: A matrix obtained by interchanging rows into columns is called transpose of a matrix.

Symmetric matrix: A matrix A is said to be symmetric, if $A' = A$.

Skew-Symmetric matrix : A matrix A is said to be skew-symmetric, if $A' = -A$.

Determinant: A real number associated with a square matrix is called determinant of a square matrix.

Singular matrix: If the determinant of a square matrix is zero, it is called a singular matrix, otherwise non-singular matrix.

Adjoint of a square matrix of order 2×2

In the adjoint of a square matrix of order 2×2 the diagonal elements are interchanged, whereas the sign of other diagonal elements are changed.

Multiplicative inverse of a square matrix,

A matrix B is said to be multiplicative inverse of 'A', if $AB = I$.

UNIT

7

FUNDAMENTALS OF GEOMETRY

- ▶ **Properties of Angles**
- ▶ **Congruent and Similar Figures**
- ▶ **Quadrilaterals**
- ▶ **Parallel Lines**
- ▶ **Congruent Triangles**
- ▶ **Circle**

After completion of this unit, the students will be able to:

- ▶ define adjacent, complementary and supplementary angles.
- ▶ define vertically-opposite angles.
- ▶ calculate unknown angles involving adjacent angles, complementary angles, supplementary angles and vertically opposite angles.
- ▶ calculate unknown angle of a triangle.
- ▶ define parallel lines.
- ▶ demonstrate through figures the following properties of parallel lines.
 - Two lines which are parallel to the same given line are parallel to each other.
 - If three parallel lines are intersected by two transversals in such a way that the two intercepts on one transversal are equal to each other, the two intercepts on the second transversal are also equal.
 - A line through the midpoint of a side of a triangle parallel to another side bisects the third side (an application of above property).
- ▶ draw a transversal to intersect two parallel lines and demonstrate corresponding angles, alternate-interior angles, vertically-opposite angles and interior angles on the same side of transversal.
- ▶ describe the following relations between the pairs of angles when a transversal intersects two parallel lines:
 - Pairs of corresponding angles are equal.
 - Pairs of alternate interior angles are equal.
 - Pair of interior angles on the same side of transversal is supplementary, and demonstrate them through figures.
- ▶ identify congruent and similar figures.
- ▶ recognize the symbol of congruency.
- ▶ apply the properties for two figures to be congruent or similar.
- ▶ apply following properties for congruency between two triangles.
 - $SSS \cong SSS$, • $SAS \cong SAS$, • $ASA \cong ASA$, • $RHS \cong RHS$.
- ▶ demonstrate the following properties of a square.
 - The four sides of a square are equal.
 - The four angles of a square are right angles.
 - Diagonals of a square bisect each other and are equal.
- ▶ demonstrate the following properties of a rectangle.
 - Opposite sides of a rectangle are equal.
 - The four angles of a rectangle are right angles.
 - Diagonals of a rectangle bisect each other.
- ▶ demonstrate the following properties of a parallelogram.
 - Opposite side of a parallelogram are equal.
 - Opposite angles of a parallelogram are equal.
 - Diagonals of a parallelogram bisect each other.
- ▶ describe a circle and its centre, radius, diameter, chord, arc, major and minor arcs, semicircle and segment of the circle.
- ▶ describe the terms; sector and secant of circle, concyclic points, tangent to a circle and concentric circles.
- ▶ demonstrate the following properties:
 - The angle in a semicircle is a right angle.
 - The angles in the same segment of a circle are equal.
 - The central angle of a minor arc of a circle, is double that of the angle subtended by the corresponding major arc.
- ▶ apply the above properties in different geometrical figures.

7.1 PROPERTIES OF ANGLES

Before going to study the properties of angles, let us revise what we have learned in our previous classes about angles.

Angle:-

An **angle** is the union of two rays with the common end point. The rays are called the arms and their common end point, is called **vertex** of the angle.

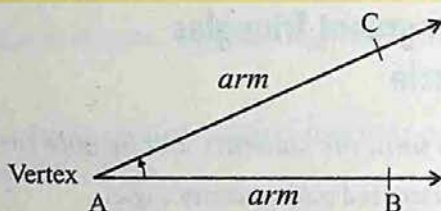

An angle may be named as:

- 1- By naming the vertex, that is, $\angle A$.
- 2- By naming the vertex and another point on each arm. In this case, the letter at the vertex is placed between the other two letters, thus $\angle BAC$ or $\angle CAB$.

Straight Angle:-

A straight angle contains 180° and is equal to two right angles. The arms of a straight angle extend in opposite directions, forming a straight line.

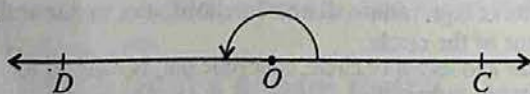

Right Angle:-

The given figure is of a right angle.

A right angle contains 90° .

$m\angle AOB = 90^\circ$

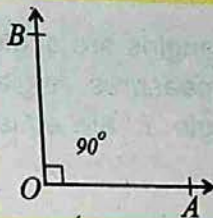

Acute Angle:-

An acute angle contains more than 0° and less than 90° .

Angle 'O' is an acute angle.

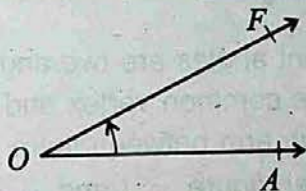

Obtuse Angle:-

An obtuse angle contains more than 90° and less than 180° . Angle Q is an obtuse angle.

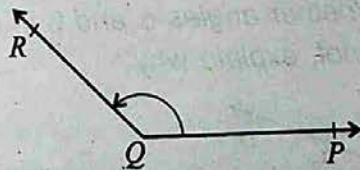

Reflex Angle:-

A reflex angle contains more than 180° and less than 360° . Angle M is a reflex angle.

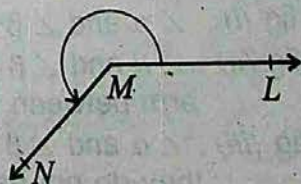

Equal Angles :-

Equal angles are angles with equal measures. Angle 'O' and angle 'L' are equal angles.

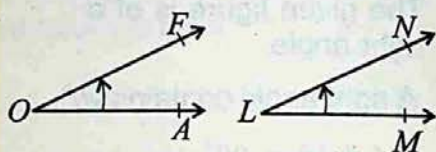
**7.1.1 Adjacent, Complementary And Supplementary Angles****Adjacent Angles :-**

Adjacent angles are two angles with the common vertex and a common arm between them. In the given figure, $\angle 1$ and $\angle 2$ are called adjacent angles with common vertex B and common arm BD .

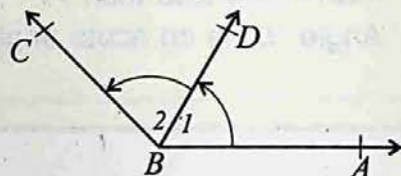
**EXAMPLE**

Whether angles α and β in the following figures are adjacent? If not, explain why?

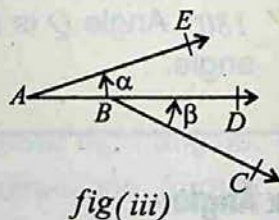
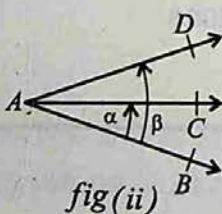
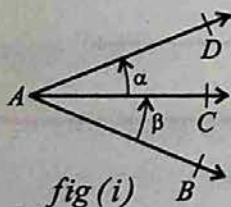
**SOLUTION:**

In fig (i), $\angle \alpha$ and $\angle \beta$ are adjacent angles.

In fig (ii), $\angle \alpha$ and $\angle \beta$ are not adjacent angles because no arm between them is common.

In fig (iii), $\angle \alpha$ and $\angle \beta$ are not adjacent angles because they do not have a common vertex.

Complementary Angles :-

Complementary angles are two angles whose sum is 90° . If the sum of two angles is a right angle i.e. 90° (they need not to be adjacent), each angle is called the complement of the other.

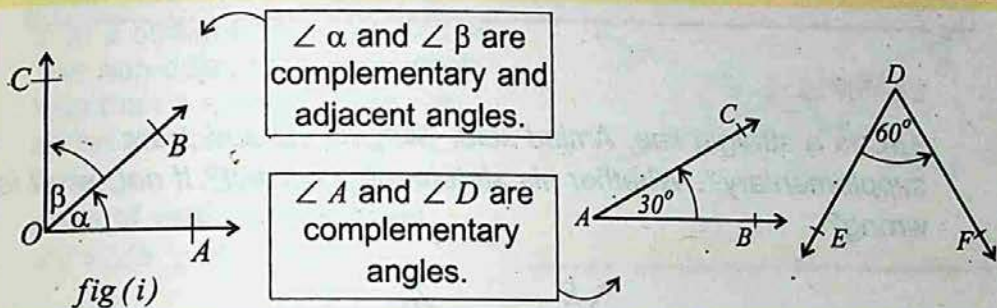

Note:

If two angles are adjacent and complementary, then their exterior sides are perpendicular to each other and vice-versa. In figure (i), $\angle \alpha$ and $\angle \beta$ are adjacent and complementary hence $\overrightarrow{OC} \perp \overrightarrow{OA}$.

Supplementary Angles :-

Supplementary angles are two angles whose sum is 180° . If the sum of two angles is 180° , then each angle is called the supplement of the other.

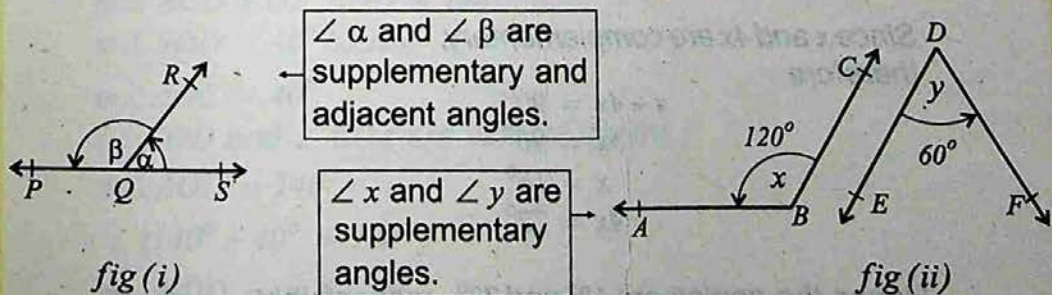

Note:

If two angles are adjacent and supplementary, then their exterior arms is a straight line and vice-versa. In figure (i) on previous page $\angle \alpha$ and $\angle \beta$ are adjacent and supplementary angles, thus PQS is a straight line.

EXAMPLE-1

ABC is a straight line. Amjad said, "Angles 1, 2 and 3 are supplementary". Whether his statement is correct? If not, what is wrong?

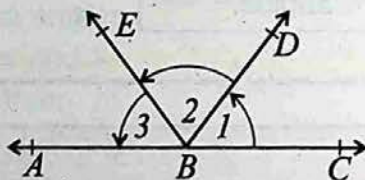
**SOLUTION:**

No, because, supplementary angles are two angles, not three.

EXAMPLE-2

If two angles are complementary and the larger angle is four times bigger than smaller angle, how many degrees are there in each angle?

SOLUTION:

Let x represents the number of degrees in the smaller angle.

Then $4x$ represents the number of degrees in the larger angle.

Since x and $4x$ are complementary, therefore

$$x + 4x = 90^\circ$$

$$5x = 90^\circ$$

$$x = 18^\circ$$

$$4x = 72^\circ$$

Hence the angles are 18° and 72° , respectively.

7.1.2 Vertical Angles

Vertical angles are two non-adjacent angles, each less than a straight angle, formed by two intersecting lines.

Draw two lines intersecting at a point. How many angles less than a straight angle are formed? The non-adjacent angles, each less than a straight angle, are called vertical angles. In the figure $\angle a$, $\angle b$; and $\angle c$, $\angle d$ are pairs of vertical angles and $\angle a = \angle b$, $\angle c = \angle d$

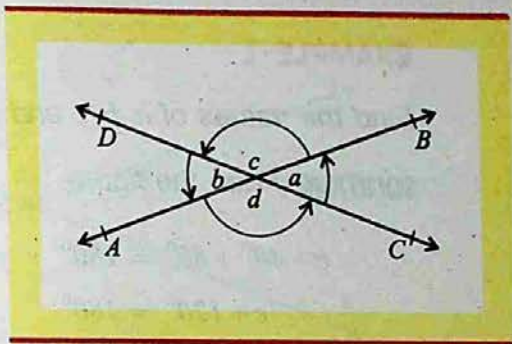

EXAMPLE

In the figure, two straight lines AB and CD , are intersecting at a point O forming $m\angle BOD = 40^\circ$.

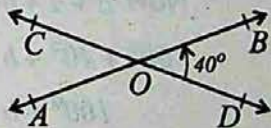

What is the measure of $\angle AOD$ and $\angle AOC$?

What can you say about $\angle BOD$ and $\angle COA$?

SOLUTION :

Since $\angle AOB$ is a straight line and equal to 180° , therefore,

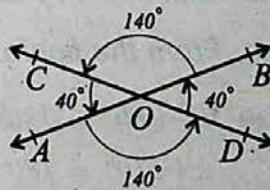

$$m\angle AOD + m\angle BOD = 180^\circ$$

$$m\angle BOD = 40^\circ \text{ (Given)}$$

$$m\angle AOC = 40^\circ$$

($\angle BOD$ and $\angle COA$ are vertical angles.)

$$m\angle AOD = 140^\circ$$

$$\therefore (140^\circ + 40^\circ = 180^\circ)$$

$$m\angle BOD = m\angle COA$$

7.1.3 Calculate Unknown Angles

Let us consider the following example to calculate the unknown angles involving adjacent, complementary, supplementary and vertically-opposite angles.

EXAMPLE-1

Find the values of a , b , c and d in the given figure.

SOLUTION: From the figure.

$$c + 40^\circ + 80^\circ = 180^\circ$$

$$c + 120^\circ = 180^\circ$$

$$c = 180^\circ - 120^\circ$$

$$c = 60^\circ$$

Therefore $c = a = 60^\circ$ (vertically-opposite angles)

$$\text{Now } a + d + b = 180^\circ$$

$$60^\circ + 40^\circ + b = 180^\circ$$

$$100^\circ + b = 180^\circ$$

$$b = 80^\circ$$

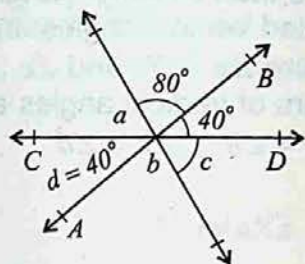

EXAMPLE-2

Find the values of x , y and z in the given figure.

SOLUTION: From the figure.

$$x + 50^\circ + 60^\circ = 180^\circ$$

$$x + 110^\circ = 180^\circ$$

$$x = 180^\circ - 110^\circ$$

$$x = 70^\circ$$

But $x = y$ (vertically-opposite angles)

$$y = 70^\circ$$

$$\text{Now } y + z = 180^\circ$$

$$70^\circ + z = 180^\circ$$

$$z = 110^\circ$$

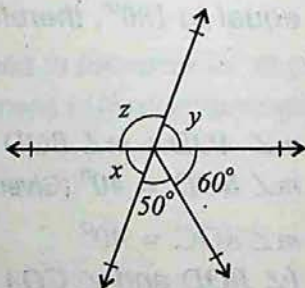

THEOREM

If two straight lines intersect each other, then the vertical angles are equal.

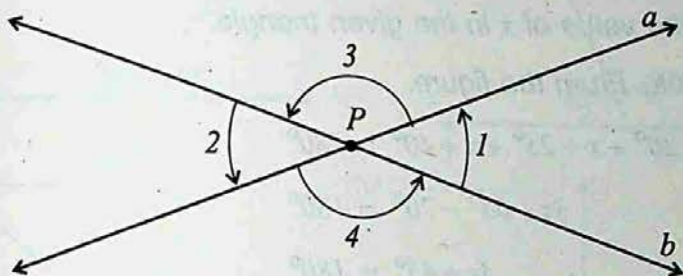

The straight lines a and b are intersecting at the point P and forming the pairs of vertical angles 1 and 2 , 3 and 4 .

$$\angle 1 = \angle 2 \text{ and } \angle 3 = \angle 4$$

If $\angle 1$ and $\angle 2$ are supplements of the same angle, then they will be equal.

Remember that:

- If two angles are complements of the same angle, they are equal.
- If two angles are complements of equal angles, they are equal.
- If two angles are supplements of the same angle, they are equal.
- If two straight lines intersect each other, then the vertical angles are equal.

7.1.4 Calculate Unknown Angles of a Triangle

To calculate unknown angles of a triangle, we follow the equation for the angles of a triangle and then solve it.

EXAMPLE-1

Find the value of x in the given triangle.

SOLUTION: From the figure.

$$x - 20^\circ + x + 25^\circ + x + 40^\circ = 180^\circ$$

$$3x + 65^\circ - 20^\circ = 180^\circ$$

$$3x + 45^\circ = 180^\circ$$

$$3x = 135^\circ \Rightarrow x = 45^\circ$$

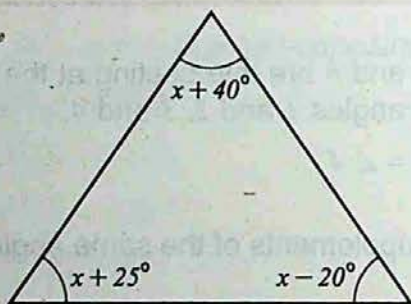

Thus the three angles are: $x - 20^\circ = 45^\circ - 20^\circ = 25^\circ$

$$x + 25^\circ = 45^\circ + 25^\circ = 70^\circ$$

$$x + 40^\circ = 45^\circ + 40^\circ = 85^\circ$$

EXAMPLE-2

Find the value of x in the given triangle.

SOLUTION: We know that

$$x + 45^\circ + 90^\circ = 180^\circ$$

$$x + 135^\circ = 180^\circ$$

$$x = 180^\circ - 135^\circ$$

$$x = 45^\circ$$

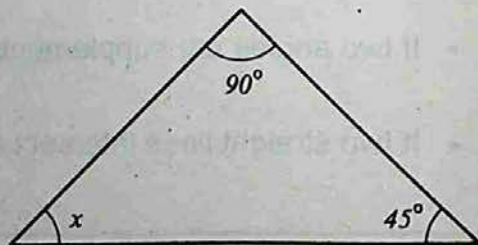

EXERCISE - 7.1

- 1- Write down the angles marked with letters. Write whether the angles are complimentary or supplementary?

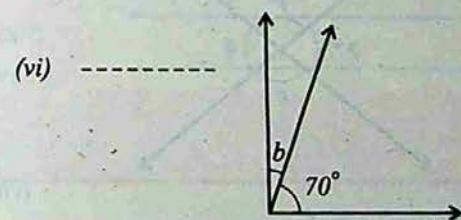
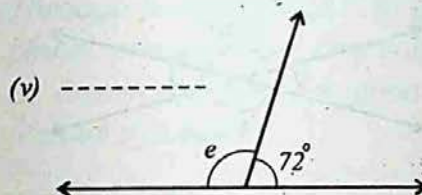
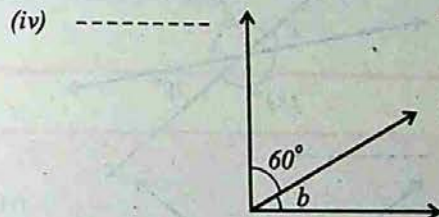
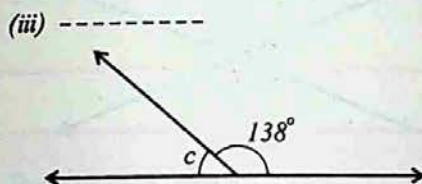
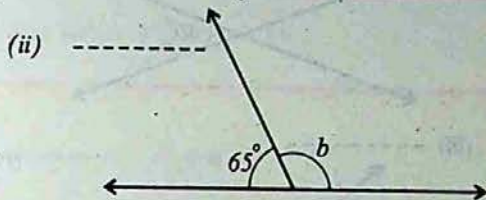
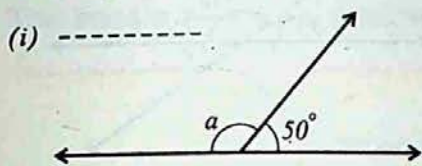

- 2- Two angles are supplementary and the greater exceeds the smaller by 30° . How many degrees are there in each angle?
- 3- If 40° is added to an angle, the resulting angle is equal to the supplement of the original angle. Find the original angle?
- 4- The sum of two angles is 100° , and the difference between their supplements is 100° . Find the angles.
- 5- The sum of two angles is 100° , the supplement of the first angle exceeds the supplement of the second angle by 40° . Find the angles.
- 6- Write the equation for the given triangle and solve it.

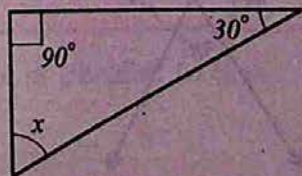

7- Write down the angles marked with letters.

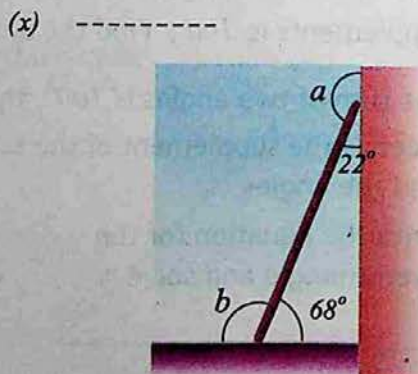
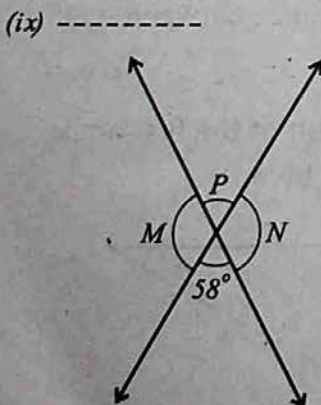
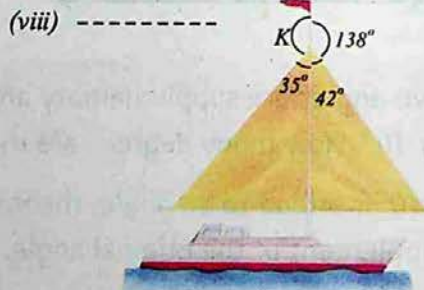
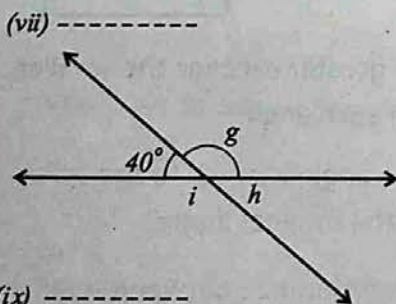
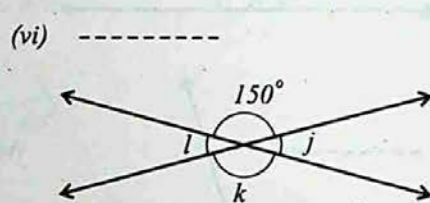
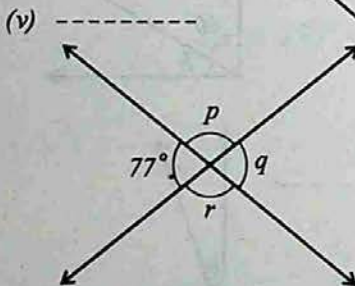
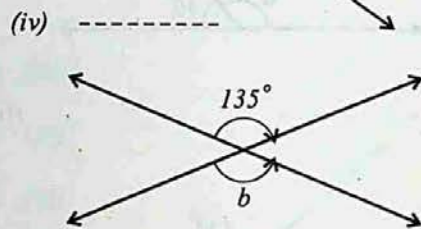
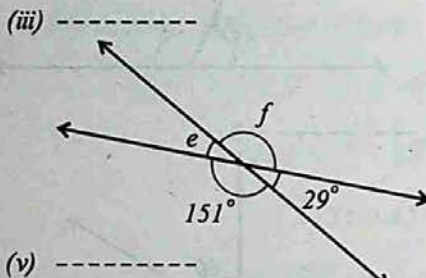
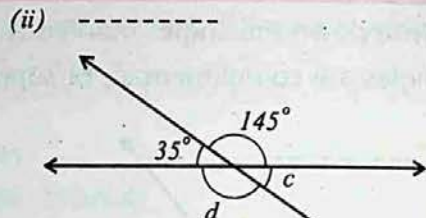
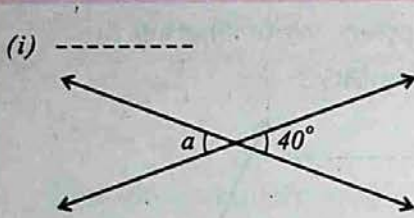

7.2 PARALLEL LINES

Parallel lines are two straight lines in the same plane which never meet.

The lines a and b are parallel, we write $a \parallel b$.



Remember that:

Through a given point P in a plane, one and only one line can be drawn parallel to a given line l .
(Parallel postulate)

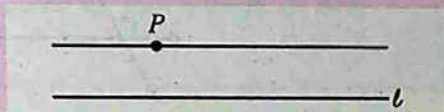

7.2.1 Properties Of Parallel Lines

a) Two lines parallel to a third line are parallel to each other.

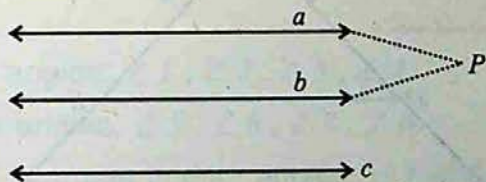

Line a is parallel to line c , line b is parallel to line c . Then a is parallel to b .

If $a \parallel c$, $b \parallel c$, then $a \parallel b$.

- b) If three parallel lines are intercepted by two transversals in such a way that the two intercepts on one transversal are equal to each other, the two intercepts on the second transversal are also equal.

i.e. if $\overline{AD} \parallel \overline{BE} \parallel \overline{CF}$

\overline{AC} and \overline{DF} are transversals,

then $\overline{AB} \cong \overline{BC}$

$\overline{DE} \cong \overline{EF}$

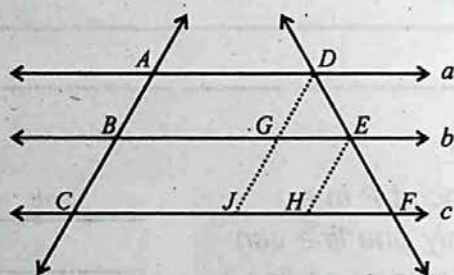

- c) If a line bisects one side of a triangle and is parallel to a second side, then it bisects the third side.

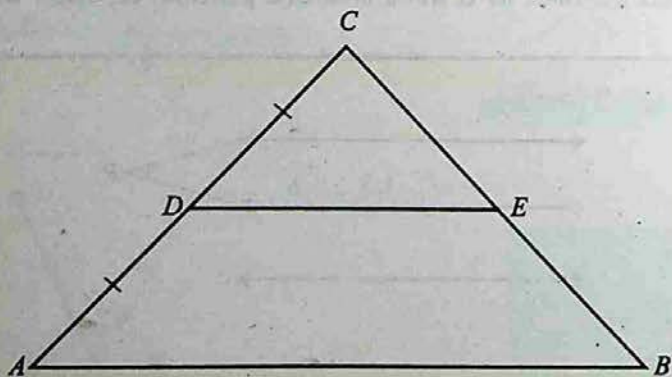

i.e. if $\triangle ABC$ with $\overline{CD} \cong \overline{DA}$, $\overline{DE} \parallel \overline{AB}$

then $\overline{CE} \cong \overline{EB}$

7.2.2 Transversal

A transversal is a line that intersects two lines in different points.

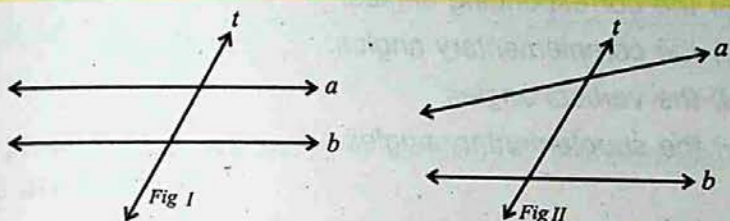

Note:

- 1- In the Fig I and II a transversal "t" intersects (or cuts) two lines a and b.
- 2- The transversal can intersect three or more lines at one point of each line.

If a transversal "t" intersects two parallel lines a and b, the angles formed are identified as follows:

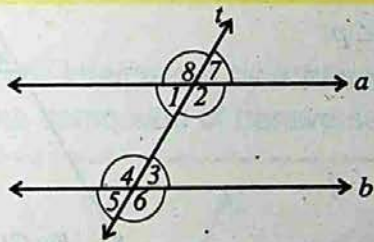

- 1- Four interior angles: $\angle 1, \angle 2, \angle 3, \angle 4$.
- 2- Four exterior angles: $\angle 5, \angle 6, \angle 7, \angle 8$.
- 3- Two pairs of alternate interior angles: $\angle 1$ and $\angle 3$; $\angle 2$ and $\angle 4$.
- 4- Two pairs of alternate exterior angles: $\angle 5$ and $\angle 7$; $\angle 6$ and $\angle 8$.
- 5- Two pairs of interior angles on the same side of the transversal: $\angle 2$ and $\angle 3$; $\angle 1$ and $\angle 4$.
- 6- Four pairs of corresponding angles: $\angle 3$ and $\angle 7$; $\angle 4$ and $\angle 8$; $\angle 2$ and $\angle 6$; $\angle 1$ and $\angle 5$.

EXAMPLE

Look at the following figures and answer the following questions:

- the alternate interior angles.
- the corresponding angles.
- the complementary angles.
- the vertical angles.
- the supplementary angles.

SOLUTION:

In Fig 1

- $\angle 1, \angle 2$
- $\angle 1, \angle 4$
- none
- $\angle 3, \angle 5; \angle 2, \angle 4$
- $\angle 3, \angle 2; \angle 2, \angle 5;$
 $\angle 5, \angle 4; \angle 4, \angle 3$

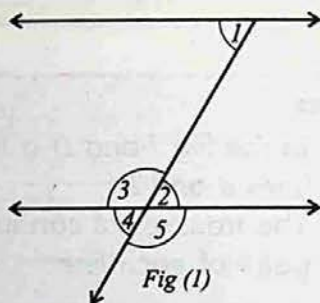

In Fig 2

- $\angle m, \angle r; \angle r, \angle p$
- none
- none
- none
- $\angle n, \angle r; \angle p, \angle q$

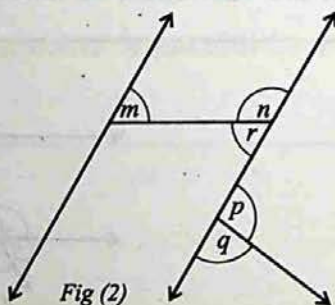

In Fig 3

- $\angle 1, \angle 2; \angle 3, \angle 6$
- $\angle 1, \angle 4; \angle 5, \angle 6$
- none
- $\angle 2, \angle 4; \angle 3, \angle 5$
- $\angle 2, \angle 3; \angle 3, \angle 4;$
 $\angle 4, \angle 5; \angle 2, \angle 5$

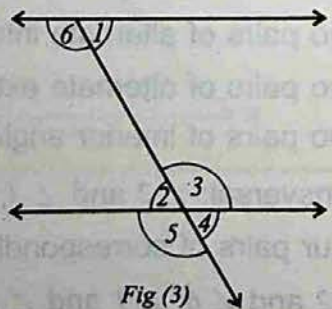

7.2.3 Relation Between The Pairs of Angles

If two parallel lines are cut by a transversal, the corresponding angles are equal.

$$[\angle 1 = \angle 2, \angle 2 = \angle 3, \\ \therefore \angle 1 = \angle 3]$$

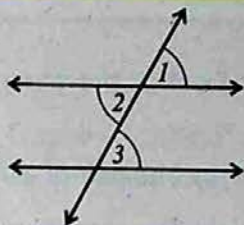

- d) If two parallel lines are cut by a transversal, the alternate interior angles are equal.

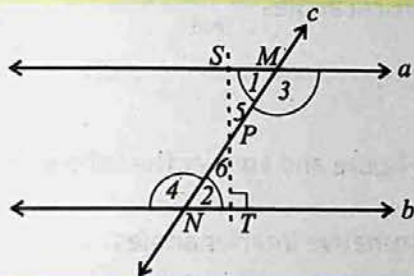

$a \parallel b$, lines a and b are cut by the transversal c at points M and N to form the pairs of alternate interior angles

$(\angle 1, \angle 2)$ and $(\angle 3, \angle 4)$

$$\angle 1 = \angle 2, \angle 3 = \angle 4$$

- e) If two parallel lines are intercepted by a transversal, then pairs of interior angles on the same side of transversal are supplementary.

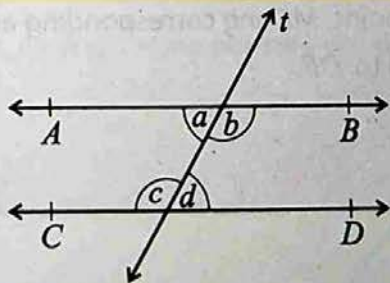

$AB \parallel CD$, lines are cut by the transversal t , angles a, b, c and d are formed.

$$m\angle b + m\angle d = 180^\circ$$

$$m\angle a + m\angle c = 180^\circ$$

EXERCISE - 7.2

1. Look at the given figure and answer the following questions.

- The pair of alternative interior angles
- The pair of corresponding angles
- The pair of complementary angles
- The pair of supplementary angles
- The pair of vertical angles

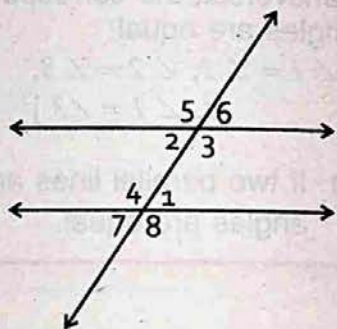

2. Look at the given figure and answer the following questions.

- The pair of alternative interior angles
- The pair of corresponding angles
- The pair of complementary angles
- The pair of supplementary angles
- The pair of vertical angles

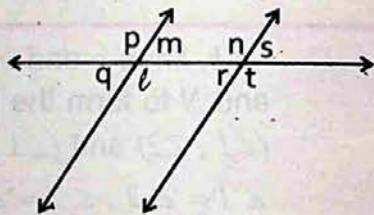

3. Take a point 'X' outside a line \overline{DE} . Draw a line through 'X' which cuts \overline{DE} at some point. Making corresponding angles congruent draw a line parallel to \overline{DE} .

7.3 CONGRUENT AND SIMILAR FIGURES

7.3.1 Congruent Figures

The word congruent comes from Latin meaning "together agree". Two geometrical figures which have the same size and shape are congruent.

One figure is congruent to the other. The symbol for congruent is \cong . Thus two segments are congruent when they have the same size.

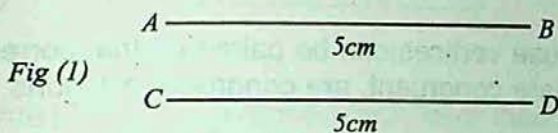

$$\overline{AB} \cong \overline{CD}$$

All segments, being straight, have the same shape. They have the same size if they have the same length.

In the above Fig (1) $m\overline{AB} = m\overline{CD} = 5\text{cm}$. Therefore \overline{AB} and \overline{CD} are of same size.

- ▶ Two segments which have the same length are congruent segments.

In the Fig (1) $\overline{AB} \cong \overline{CD}$

- ▶ Two angles which have the same measure are congruent angles.

$$\angle ABC \cong \angle DEF$$

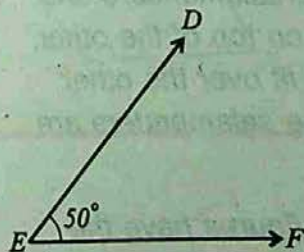
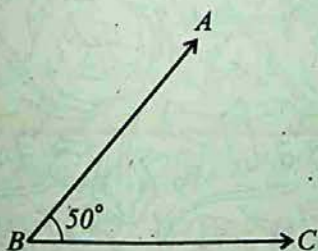

- *Triangles, all of whose corresponding parts congruent are congruent triangles.*

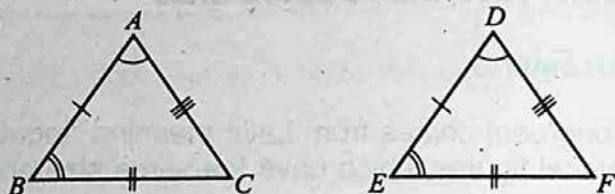

$$\overline{AB} \cong \overline{DE}, \overline{BC} \cong \overline{EF}, \overline{AC} \cong \overline{DF}$$

and $\angle A = \angle D, \angle B = \angle E, \angle C = \angle F$

$$\triangle ABC \cong \triangle DEF$$

Two polygons whose vertices can be paired so that corresponding angles and sides are congruent, are congruent polygons.

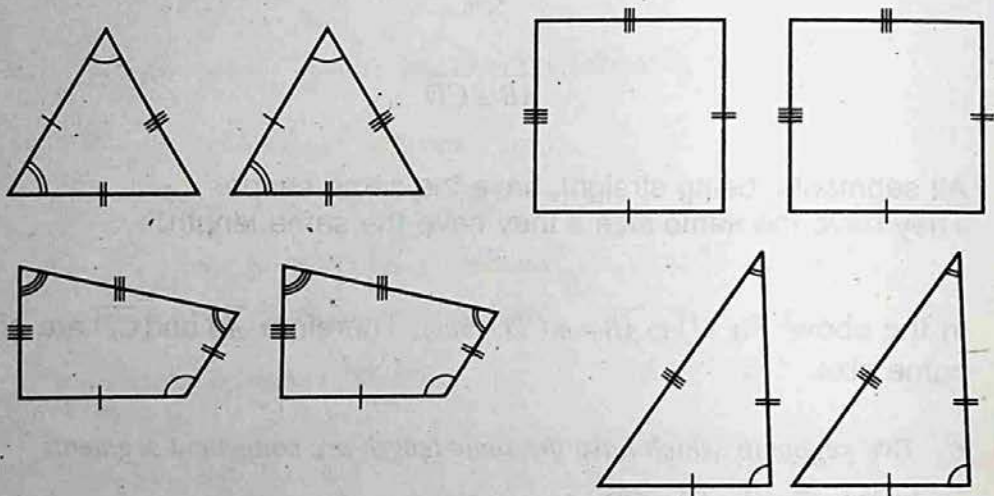

The drawing is by the artist M.C. Escher. Notice that if you cut out two salamanders and place one on top of the other, one would fit over the other exactly. The salamanders are congruent.

Congruent figures have the same size and shape.

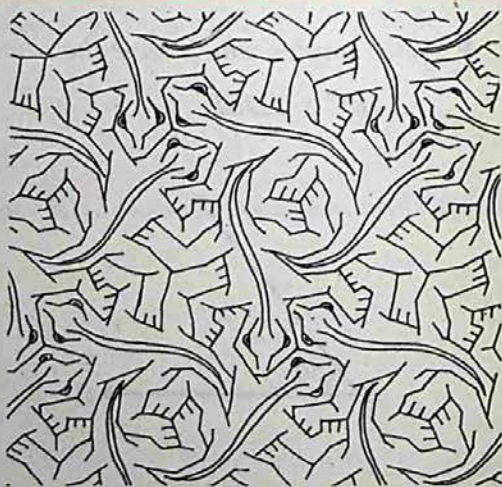

Similar Figures

In the polygons below, the members of each pair are similar to each other.

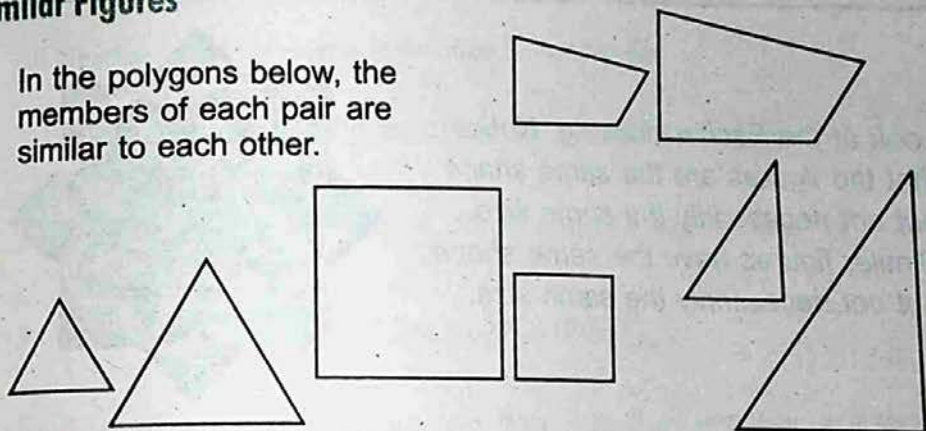

Similar polygons are polygons which have their corresponding angles equal and their corresponding sides in a proportion. Remember that both conditions must exist.

Since a definition is reversible, it follows that, if two polygons are similar, their corresponding angles are equal and their corresponding sides are in proportion.

Similarity like congruence represents a special kind of correspondence.

If polygon P_1 is similar to polygon P_2 (written $P_1 \sim P_2$)

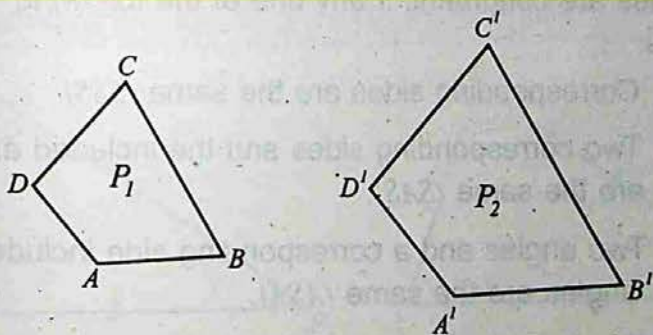

$$1- \angle A = \angle A', \angle B = \angle B' \\ \angle C = \angle C', \angle D = \angle D'$$

$$2- \frac{AB}{A'B'} = \frac{BC}{B'C'} = \frac{CD}{C'D'} = \frac{DA}{D'A'}$$

Look at the Escher drawing. Notice that the figures are the same shape but not necessarily the same size. Similar figures have the same shape but not necessarily the same size.

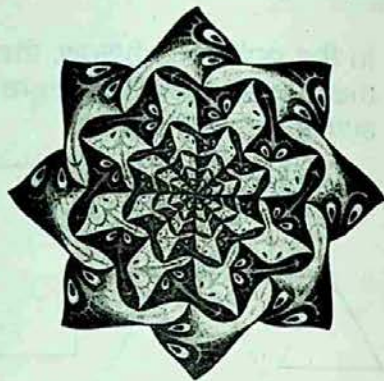

7.3.2 Symbol (\cong)

Two geometrical figures which have the same size and shape are called congruent figures. The symbol for congruency is \cong .

7.3.3 Properties of Congruency

1. Congruent figures are identical in all respects i.e. they have the same shape and the same size.
2. Triangles are congruent, if any one of the following applies:
 - (a) Corresponding sides are the same (*SSS*).
 - (b) Two corresponding sides and the included angle are the same (*SAS*).
 - (c) Two angles and a corresponding side included angles are the same (*ASA*).
 - (d) The hypotenuse and one pair of the other corresponding sides are the same in a right angle triangle (*RHS*).
3. Circles which have congruent radii are congruent.
4. Two angles which have the same measure are congruent.

EXERCISE - 7.3

Tell Whether or not the Figures in Question 1-3 are Similar:

- All squares; all rectangles; all regular hexagons.
- Two rectangles with sides 8, 12, 10 and 15.
- Two rhombuses with angles of 55° and 125° .
- The sides of a polygon are 5cm, 6cm, 7cm, 8cm, and 9cm. In a similar polygon the sides corresponding to 6cm is 12cm. Find the other sides of the second polygon.
- The sides of a quadrilateral are 2cm, 4cm, 6cm, and 7cm. The longest side of a similar quadrilateral is 21cm. Find the other sides.
- The sides of a polygon are 5cm, 2cm, 7cm, 3cm, 4cm. Find the sides of a similar polygon whose side corresponding to 2cm is 6cm. What is the ratio of the perimeters of these two polygons?
- What are the congruent pairs of corresponding sides and corresponding angles?

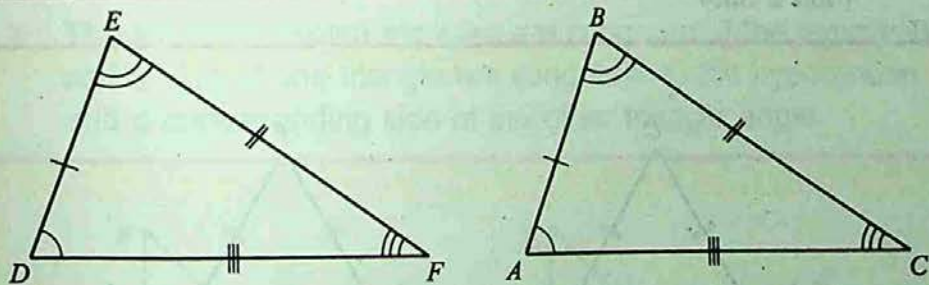

- Are all similar figures congruent? Explain why?
- Are all congruent figures similar? Explain why?

7.4 CONGRUENT TRIANGLES

Congruent triangles are two triangles whose vertices can be paired so that corresponding parts (angles and sides) are equal in correspondence.

In the figure given below, symbolically, $\Delta PQR \cong \Delta KLM$ means triangles PQR is congruent to triangle KLM .

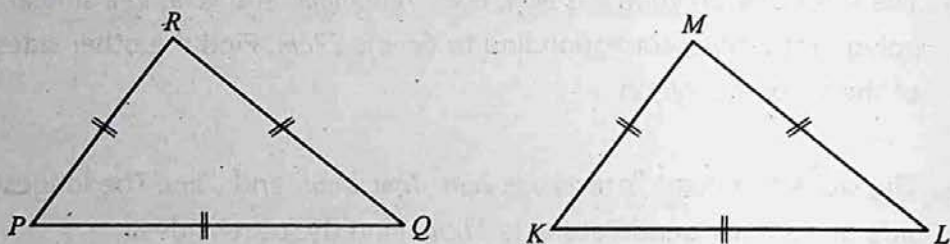

Properties of Congruency Between Two Triangles:-

- ▶ Two triangles are congruent if the corresponding sides of the first are equal respectively, to the sides of the second triangle ($SSS \cong SSS$)

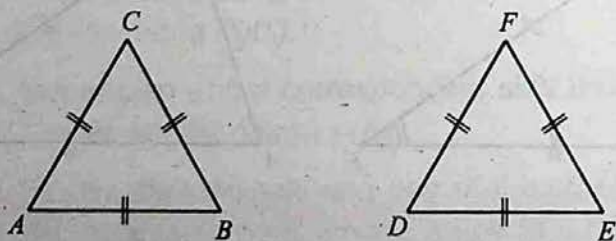

In the figure ΔABC and ΔDEF are congruent.

- ▶ Two triangles are congruent if two sides and the included angle of one triangle are equal to corresponding two sides and the included angle of the second triangle respectively ($SAS \cong SAS$).

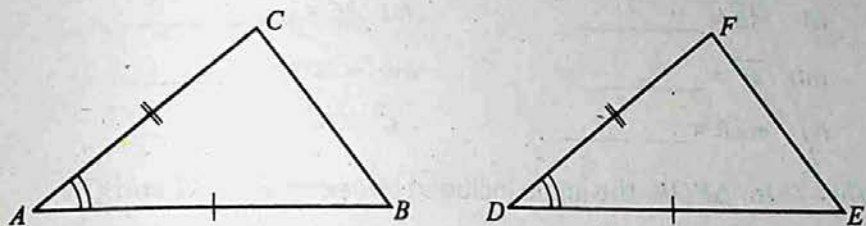

- ▶ Two triangles are congruent if the two angles and included side of one triangle are congruent to corresponding two angles and included side of the other triangle ($ASA \cong ASA$).

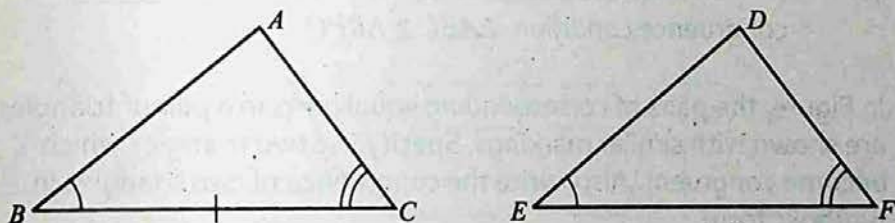

- ▶ The two right angled triangles are congruent if the hypotenuse and a side of one triangle are congruent to the hypotenuse and a corresponding side of the other triangle angle.

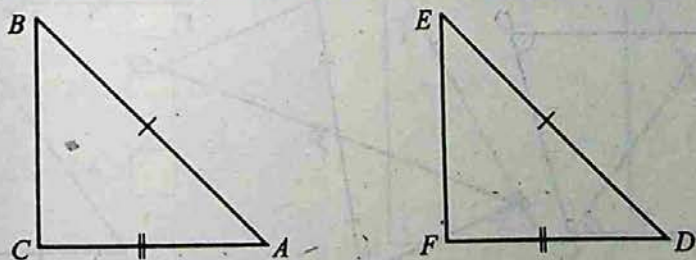

EXERCISE - 7.4

1- Fill in the blanks:

(a) If $\triangle ABC \cong \triangle FDE$, then.

(i) $\overline{AB} =$ _____

(ii) $\overline{BC} =$ _____

(iii) $\overline{AC} =$ _____

(iv) $m\angle A =$ _____

(v) $m\angle B =$ _____

(vi) $m\angle C =$ _____

(b) In $\triangle PQR$, the angle included between side PR and QR is _____

(c) In $\triangle DEF$, the side included between $\angle E$ and $\angle F$ is _____.

(d) If $\overline{AB} = \overline{QP}$, $m\angle B = m\angle P$, $\overline{BC} = \overline{PR}$, then by _____ condition. $\triangle ABC \cong \triangle QPR$.

(e) If $m\angle A = m\angle R$, $m\angle B = m\angle P$, $\overline{AB} = \overline{RP}$ then by _____ congruence condition. $\triangle ABC \cong \triangle RPQ$.

2- In Figure, the pairs of corresponding equal parts in a pair of triangles are shown with similar markings. Specify the two triangles which become congruent. Also, write the congruence of two triangles in symbolic form.

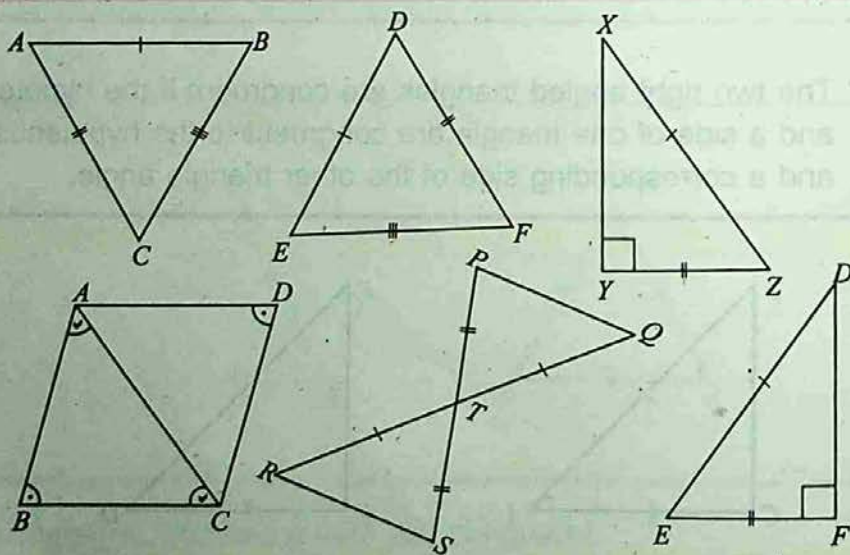

- 3- In Figure, ABC and DBC are two triangles on a common base \overline{BC} such that $\overline{AB} = \overline{DC}$ and $\overline{DB} = \overline{AC}$, where A and D lie on the same side of BC . In $\triangle ADB$ and $\triangle DAC$, state the corresponding parts so that $\triangle ADB = \triangle DAC$.

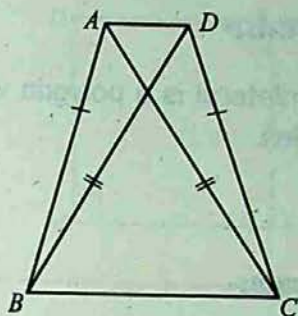

Which condition do you use to establish the congruence?

If $m\angle DCA = 40^\circ$ and $m\angle BAD = 100^\circ$.
Find $\angle ADB$.

- 4- Identify the following figure as congruent, similar or neither.

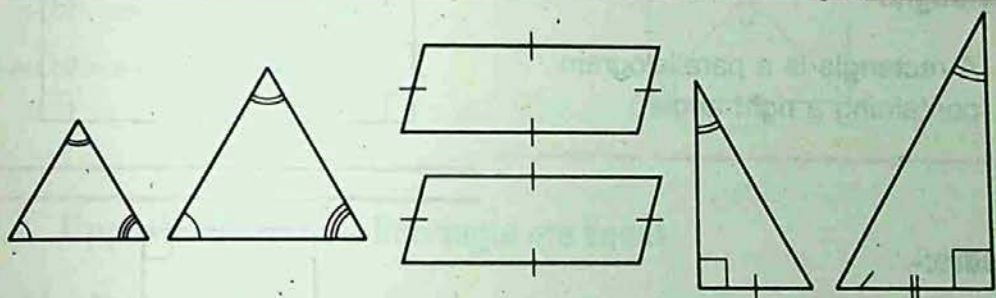

- 5- Identify the corresponding parts in $\triangle MNO$ and $\triangle PQR$.

- (i) $\overline{MN} \leftrightarrow$
 (ii) $\overline{NO} \leftrightarrow$
 (iii) $\overline{PR} \leftrightarrow$
 (iv) $\angle I \leftrightarrow$

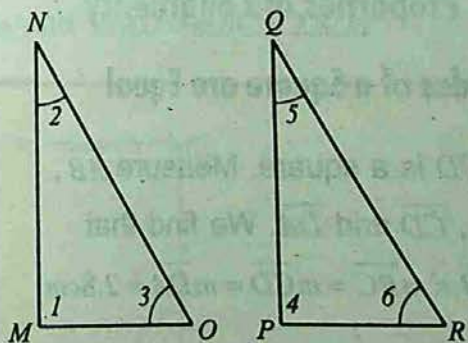

7.5 QUADRILATERALS

Quadrilaterals:-

A quadrilateral is a polygon with four sides.

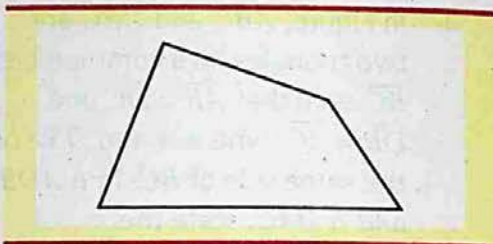

Parallelogram:-

A parallelogram is a quadrilateral with two pairs of parallel sides.

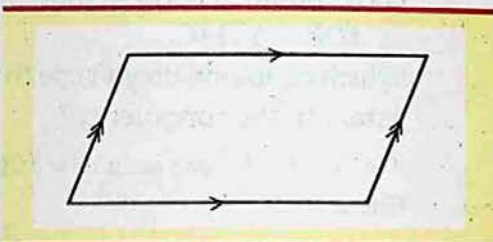

Rectangle:-

A rectangle is a parallelogram containing a right angle.

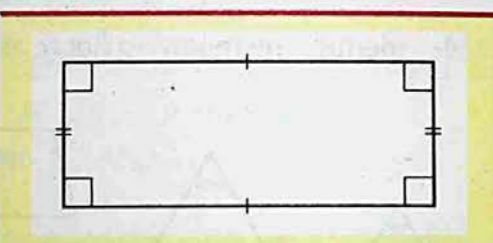

Square:-

A square is an equilateral rectangle.

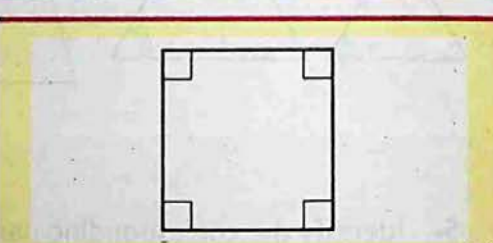

7.5.1 Properties of Congruency

Four Sides of a Square are Equal

$ABCD$ is a square. Measure \overline{AB} , \overline{BC} , \overline{CD} and \overline{DA} . We find that $m\overline{AB} = m\overline{BC} = m\overline{CD} = m\overline{DA} = 2.8\text{cm}$

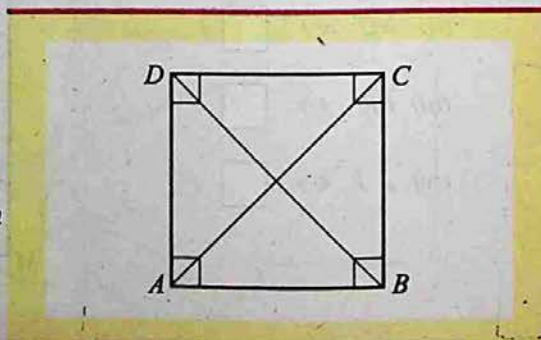

Four Angles of a Square are Right Angles

$ABCD$ is a square.

Measure angle A, B, C, D with protractor. We find that

$$m\angle A = m\angle B = m\angle C = m\angle D = 90^\circ$$

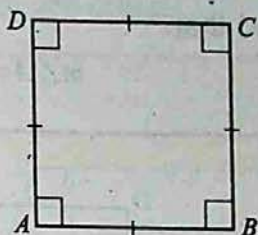

Diagonals of a Square Bisect Each Other

Consider a square $ABCD$, the diagonals \overline{AC} and \overline{BD} intersect at 'O'. We find that

$$m\overline{OA} = m\overline{OC} = 1.9\text{cm} \text{ and}$$

$$m\overline{OB} = m\overline{OD} = 1.9\text{cm}$$

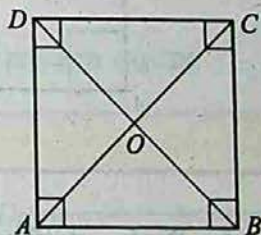

7.5.2 Opposite Sides of a Rectangle are Equal

Consider Rectangle

Let us consider a rectangle $ABCD$.

\overline{AB} , \overline{CD} and \overline{AD} , \overline{BC} are opposite pairs of rectangle $ABCD$.

We find that $m\overline{AB} = m\overline{CD} = 4.5\text{cm}$ and $m\overline{AD} = m\overline{BC} = 2.8\text{cm}$

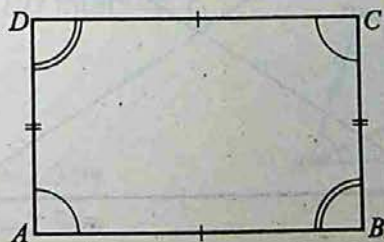

Four Angles of a Rectangle are Right Angles

$ABCD$ is a rectangle. Measure angle A , B , C and D with protractor.
We find that

$$m\angle A = m\angle B = m\angle C = m\angle D = 90^\circ$$

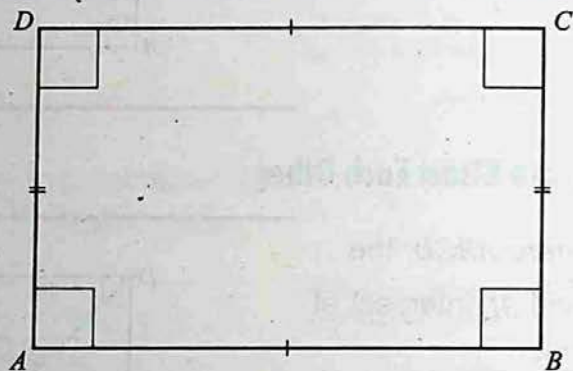

Diagonals of a Rectangle Bisect Each Other

$ABCD$ is a rectangle. Its diagonals \overline{AC} and \overline{BD} intersect at point O .

We find that $m\overline{OA} = m\overline{OC} = 2.5\text{cm}$

and $m\overline{OB} = m\overline{OD} = 2.5\text{cm}$

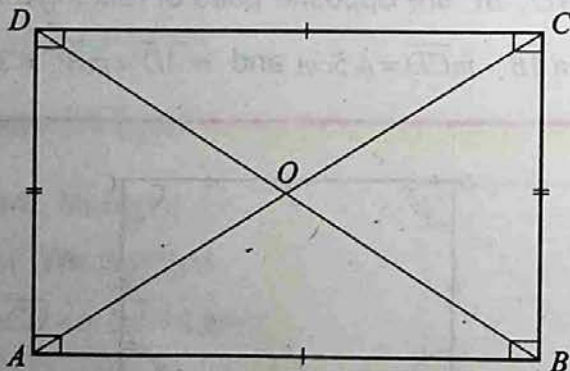

7.5.3 Properties of a Parallelogram

- The opposite sides of a parallelogram are equal.

$ABCD$ is a parallelogram.

\overline{AB} , \overline{CD} and \overline{AD} , \overline{BC} are pairs of opposite sides.

We find that

$$m\overline{AB} = m\overline{CD} = 3.9\text{cm} \text{ and}$$

$$m\overline{AD} = m\overline{BC} = 2.0\text{cm}$$

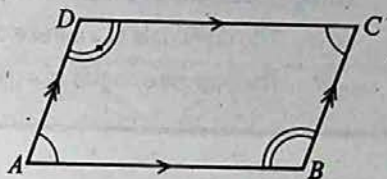

- The opposite angles of a parallelogram are equal.

$ABCD$ is a parallelogram.

$\angle A$, $\angle C$ and $\angle B$, $\angle D$ are pairs of opposite angles.

We find that

$$m\angle A = m\angle C = 70^\circ \text{ and}$$

$$m\angle B = m\angle D = 110^\circ$$

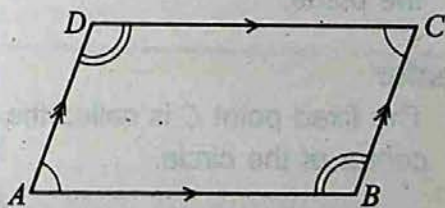

- The diagonals of a parallelogram bisect each other.

A parallelogram $ABCD$, the diagonals \overline{AC} and \overline{BD} intersect at O .

We find that

$$m\overline{OA} = m\overline{OC} = 2.5\text{cm}$$

$$\text{and } m\overline{OD} = m\overline{OB} = 2.5\text{cm}$$

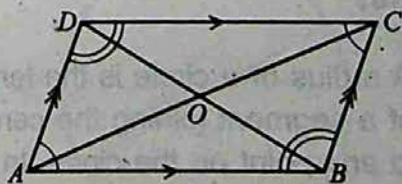

EXERCISE - 7.5

1- Fill in the blanks:

- (i) A parallelogram that contains a right angle is _____.
- (ii) An equilateral rectangle is a _____.
- (iii) A polygon with four sides is a _____.
- (iv) The diagonals of a parallelogram _____ each other.
- (v) The opposite angles of a parallelogram are _____.

7.6 CIRCLE

7.6.1 Circle

A circle is the set of points in a plane which are at a constant distance from a fixed point in the plane.

Center

The fixed point C is called the center of the circle.

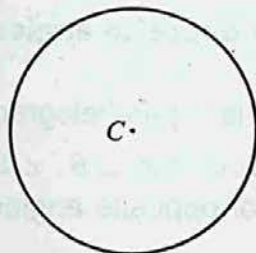

Radial Segment

P is any point on the circumference of the circle with centre O . \overline{OP} is called the radial segment of the circle.

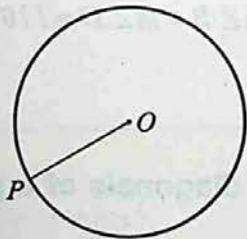

Radius

A radius of a circle is the length of a segment joining the center to any point on the circle. In the given figure $m\overline{CP}$ is the radius. Usually represented by ' r '.

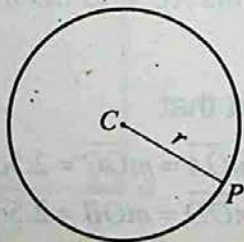

Chord

A chord of a circle is a segment connecting any two points on the circle. In the given figure \overline{AB} is a chord.



Segment of a Circle

A chord \overline{AB} of a circle divides the circle in two parts. These are called segment of the circle.

Minor Segment: The included area between minor arc and the chord is minor segment.

Major Segment: The included area between major arc and chord is called major segment.

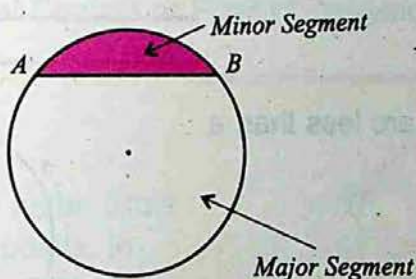

Diameter

A diameter of a circle is a chord that passes through the center. The length of a diameter of a circle is twice the length of the radius of the same circle.

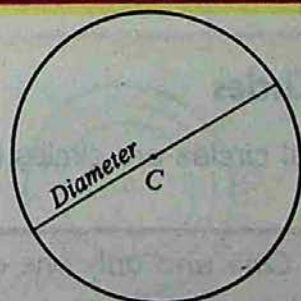

$$\text{Diameter} = 2 \times \text{radius}$$

Arc

An arc is a portion of a circle consisting of two end points and the set of points on the circle between them. An arc is named by its end points. Arc AB (\widehat{AB}) is shown in the figure.

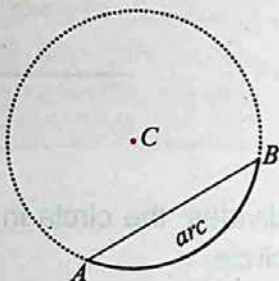
**Semi Circle**

A semi circle is an arc which is half of a circle.

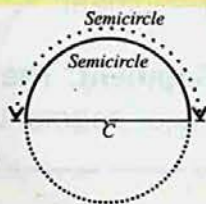
**Minor Arc**

A minor arc is an arc less than a semicircle.

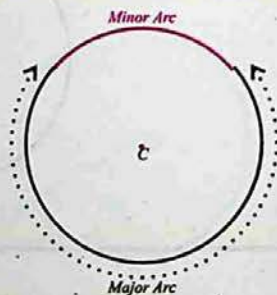
**Major Arc**

A major arc is an arc greater than a semicircle.

Equal Circles

Equal circles are circles having equal radii or equal diameters.

One and only one circle can be constructed with a given center and given radius.

7.6.2 Sector

A circular region bounded by an arc of a circle and its two corresponding radial segments is called a sector of the circle. In the figure, region

AOB is the sector of the circle with center at O .

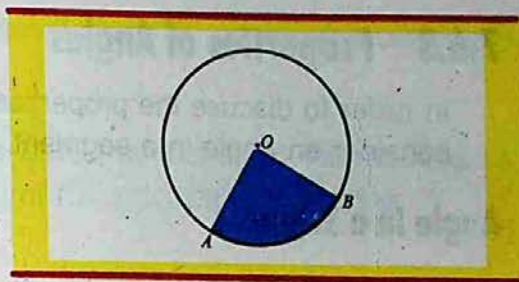

Secant Line

A secant is a line which intersects a circle in two points.

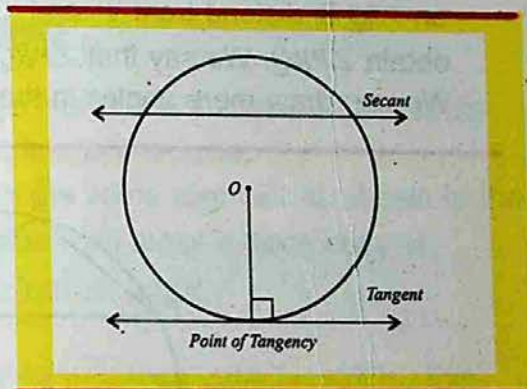

Tangent

A tangent to a circle is the line perpendicular to radius of the circle at its outer extremity.

The point on the circle at which the radius and tangent meet is known as the Point of Contact or Point of Tangency.

Concyclic Points

Points lying on the circumference of the same circle are called concyclic points. In the given figure A, B, C, D, E, F and G are all concyclic points.

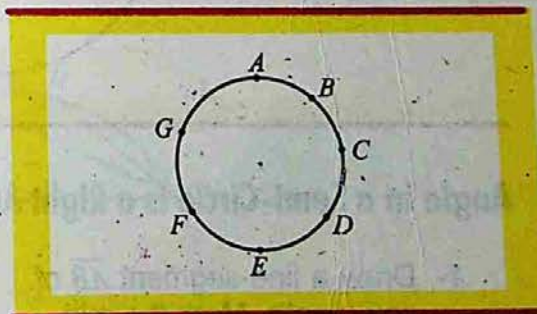

Concentric Circles

Concentric circles are circles in the same plane with the same center and different radii. A set of three concentric circles is shown in the given figure.

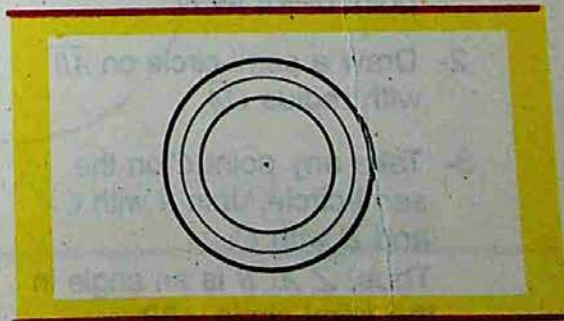

7.6.3 Properties of Angles

In order to discuss the properties of angles relating to circles, first we consider an angle in a segment.

Angle in a Segment

Consider a chord of a circle with center at ' O ' as shown in the figure. We take the segment PSQ of the circle with center at ' O ', the point ' R ' on PSQ is distnd from ' P ' and ' Q '. Join R with P and R with Q to obtain $\angle PRQ$. We say that $\angle PRQ$ is an angle in the segment PSQ . We can draw more angles in the segment to meet by PSQ .

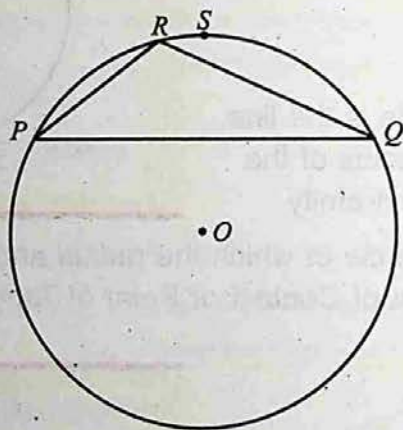

Angle in a Semi-Circle is a Right Angle

- 1- Draw a line-segment \overline{AB} of any length. Mark the mid point of \overline{AB} as O .
- 2- Draw a semi-circle on \overline{AB} with radius \overline{OA} .
- 3- Take any point C on the semi-circle. Join A with C and B with C .

Thus, $\angle ACB$ is an angle in the semi-circle APB .

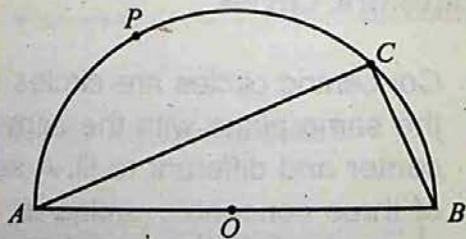

- 4- Now take a protractor and place it along \overline{AC} so that the center of the protractor falls on C .

We note that the measure of the $\angle ACB$ by looking at the marking on the protractor corresponding to arm \overline{CB} of $\angle ACB$ is of 90° , i.e. $m\angle ACB = 90^\circ$ or a right angle.

Thus, angle in a semi-circle is a right angle.

Angles in the Same Segment are Equal

Draw a circle with center ' O '. Take two points B and C on the circle and join them. \overline{BC} divides the circle into two parts.

Draw angles, $\angle BAC$ and $\angle BDC$ in the same segment as shown in the figure. Take a sheet of tracing paper and make a trace copy of $\angle BAC$. Place the trace copy of $\angle BAC$ on $\angle BDC$.

A falls on D and \overline{AB} falls on \overline{DC} .

So that we observe that \overline{BD} falls on \overline{AC} . Thus $\angle BAC = \angle BDC$, this shows that angles in the same segment are equal.

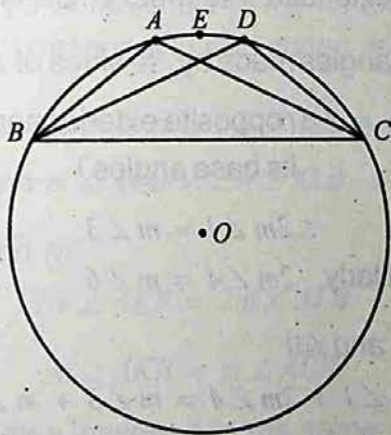

Central Angle

The central angle of a minor arc of a circle is double that the angle subtended by corresponding major arc.

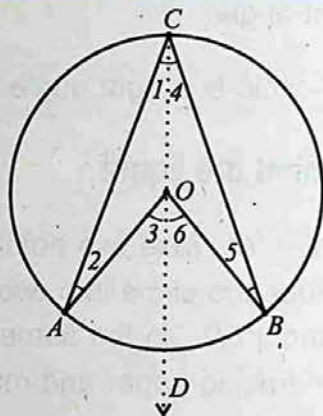

Fig (i)

In Fig (i) $\angle AOB$ is the central angle of minor arc \widehat{AB} while $\angle ACB$ is the major angle subtended by the corresponding major arc \widehat{ACB} of the circle

$$m \angle AOB = m \angle ACB$$

Join C with O and extended it to meet circle in D .

$$m \angle 1 = m \angle 2 \text{ (angles made by } \cong \text{ sides of } \triangle AOC \text{ at base } AC)$$

$$m \angle 1 + m \angle 2 = m \angle 3 \text{ (opposite exterior angle of a } \triangle \text{ is equal to its base angles)}$$

$$\therefore 2m \angle 1 = m \angle 3 \quad \dots\dots\dots(i)$$

$$\text{Similarly } 2m \angle 4 = m \angle 6 \quad \dots\dots\dots(ii)$$

\therefore Adding (i) and (ii)

$$2m \angle 1 + 2m \angle 4 = m \angle 3 + m \angle 6$$

$$2(m \angle 1 + m \angle 4) = m \angle 3 + m \angle 6$$

$$2m \angle ABC = m \angle AOB$$

$$\text{or } m \angle AOB = 2m \angle ACB$$

7.6.4 Applications

All angles inscribed in the same arc are equal in measure.

$$m\angle K = m\angle L = 40^\circ$$

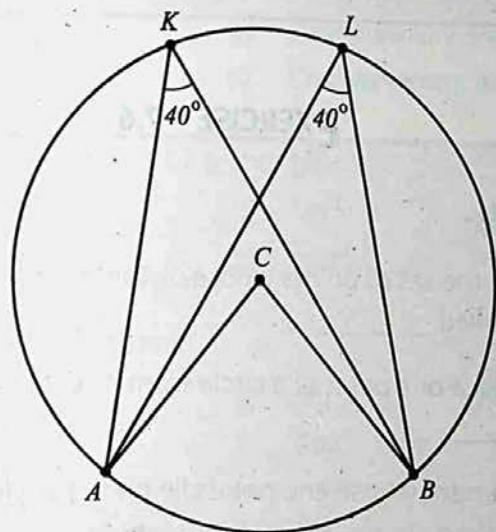

Fig (ii)

$\angle ACB$ is central angle of the circle in Fig (ii) and angle $\angle AKB$ and $\angle ALB$ are the two corresponding subtended angles at the major arc.

$$\therefore m\angle ACB = 2m\angle AKB \dots\dots\dots(i)$$

$$\text{and } m\angle ACB = 2m\angle ALB \dots\dots\dots(ii)$$

\therefore From (i) and (ii)

$$2m\angle AKB = 2m\angle ALB$$

$$m\angle AKB = m\angle ALB$$

Hence all angles inscribed in the same arc are equal.

Remember that:

In congruent circle or in the same circle, if two minor arcs are congruent, then the angles inscribed by their corresponding major arcs are also congruent.

EXERCISE - 7.6**1- Fill in the blanks:**

- (i) In a plane the set of points whose distance from a fixed point is same is called _____.
- (ii) The distance of a point of a circle from its centre is called _____.
- (iii) A line segment whose end points lie on the circle is called _____.
- (iv) A chord that passes through the centre of the circle is called _____.
- (v) Half of a circle is called _____.
- (vi) An arc which is greater than a semicircle is called _____.
- (vii) One and only one circle can be constructed with a given centre and given _____.
- (viii) A region bounded by an arc and two of its radial segments is called _____.
- (ix) A straight line that intersects a circle at two points is called _____.
- (x) Angle in a semi-circle is a _____.

9. An arc greater than a semi-circle is called:

- (a) *Minor arc* (b) *Chord*
(c) *Major arc* (d) *Diameter*

10. Circles with equal radii and equal diameters are called:

- (a) *Concentric circles* (b) *Semi-circles*
(c) *Equal circles* (d) *Concyclic points*

II- Fill in the blanks.

- Two angles with a common vertex and a common side are called _____ angles.
- If sum of the two angles is a straight angle, then the angles are called _____ angles.
- An angle more than 90° and less than 180° is called _____ angle.
- Two non-adjacent angles, each less than a straight angle, formed by two intersecting lines are called _____ angles.
- The sum of the angles of a triangle is _____.
- Two lines parallel to a third line are parallel to _____.
- Two geometrical figures, which have the same size and shape are _____.
- A triangle with no equal sides is called a _____ triangle.
- A chord that passes through the center of a circle is called _____.
- Angle in a semi-circle is a _____ angle.

Vertically Opposite Angles

Given $\angle a = \angle b$ and $\angle c = \angle d$
then \overline{AOB} and \overline{DOC} are straight lines,

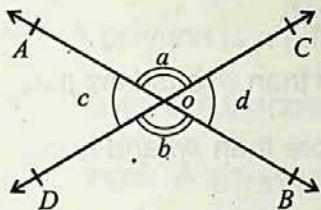

Adjacent Angles on a Straight Line

Given $\angle a + \angle b = 180^\circ$
then \overline{AOB} is a straight line,

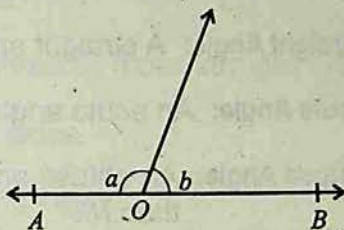

Angles in Relation to Parallel Lines Alternate Angles

Given $\overline{AB} \parallel \overline{CD}$ then $\angle a = \angle b$

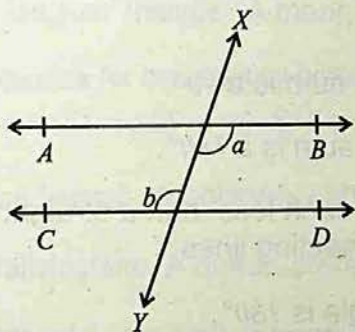

Given $\overline{AB} \parallel \overline{CD}$ then $\angle a = \angle b$

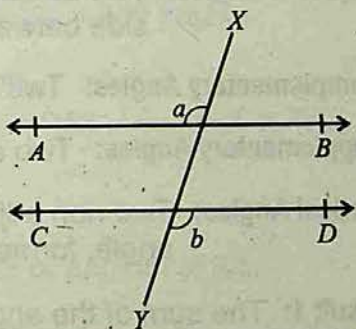

Interior Angles

Given $\angle a + \angle b = 180^\circ$
then $\overline{AB} \parallel \overline{CD}$

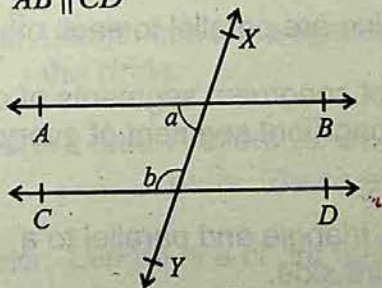

Corresponding Angles

Given $\angle a = \angle b$ then $\overline{AB} \parallel \overline{CD}$

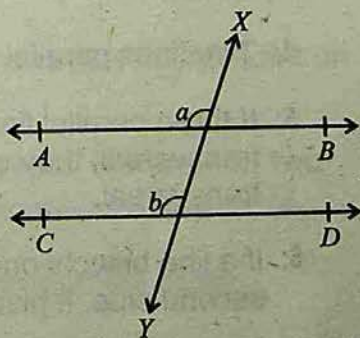

SUMMARY

Angle: An angle is the union of two rays with common end point.

Right Angle: A right angle contains 90° .

Straight Angle: A straight angle contains 180° .

Acute Angle: An acute angle contains more than 0° and less than 90° .

Obtuse Angle: An obtuse angle contains more than 90° and less than 180° .

Reflex Angle: A reflex angle contains more than 180° and less than 360° .

Equal Angles: Equal angles are angles with equal measures.

Adjacent Angles: Two angles with the common vertex and a common side between them.

Complementary Angles: Two angles whose sum is a 90° .

Supplementary Angles: Two angles whose sum is a 180° .

Vertical Angles: Two non adjacent angles, each less than a straight angle, formed by two intersecting lines.

Result 1: The sum of the angles of a triangle is 180° .

2: If two angles are complements of equal angles, they are equal.

3: If two angles are supplements of the same angle, they are equal.

4: Two lines parallel to a third line are parallel to each other.

5: If three parallel lines intercept congruent segments of one transversal, they intercept congruent segment of every transversal.

6: If a line bisects one side of a triangle and parallel to a second side, it bisects the third side.

Transversal: A transversal is a line that intersects two or more lines in different points.

Congruent Figures: Two geometrical figures which have the same size and shape are congruent.

Polygon: A polygon is a plane figure with three or more straight sides.

Isosceles Triangle: A triangle with two equal sides.

Scalene Triangle: A triangle with no equal side.

Right Triangle: A triangle containing one right angle.

Obtuse Triangle: A triangle containing one obtuse angles.

Acute Triangle: A triangle containing three acute angles.

Equiangular Triangle: A triangle containing three equal angles.

Properties for congruency between two Triangles:

(i) $SSS \cong SSS$ (ii) $SAS \cong SAS$ (iii) $ASA \cong ASA$ (iv) $RHS \cong RHS$

Quadrilateral: A polygon with four sides.

Parallelogram: A quadrilateral with two pairs of parallel sides.

Rectangle: A parallelogram containing a right angle.

Square: A equilateral rectangle.

Circle: A set of points in a plane which are at a constant distance from a fixed point.

Radius: Length of a line segment joining the center to any point on the circle.

Segment of a Circle: A chord \overline{AB} of a circle divides the circle in two parts. These are called segment of the circle.

Diameter: Length of a chord that passes through the center.

Arc: A portion of a circle consisting of two end points and the set of points on the circle between them.

Semi Circle: An arc which is half of a circle.

Minor Arc: An arc less than a semi-circle.

Major Arc: An arc greater than a semi-circle.

Equal Circles: Circles having equal radii or equal diameters.

Secant Line: A line which intersects a circle in two points.

Tangent: A line perpendicular to the radius of a circle at its outer extremity.

Sector: A circular region bounded by an arc of a circle and its two corresponding radial segments.

Concyclic Points: Points lying on the circumference of the same circle.

Concentric Circles: Circles in the same plane with same center and different radii.

Central Angle: Angle subtended by an arc at the centre of a circle is called central angle.

- Result:**
- (1) Angle in a semi-circle is a right angle.
 - (2) Angles in the segment of a circle are equal.
 - (3) All angles inscribed in the same arc are equal in measure.

UNIT

8

PRACTICAL GEOMETRY

- ▶ **Construction of a Triangle**
- ▶ **Construction of a Quadrilateral**
- ▶ **Tangent to a Circle**

After completion of this unit, the students will be able to:

- ▶ construct a triangle having:
 - Two sides and the included angle.
 - One side and two of the angles,
 - Two of its sides and the angle opposite to one of them (with all the three possibilities).
- ▶ draw:
 - Angle bisectors.
 - Altitudes.
 - Medians, of a given triangle and verify their concurrency.
- ▶ construct a rectangle when.
 - Two sides are given.
 - Diagonal and one side are given.
- ▶ construct a square when its diagonal is given.
- ▶ construct a parallelogram when two adjacent sides and the angle included between them is given.
- ▶ locate the centre of given circle.
- ▶ draw a circle passing through three given non-collinear points.
- ▶ draw a tangent to a given circle from a point P when P lies.
 - On the circumference,
 - Outside the circle.
- ▶ draw:
 - Direct common tangent or external tangent.
 - Transverse common tangent or internal tangent to two equal circles.
- ▶ draw a tangent to.
 - Two unequal touching circles.
 - Two unequal intersecting circles.

8.1 CONSTRUCTION OF A TRIANGLE

When we are asked to construct a figure, we must use only the tools of geometry, namely, a ruler and a pair of compasses.

8.1.1 Construction

- Construct a triangle, when two sides and the included angle, are given.

Let the given two sides are of measure 7cm and 5cm and the included angle between them is of measure 45° .

Steps of Construction:-

- Draw a line segment $m\overline{BC} = 7\text{cm}$
- At point B , draw $m\angle DBC = 45^\circ$ using compasses.
- With B as centre draw an arc of radius 5cm to cut \overline{BD} at A .
- Join A to C .
- $\triangle ABC$ is the required triangle.

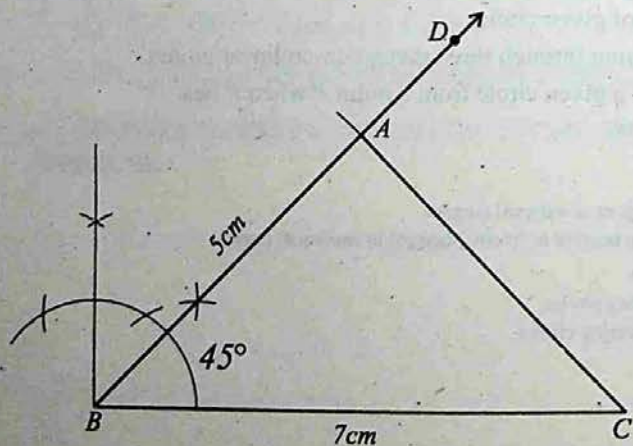

- ▶ **Construct a triangle, when two angles and their included side are given.**

Let the given two angles are $m\angle A = 60^\circ$ and $m\angle B = 30^\circ$ and the included side $m\overline{AB} = 6\text{cm}$

Steps of Construction:-

- Draw a line segment $AB = 6\text{cm}$.
- At point A draw $m\angle BAD = 60^\circ$ with the help of compasses.
- At point B draw $m\angle EBA = 30^\circ$ with the help of compasses.
- \overrightarrow{AD} and \overrightarrow{BE} intersect at C .
- $\triangle ABC$ is the required triangle.

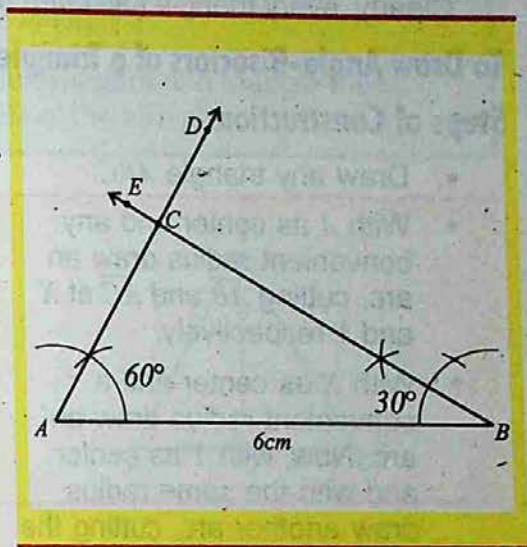

- ▶ **Construct a triangle when two sides and the angle opposite to one of them are given.**

Let $m\angle A = 60^\circ$, $m\overline{AC} = 7\text{cm}$, $m\overline{BC} = 6.5\text{cm}$

Steps of Construction:-

- On any line AG construct $\angle GAF = 60$ with the help of compasses.
- Draw $\overline{AC} = 7\text{cm}$
- With C as center draw an arc of radius 6.5cm cutting line AG in B and B' .
- Draw \overline{CB} and $\overline{CB'}$.

$\triangle CAB$ and $\triangle CAB'$ are the two required triangles.

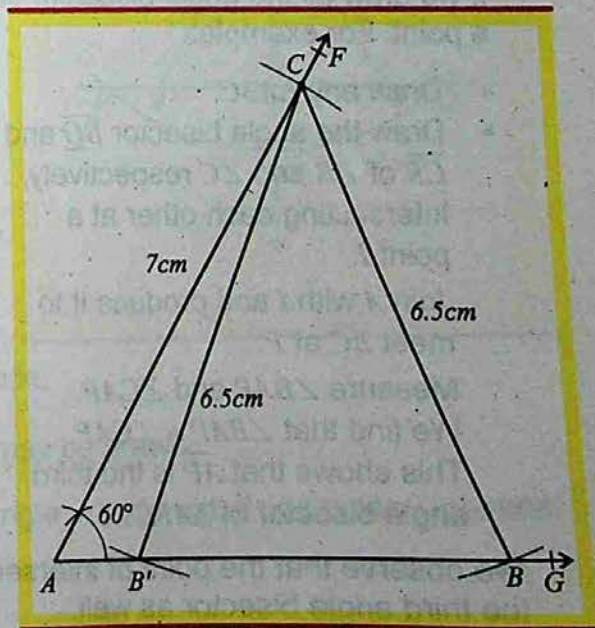

8.1.2 Angle Bisectors of a Triangle

An angle-bisector of a triangle is a line segment that bisects an angle of the triangle and has its other end on the side opposite to that angle. Clearly, every triangle has three angle bisectors, one for each angle.

To Draw Angle-Bisectors of a Triangle

Steps of Construction:-

- Draw any triangle ABC .
- With A as center and any convenient radius draw an arc, cutting \overline{AB} and \overline{AC} at X and Y respectively.
- With X as center and a convenient radius draw an arc. Now, with Y as center and with the same radius draw another arc, cutting the previously drawn arc at Z .
- Join AZ and produce it to meet \overline{BC} at P . Then \overline{AP} is the required angle bisector of $\angle A$.

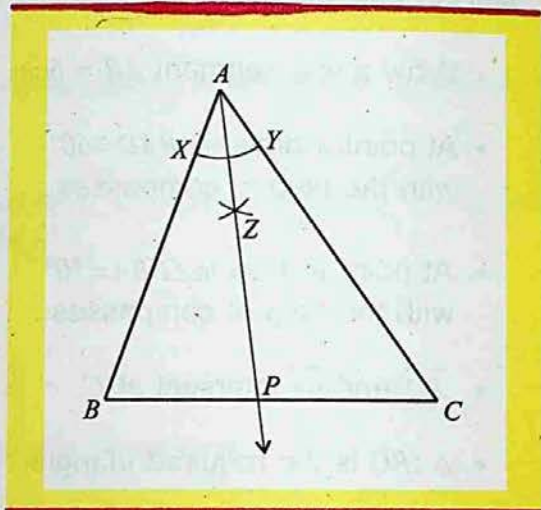

Similarly the other angle bisectors may be drawn.

If we draw all the angle bisectors of a triangle, we find that they meet at a point. For example:

- Draw any $\triangle ABC$.
- Draw the angle bisector \overline{BQ} and \overline{CR} of $\angle B$ and $\angle C$ respectively, intersecting each other at a point I .

Join A with I and produce it to meet \overline{BC} at P .

Measure $\angle BAP$ and $\angle CAP$.

We find that $\angle BAP = \angle CAP$.

This shows that \overline{AP} is the third angle bisector of $\triangle ABC$.

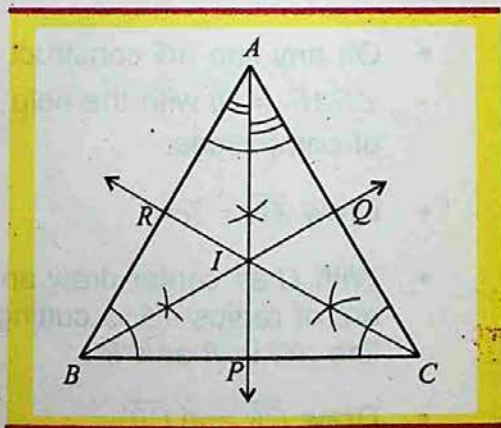

We observe that the point of intersection of two angle bisectors lies on the third angle bisector as well.

The angle bisectors of a triangle are concurrent, that is they meet at a point.

What we need to know ?

The point at which the three angle-bisectors of a triangle meet, is called the **incenter** of the triangle.

Altitudes of a Triangle:-

An altitude of a triangle is the line segment from a vertex of the triangle, perpendicular to the opposite side. Clearly, every triangle has three altitudes, one from each vertex.

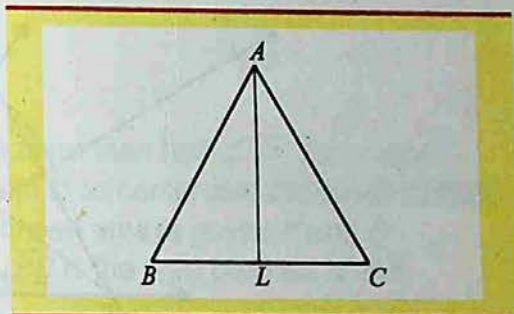

Draw the altitudes of a triangle:-

Steps of Construction:-

- Draw any triangle ABC .
- With A as center and suitable radius, draw an arc cutting \overline{BC} (or BC produced) at two points P and Q .
- With P as center and radius greater than half of \overline{PQ} draw an arc. Now, with Q as center and the same radius, draw another arc, cutting the previously drawn arc at R .
- Join A with R , cutting \overline{BC} at L . Then, \overline{AL} is the required altitude.
- Similarly, the other altitudes may be drawn.

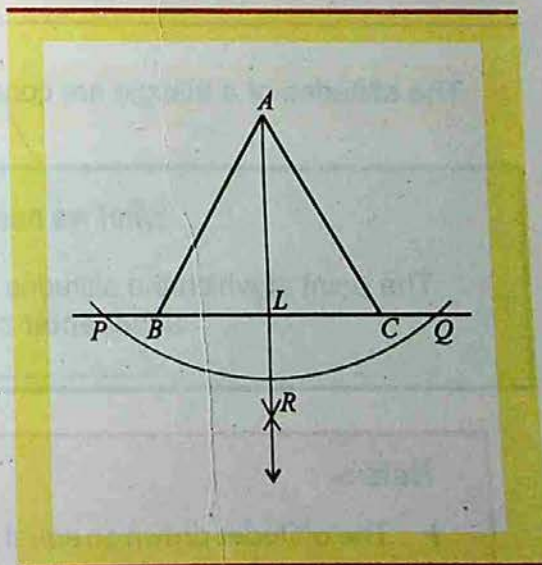

All the three altitudes of a triangle, (produced, if necessary) intersect at a point.

For example:

- Draw any triangle ABC .

From B and C , draw the altitudes \overline{BM} and \overline{CN} respectively.

Let \overline{BM} and \overline{CN} meet in H (produced, if necessary).

Join A with H and produce it, if necessary, to meet \overline{BC} in L .

Measure $\angle ALC$.

We find that $m\angle ALC = 90^\circ$ and, therefore, AL is also an altitude of $\triangle ABC$.

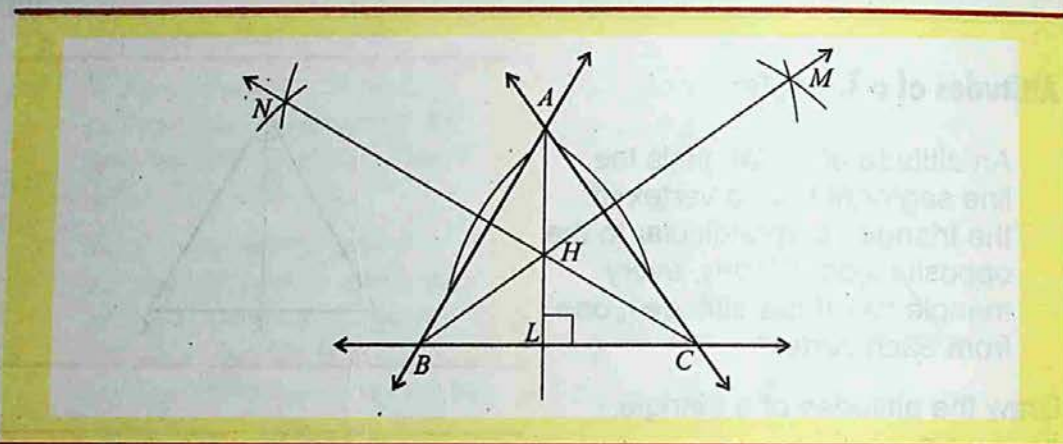

The altitudes of a triangle are concurrent i.e. they meet in one point.

What we need to know ?

The point at which the altitudes of a triangle meet, is called the **orthocenter** of the triangle.

Note :-

- ▶ The altitudes drawn on equal sides of an isosceles triangle are equal.
- ▶ The altitude bisects the base of an isosceles triangle.
- ▶ The altitudes of an equilateral triangle are equal.
- ▶ The altitudes of a triangle are concurrent, that is they meet at a point.

Perpendicular Bisectors of the Sides of a Triangle:-

A line segment which bisects any side of a triangle and makes a right angle with the side at its midpoint is called the perpendicular bisector or the right bisector of the side of the triangle. There are three perpendicular bisectors of a triangle, one of each side.

Construct the perpendicular bisectors of the sides of a triangle

Steps of Construction:-

- Draw any triangle ABC .
- With B as center and any radius more than half of \overline{BC} draw arcs one on each side of \overline{BC} . Now, with C as center and the same radius draw arcs to cut the previously drawn arcs at points P and Q respectively. Join P with Q then, \overline{PQ} is the right bisector of the side \overline{BC} .

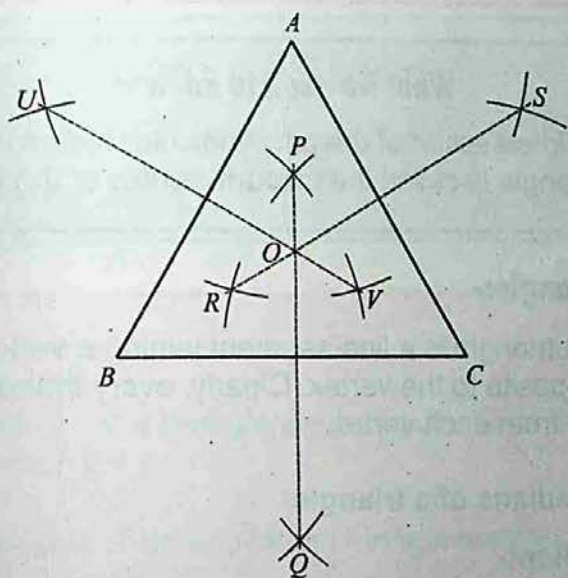

- Also draw the perpendicular bisectors \overline{RS} and \overline{UV} of \overline{AC} and \overline{AB} respectively.
- Produce these right bisectors, if necessary, to meet at a point O .

We find that they meet at a point.
For example:

- Draw any triangle ABC .
- Draw the right bisectors \overline{PL} and \overline{RM} of \overline{BC} and \overline{AC} respectively.

Let \overline{PL} and \overline{RM} intersect at O .

From O , draw $\overline{ON} \perp \overline{AB}$,
meeting \overline{AB} at N .

Measure \overline{AN} and \overline{NB} .

We find that $\overline{AN} = \overline{NB}$.

Thus, \overline{ON} is the perpendicular
bisector of \overline{AB} . Thus, the point O

is common to the three perpendicular bisectors of the sides of $\triangle ABC$.

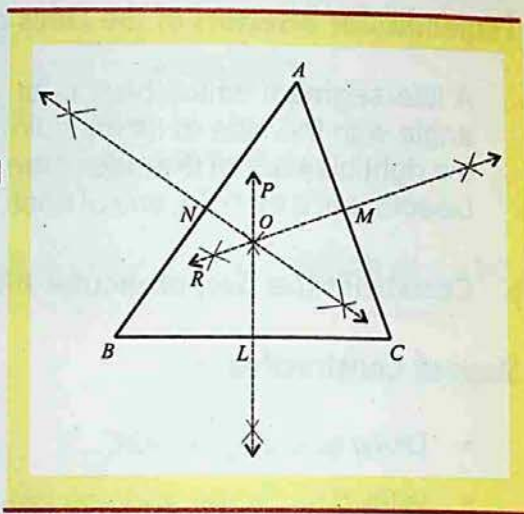

The perpendicular bisectors of the sides of a triangle are concurrent, that is, they meet at a point.

What we need to know ?

The point of intersection of the perpendicular bisectors of the sides of a triangle is called the **circum-center** of the triangle.

Medians Of A Triangle:-

A median of a triangle is a line-segment joining a vertex to the midpoint of the side opposite to the vertex. Clearly, every triangle has three medians, one from each vertex.

► Construct medians of a triangle

Steps of Construction:-

- Draw any triangle ABC .
- With B as center and any radius more than half of \overline{BC} draw arcs one on each side of \overline{BC} . With C as center and the same radius draw two arcs, cutting the previous drawn arcs at points P and Q respectively.

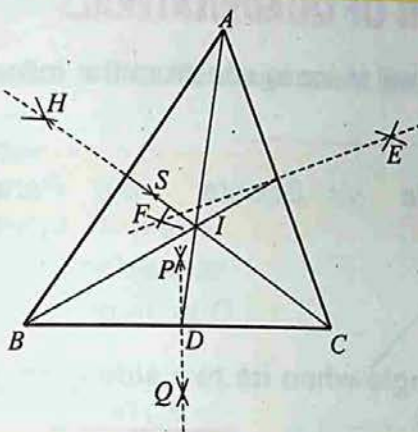

- Join P with Q , meeting \overline{BC} at D . Then, D is the midpoint of \overline{BC} .
- Join A with D , then, \overline{AD} is the required median. Similarly, draw the other medians from B and C . We find that they meet at a point ' I '.

What we need to know ?

The point at which the medians of a triangle meet, is called the **centroid** of the triangle.

Note :-

- ▶ The centroid of a triangle divides each one of the medians in the ratio 2:1
- ▶ The medians of an equilateral triangle are equal.
- ▶ The medians to the equal sides of an isosceles triangle are equal.
- ▶ The medians of a triangle are concurrent.

8.2 CONSTRUCTION OF QUADRILATERALS

In this section, we will learn to construct the following types of quadrilaterals.

(i) Rectangle (ii) Square (iii) Parallelogram

8.2.1 Rectangle

► Construct a rectangle when its two sides are given.

Steps of Construction:-

Draw a line-segment $\overline{AB} = l$.
 Construct $m\angle A = 90^\circ$ and $m\angle B = 90^\circ$. Taking "A" as center cut $\overline{AD} = m$ from \overline{AE} .
 Taking "B" as center cut $\overline{BC} = m$ from \overline{BF} .
 Join C with D.
 Thus ABCD is the required rectangle.

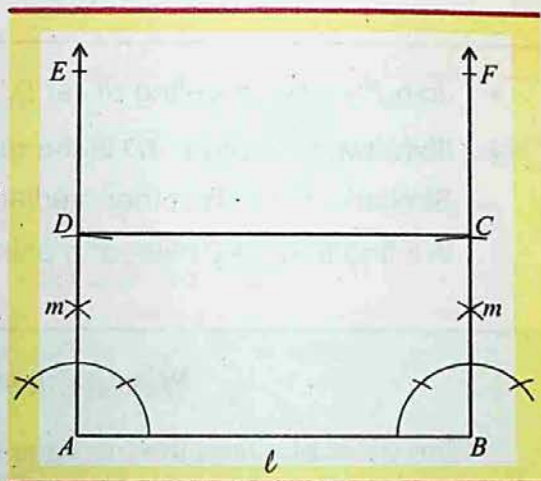

► Construct a rectangle when diagonal and one side are given.

Steps of Construction:-

Draw a line-segment $\overline{AB} = l$.
 Construct $m\angle A = 90^\circ$. Taking "B" as center and radius 'a' draw an arc cutting \overline{AE} at D.
 With B as center and radius \overline{AD} , draw an arc. With D as center and radius $\overline{AB} = l$. Draw another arc \overline{BF} cutting at C. Join C with D.
 ABCD is the required rectangle.

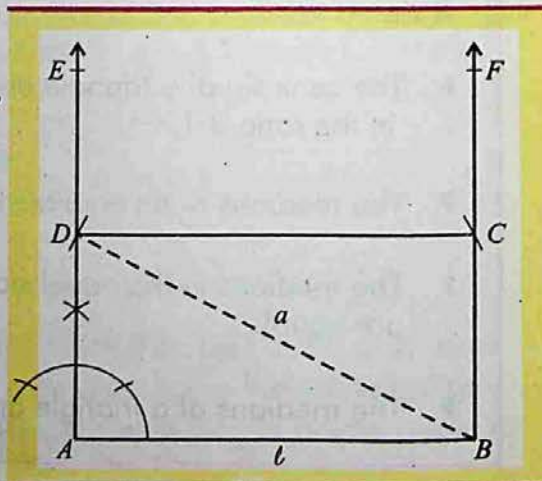

2.2 Square

Construct a square when its diagonal is given.

Steps of Construction:-

Draw a line-segment $\overline{AC} = l$
Draw the perpendicular bisector \overline{PQ} of " \overline{AC} " intersecting \overline{AC} at O .

From " O " cut $\overline{OD} = \frac{l}{2}$ and $\overline{OB} = \frac{l}{2}$
along \overline{OP} and \overline{OQ} respectively.

Join A with B ; B with C ; C with D
and D with A .

$ABCD$ is a square.

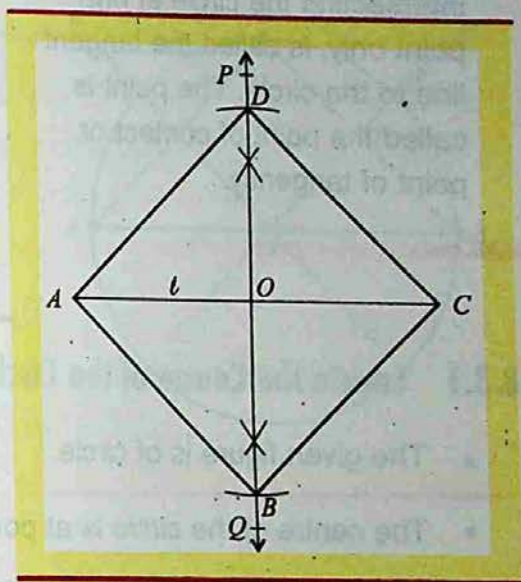

8.2.3 Parallelogram

Construct a parallelogram when two adjacent sides and the angle between them is given.

Draw a line-segment $\overline{AB} = l$.

Construct $\angle BAD = \angle A$.

Cut $\overline{AD} = m$ along AE .

With B as center and radius " m "
draw an arc cutting \overline{BF} at C .

With D as center and radius " l "
draw another arc cutting the
previous arc at " C ". Join C with
 B and C with D . $ABCD$ is the
required parallelogram.

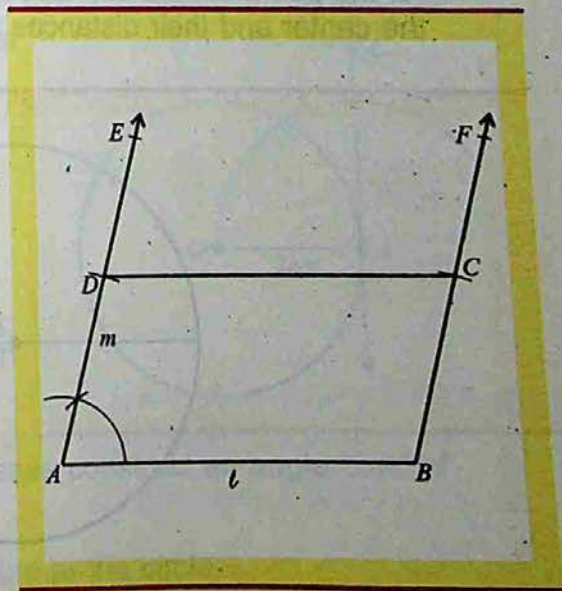

8.3 TANGENT TO THE CIRCLE

A line coplanar with a circle intersecting the circle at one point only, is called the tangent line to the circle. The point is called the point of contact or point of tangency.

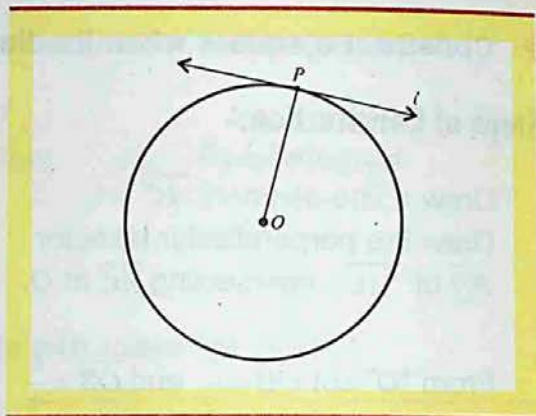

8.3.1 Locate the Centre of the Circle

- The given figure is of circle.
- The centre of the circle is at point " O ".
- There is only one center of the circle.
- Center of the circle is not a point on the curve.
- Center of the circle is the mid point of the diameter.
- All the points on the curved path are at a constant distance from the center and their distances are called radii.

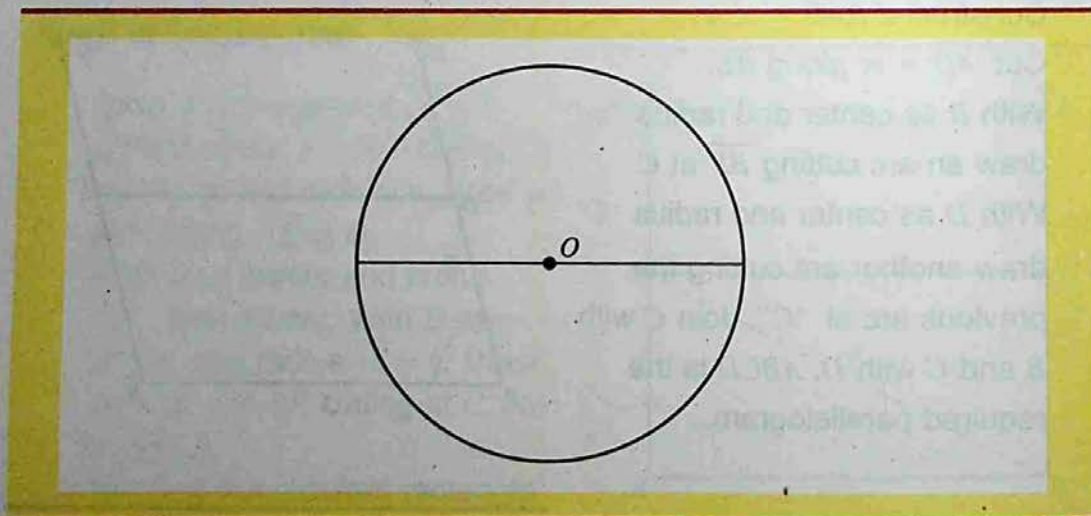

8.3.2 Draw a Circle Passing Through Three Non-Collinear Points

A, B and C are three non-collinear points. We are going to draw a circle through points A, B and C .

Steps of Construction:-

Take any three non-collinear points A, B and C .

- 1- Join A with B ; B with C and C with A , to make a triangle ABC as shown in the figure.
- 2- Draw the right bisectors of the sides AC and BC at points F and E respectively of ΔABC .
- 3- These bisectors meet at point " O ".
- 4- Taking " O " as the center and radius equal to the length $m \overline{OA} = m \overline{OB} = m \overline{OC}$, draw a circle passing through A, B and C .

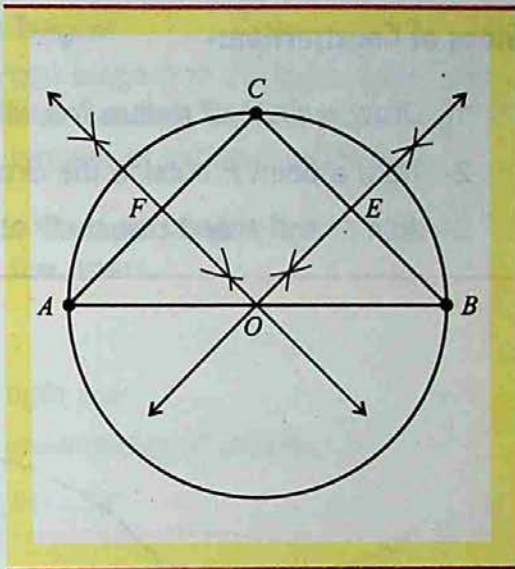

8.3.3 Tangent to a Circle

- Draw a tangent to a circle from a point on the circumference.

Steps of Construction:-

- 1- Draw a circle of radius 2cm with center at " O ".
- 2- Take a point " A " on the circumference of a circle with $m \overline{OA} = 2\text{cm}$.
- 3- With the help of the compasses construct an angle OAC of measure 90° at point A .
- 4- \overrightarrow{AC} is the required tangent line to the circle.

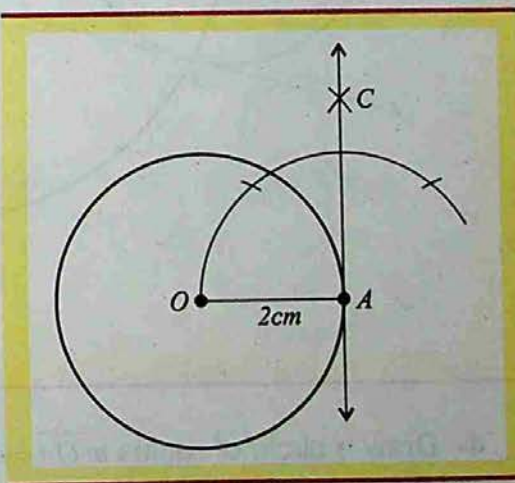

- Draw a tangent to a circle from a point outside the circle.

Steps of Construction:-

- 1- Draw a circle of radius 2cm with center at " O ".
- 2- Take a point P outside the circle.
- 3- Join O and P and bisect OP at A .

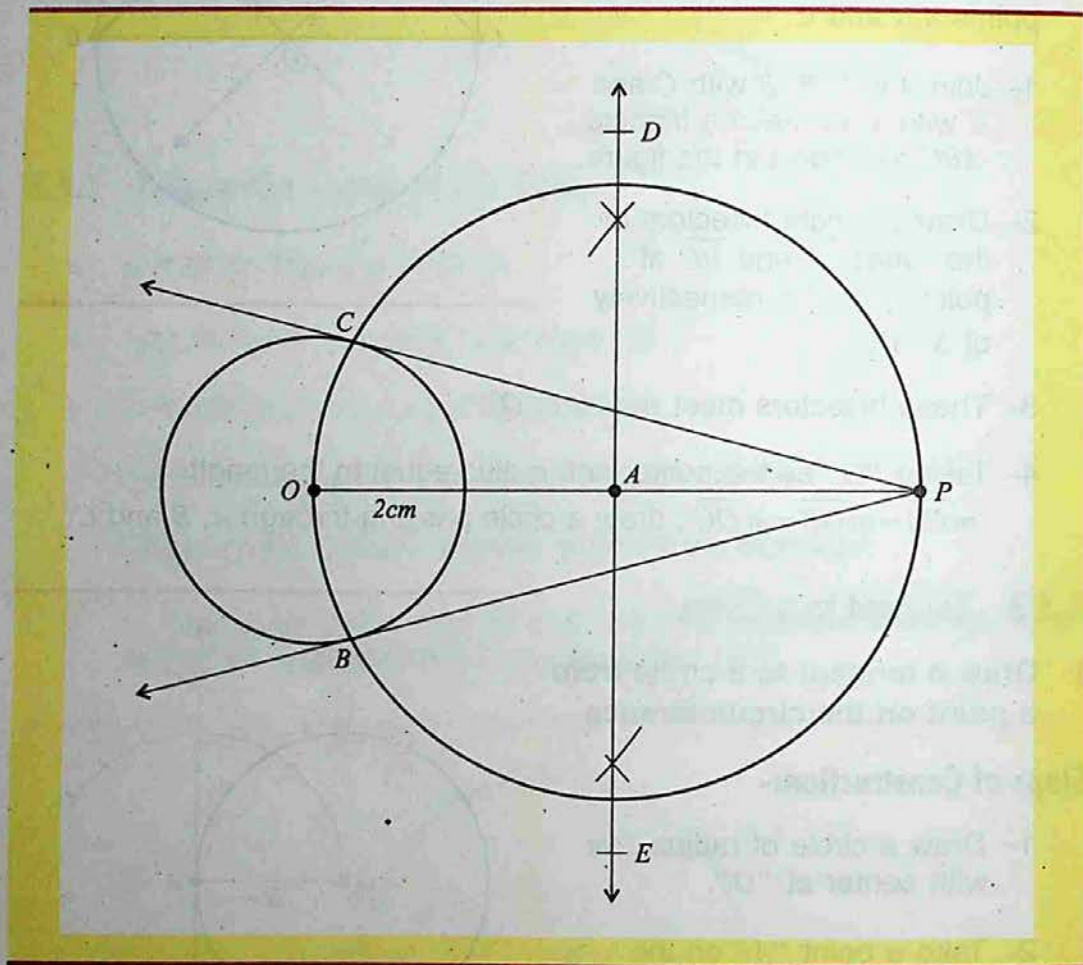

- 4- Draw a circle of radius $m\overline{OA} = m\overline{AP}$ with center at " A ", intersecting the given circle at points B and C .
- 5- Join P with B and produce it.
- 6- \overline{PB} and \overline{PC} are the tangents from point P to the given circle.

8.3.4 Drawing Tangent to Two Equal Circles

Direct Common Tangent or External Tangent

If the points of contact of a common tangent to the two circles are on the same side of the line joining their centers, then this common tangent is called direct common tangent or external tangent.

- Draw direct common tangent to the two circles having same radii 2cm having their centers 5cm apart.

Steps of Construction:-

- 1- Draw a line-segment AB of length 5cm .
- 2- With A and B as two centers draw circles of radius 2cm .
- 3- Draw $m\angle BAE = 90^\circ$ and $m\angle ABD = 90^\circ$.

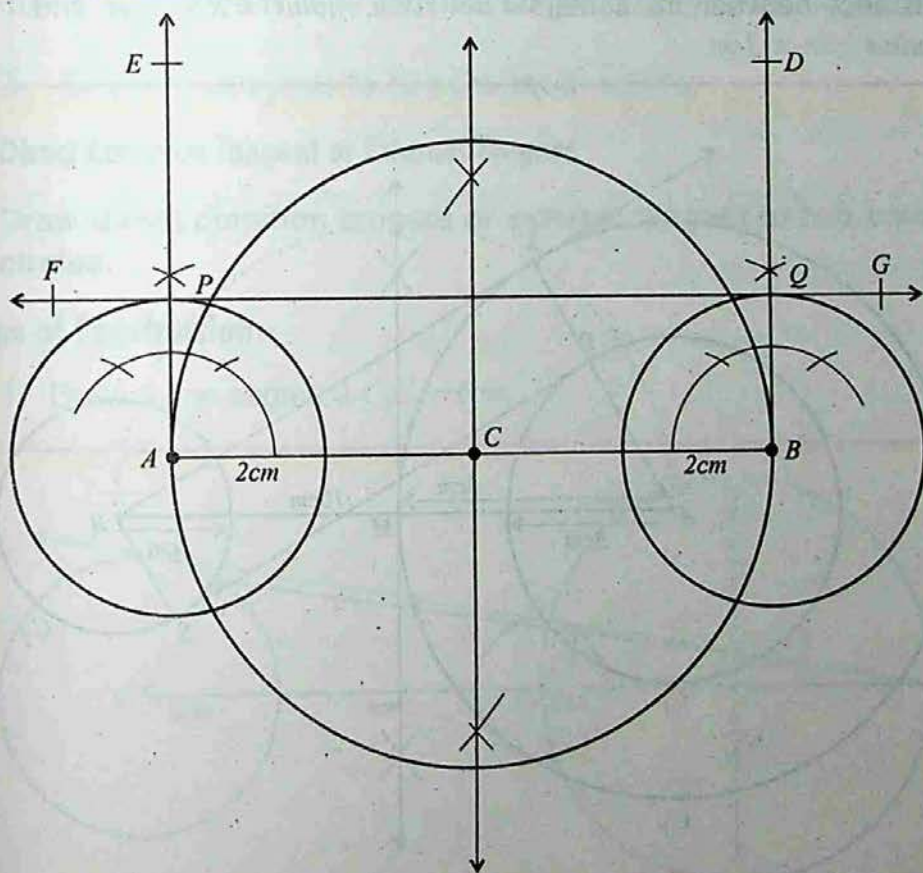

- 4- Draw line segments AE and BD through P and Q respectively.
- 5- Draw a line intersecting the two circles through P and Q respectively.
- 6- \overline{FG} is the required common tangent to the given two equal circles.

Transverse Common Tangent or Internal Tangent

If the centers of the two circles lie on either side of the common tangent then it is called transverse common tangent.

► To construct transverse common tangent to two circles.

Two circles of radii 3cm and 2cm have their centers 10cm apart. Draw transverse common tangents.

Steps of Construction:-

Distance between the centers = $d = 10\text{cm}$, radius = $R = 3\text{cm}$ and radius = $r = 2\text{cm}$.

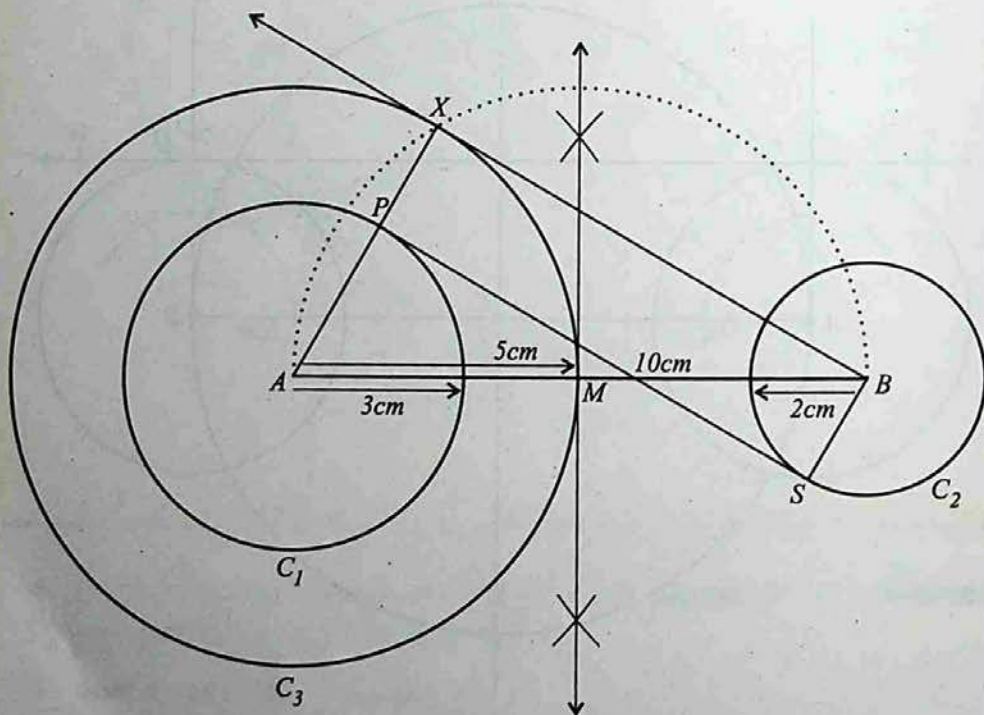

- 1- Draw $\overline{AB} = 10\text{cm}$
- 2- Draw circle C_1 of radius 3cm with "A" as center.
- 3- Draw circle C_2 of radius 2cm with "B" as center.
- 4- Draw circle C_3 of radius 5cm with "A" as center.
- 5- Taking M as a mid point of \overline{AB} draw a semicircle.
- 6- Draw tangent \overline{BX} to the circle C_3 from point B .
- 7- Join A to X (AX intersects circle C_1 at point P).
- 8- From point B , draw $BS \parallel AP$ (by using set square).
- 9- BS intersects circle C_2 at S .
- 10- $\therefore \overline{PS}$ is a transverse common tangent to the circles C_1 and C_2 .

8.3.5 Drawing Tangents to Two Un-Equal Circles

Direct Common Tangent or External Tangent

- Draw direct common tangent or external tangent to two un-equal circles.

Steps of Construction:-

- 1- Draw a line segment $C_1C_2 = 6\text{cm}$.

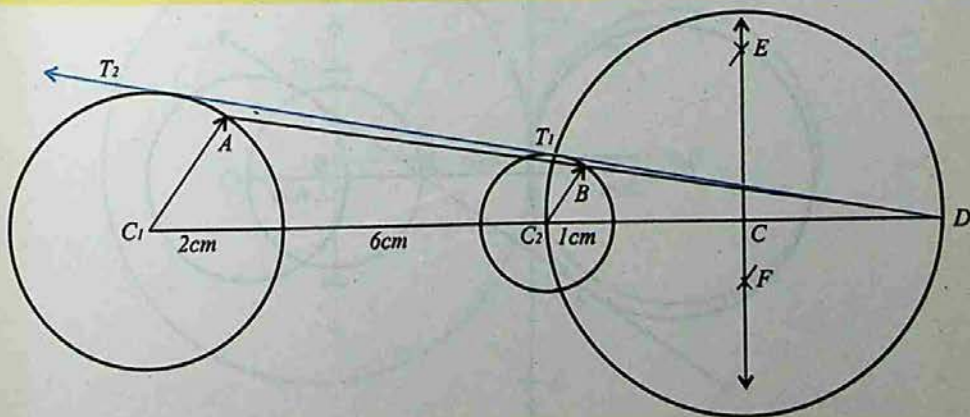

- 2- With centers at C_1 and C_2 draw circle of radius 2cm and 1cm respectively.
- 3- Extend the segment C_1C_2 to the right side.
- 4- From points C_1 and C_2 draw two parallel lines $\overline{C_1A}$ and $\overline{C_2B}$ such that $\angle C_2C_1A$ is an acute angle.
- 5- Join the points A and B extend it to D .
- 6- Draw a bisector of $\overline{C_1D}$ through C_2 .
- 7- Taking C_2 as center and $\overline{CC_2} = \overline{CD}$ radius, draw a circle intersecting the circle with center C_2 at T_1 .
- 8- Draw a line joining the points D and T_1 and touching the circle with center C_1 at T_2 .
- 9- The line $\overline{T_1T_2}$ is the direct common tangent to the given circles.

Transverse Common Tangent or Internal Tangent

- Draw common tangent or internal tangent to two unequal circles.

Steps of Construction:-

- 1- Draw a line-segment 6cm long with C_1 and C_2 as its end points ($m \overline{C_1C_2} = 6\text{cm}$).

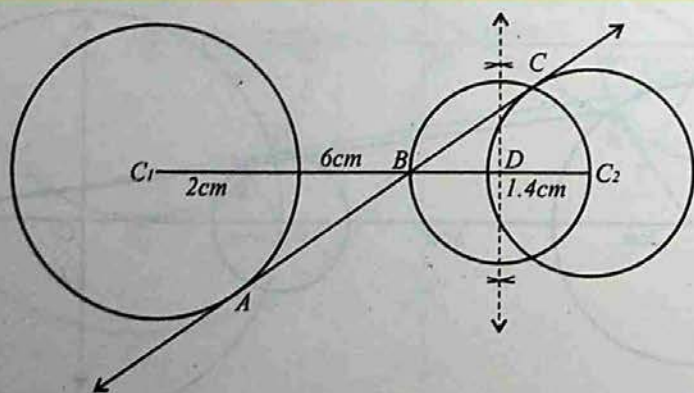

- 2- Taking C_1 as center draw a circle of radius 2cm .
- 3- Taking C_2 as center draw a circle of radius 1.4cm .
- 4- Divide $\overline{C_1C_2}$ in the ratio $1.4:2$ (ratio of radius of the given circles) at point B .
- 5- Bisect the line-segment BC_2 at point D .
- 6- Taking D as center and $m\overline{BD} = m\overline{DC_2} = \text{radius}$, draw a circle intersecting the circle with center at C_2 at point C .
- 7- Draw a line through C and B and touching the second circle at A .
- 8- \overline{AC} is the transverse tangent to the given circles.

8.3.6 Drawing Tangents

Tangent to Two Unequal Touching Circles

- Draw a tangent to two unequal touching circles.

Steps of Construction:-

- 1- Draw two circles of radius 3cm and 2cm touching each other at point C .

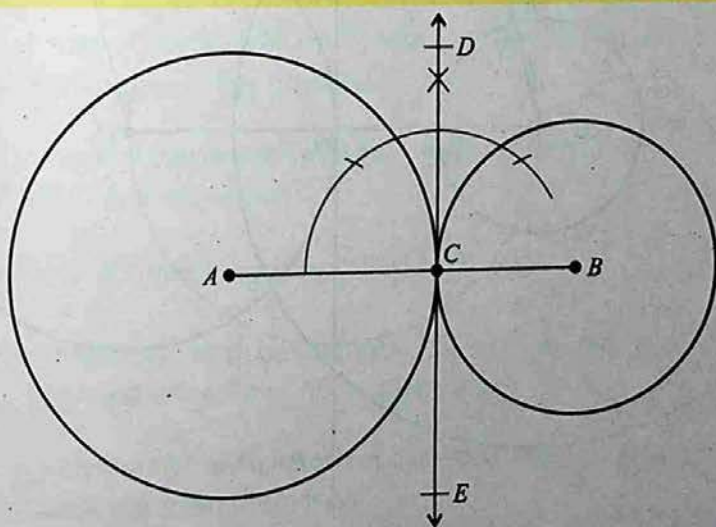

- 2- Draw $m \angle ACD = 90^\circ$ at point C .
- 3- Draw \overline{DE} through C , which is perpendicular to AB .
- 4- \overline{DE} is the required common tangent to the given two unequal touching circles.

Tangent to Two Unequal Intersecting Circles

- Draw a tangent to two unequal intersecting circles.

Construction:-

- 1- Draw a line-segment C_1C_2 of length 4cm .
- 2- Taking C_1 and C_2 as centers, draw two circles of radius 3cm and 2cm intersecting at points A and B respectively.
- 3- Taking C_1 as center draw a circle of radius $3\text{cm} - 2\text{cm} = 1\text{cm}$.

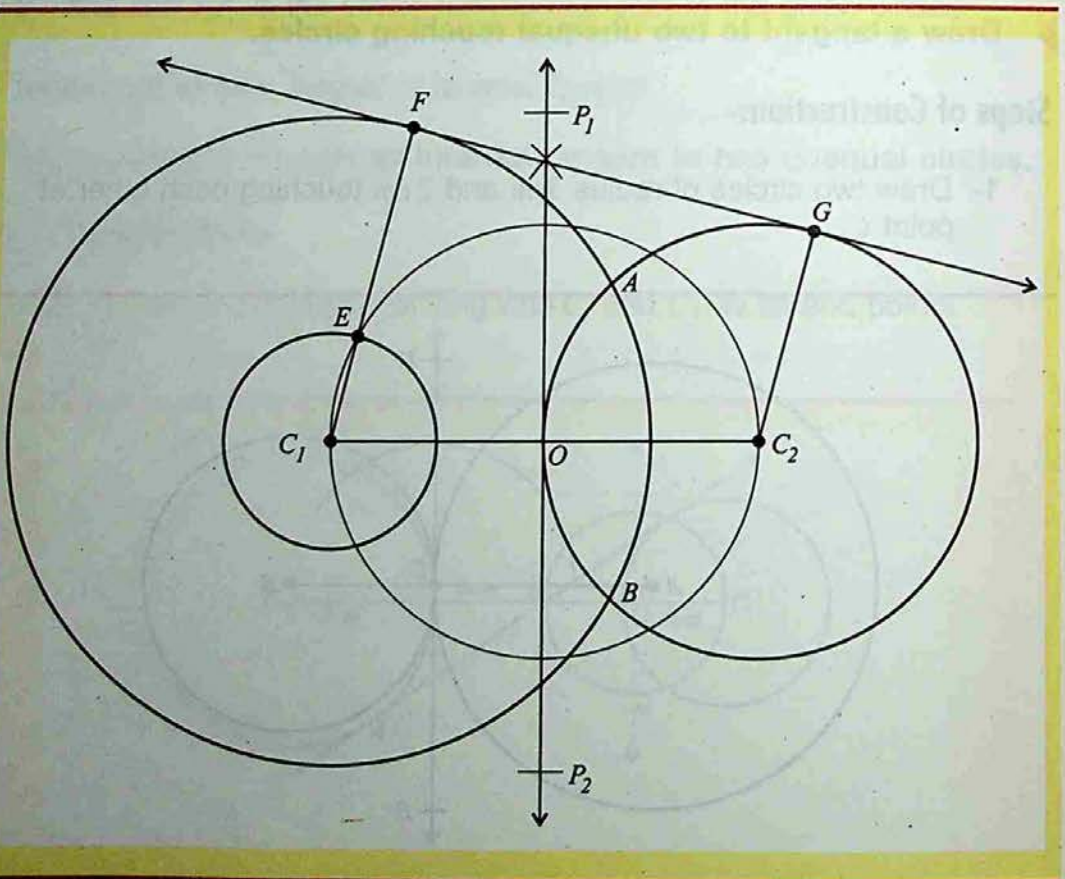

Bisect the line-segment C_1C_2 at O .

Taking O as center and $m\overline{C_1O} = m\overline{C_2O} = \text{radius}$, draw a circle intersecting the inner circle at point E .

Join the point C_1 to E and extend it to intersect the concentric circle at F .

Draw a line from C_2 , parallel to $\overline{C_1F}$ intersecting the circle with center C_2 at point G .

Draw a line joining the points F and G .

The line \overline{FG} is the direct common tangent to two unequal intersecting circles.

EXERCISE - 8.1

Draw a triangle ABC in which $m\overline{BC} = 5.4\text{cm}$, $m\overline{AB} = 4.3\text{cm}$ and $m\overline{AC} = 3.9\text{cm}$. Find the in center.

Construct a ABC in which $m\overline{BC} = 4.6\text{cm}$, $\angle B = 110^\circ$ and $m\overline{AB} = 5\text{cm}$. Draw the perpendicular bisectors of its sides.

Draw an equilateral ΔABC in which $m\overline{AB} = m\overline{BC} = m\overline{AC} = 5\text{cm}$. Draw its altitudes and measure their lengths are they equal?

Construct a ΔABC in which $m\overline{BC} = 5.4\text{cm}$, $m\angle B = 65^\circ$ and $m\angle C = 55^\circ$. Find the centroid of the triangle.

Draw an equilateral triangle each of whose sides is 5.3 cm . Draw its medians. Are they equal?

Draw an equilateral triangle with length of each side 6 cm .

Construct a triangle ABC with base length 5cm and the angles at both ends of the base are 45° and 60° respectively.

Draw an isosceles triangle with length of the equal sides 5cm and the angle included between them is 60° .

- 9- Construct a rectangle whose adjacent sides are 4cm and 3cm .
- 10- Construct a rectangle whose one side is 6cm and an adjacent diagonal of 9cm .
- 11- Construct a square whose one side is 5cm .
- 12- Construct a square whose one side is 3.5cm .
- 13- Construct a rectangle whose two adjacent sides measure 5cm and 4cm and their included angle is 90° .
- 14- Draw a rectangle whose one side is 8cm and the length of each diagonal is 10cm .
- 15- Draw a rectangle $ABCD$ in which $m \overline{AB} = 6.5\text{cm}$ and $m \overline{AD} = 4.8\text{cm}$ and $m \angle BAD = 90^\circ$. Measure its diagonals.
- 16- Name the following quadrilaterals when:
 - (i) The diagonals are equal and the adjacent sides are unequal.
 - (ii) The diagonals are equal and the adjacent sides are equal.
 - (iii) All the sides are equal and one angle is 90° .
 - (iv) All the angles are equal and the adjacent sides are unequal.
- 17- Construct a rectangle with sides 10cm and 6cm .
- 18- Construct a square with side of length 6cm .
- 19- Name the following triangles.
 - (i) With all the three sides equal in length.
 - (ii) With two sides equal in length.
 - (iii) None of the sides is equal to the other.

- 20- Draw a circle with center O and radius 5cm . Explain the steps necessary to draw a segment of the circle.
- 21- Draw a circle with center O and any radius. Draw the diameter AB and shade one semicircular region.
- 22- Show four angles in a semi-circular region of question 21.
- 23- Draw a circle of radius 2cm with center O . Draw a chord and shade the portion showing major arc.
- 24- Draw a circle of radius 2.5cm with center at O . Draw a chord and shade the portion showing the minor arc of the circle.
- 25- Draw a semi-circle with diameter 4cm and center at O .
- 26- Draw a circle passing through the vertices of a square of side 3cm .
- 27- In a right triangle ABC , $m\overline{AB} = 3\text{cm}$ and $m\overline{BC} = 4\text{cm}$ with right angle at B . Draw a circle through A, B and C .
- 28- Draw a circle passing through the three vertices of an equilateral triangle with length of each side 4cm .

Review Exercise-8

I- Encircle the Correct Answer.

1. The number of medians in a triangle is:

- (a) 1 (b) 2
(c) 3 (d) 4

2. The number of altitudes in a triangle is:

- (a) 1 (b) 2
(c) 3 (d) 4

3. The number of angle bisectors in a triangle is:

- (a) 1 (b) 2
(c) 3 (d) 4

4. The number of perpendicular bisectors of the side of a triangle is:

- (a) 1 (b) 2
(c) 3 (d) 4

5. The angle bisectors of a triangle are:

- (a) concurrent (b) collinear
(c) perpendicular (d) non-concurrent

6. The medians of a triangle are:

- (a) concurrent (b) collinear
(c) non-concurrent (d) 4

7. The altitudes of a triangle are:

- (a) concurrent (b) collinear
(c) non-collinear (d) 5

8. A line joining one vertex of a triangle to the mid point of its opposite sides is called:

- (a) angle bisector (b) altitude
(c) median (d) side bisector

9. A line joining one vertex of a triangle and perpendicular to its opposite side is called:

- (a) *angle bisector* (b) *median*
(c) *altitude* (d) *side bisector*

10. A line coplanar with a circle and intersecting the circle at one point only is called:

- (a) *tangent line* (b) *median*
(c) *altitude* (d) *normal line*

II- Fill in the blanks.

1. The altitudes of a triangle are _____
2. The medians of a triangle are _____
3. The angle bisector of a triangle are _____
4. The perpendicular bisector of the three sides of a triangle are _____
5. The line joining one vertex of a triangle and perpendicular to its opposite side is called _____ of a triangle.
6. A line joining one vertex of a triangle to the midpoint of its opposite side is called _____ of a triangle.
7. A line bisecting the angle of a triangle is called the _____.
8. Every triangle has _____ altitudes.
9. Every triangle has _____ median.
10. Every triangle has _____ right bisectors.

SUMMARY

- 1- An angle bisector of a triangle is a line segment that bisects an angle of the triangle and has its other end on the side opposite to that angle.
- 2- Every triangle has three angle bisectors, one for each angle.
- 3- An altitude of a triangle is the line segment from one vertex, perpendicular to the opposite side.
- 4- Every triangle has three altitudes, one from each vertex.
- 5- A line-segment which bisects any side of a triangle and makes a right angle with the sides at its mid point is called the perpendicular bisector of the side of a triangle.
- 6- Every triangle has three perpendicular sides bisectors, one for each side.
- 7- The point at which the three angle bisectors of a triangle meet is called the incenter of the triangle.
- 8- The point at which the three altitudes of a triangle meet is called the orthocenter of the triangle.
- 9- The point of intersection of the three perpendicular bisectors of the sides of a triangle is called the circum-center of the triangle.
- 10- The point at which the three medians of a triangle meet is called the centroid of the triangle.
- 11- A line coplanar with a circle intersecting the circle at one point only is called the tangent line to the circle.

UNIT

9

Areas and Volumes

- ▶ **Pythagoras Theorem**
- ▶ **Area**
- ▶ **Volume**

After completion of this unit, the students will be able to:

- ▶ state Pythagoras theorem.
- ▶ solve right angled triangle using Pythagoras theorem.
- ▶ find the area of
 - A triangle when three sides are given (apply Hero's formula),
 - A triangle whose base and altitude are given.
 - An equilateral triangle when its side is given.
 - A rectangle when its two sides are given.
 - A parallelogram when base and altitude are given.
 - A square when its side is given.
 - Four walls of a room when its length, width and height are given.
- ▶ find the cost of turfing a square/rectangular field.
- ▶ find the number of tiles, of given dimensions, required to pave the footpath of given width carried around the outside of a rectangular plot.
- ▶ find the area of circle and a semi circle when radius is given.
- ▶ find the area enclosed by two concentric circles whose radii are given.
- ▶ solve real life problems related with areas of triangle, rectangle, square, parallelogram and circle.
- ▶ find the volume of:
 - A cube when its edge is given.
 - A cuboid when its breadth and height are given.
 - A right circular cylinder whose base radius and height are given.
 - A right circular cone whose radius and height are known.
 - A sphere and a hemisphere when radius is given.
- ▶ solve real life problems related to volume of cube, cuboid, cylinder, cone and sphere.

SUMMARY

- 1- An angle bisector of a triangle is a line segment that bisects an angle of the triangle and has its other end on the side opposite to that angle.
- 2- Every triangle has three angle bisectors, one for each angle.
- 3- An altitude of a triangle is the line segment from one vertex, perpendicular to the opposite side.
- 4- Every triangle has three altitudes, one from each vertex.
- 5- A line-segment which bisects any side of a triangle and makes a right angle with the sides at its mid point is called the perpendicular bisector of the side of a triangle.
- 6- Every triangle has three perpendicular sides bisectors, one for each side.
- 7- The point at which the three angle bisectors of a triangle meet is called the incenter of the triangle.
- 8- The point at which the three altitudes of a triangle meet is called the orthocenter of the triangle.
- 9- The point of intersection of the three perpendicular bisectors of the sides of a triangle is called the circum-center of the triangle.
- 10- The point at which the three medians of a triangle meet is called the centroid of the triangle.
- 11- A line coplanar with a circle intersecting the circle at one point only is called the tangent line to the circle.

UNIT

9

Areas and Volumes

- ▶ **Pythagoras Theorem**
- ▶ **Area**
- ▶ **Volume**

After completion of this unit, the students will be able to:

- ▶ state Pythagoras theorem.
- ▶ solve right angled triangle using Pythagoras theorem.
- ▶ find the area of
 - A triangle when three sides are given (apply Hero's formula),
 - A triangle whose base and altitude are given.
 - An equilateral triangle when its side is given.
 - A rectangle when its two sides are given.
 - A parallelogram when base and altitude are given.
 - A square when its side is given.
 - Four walls of a room when its length, width and height are given.
- ▶ find the cost of turfing a square/rectangular field.
- ▶ find the number of tiles, of given dimensions, required to pave the footpath of given width carried around the outside of a rectangular plot.
- ▶ find the area of circle and a semi circle when radius is given.
- ▶ find the area enclosed by two concentric circles whose radii are given.
- ▶ solve real life problems related with areas of triangle, rectangle, square, parallelogram and circle.
- ▶ find the volume of:
 - A cube when its edge is given.
 - A cuboid when its breadth and height are given.
 - A right circular cylinder whose base radius and height are given.
 - A right circular cone whose radius and height are known.
 - A sphere and a hemisphere when radius is given.
- ▶ solve real life problems related to volume of cube, cuboid, cylinder, cone and sphere.

9.1 PYTHAGORAS THEOREM

Pythagoras Theorem :-

The square of the hypotenuse of a right triangle is equal to the sum of the squares of the two sides.

$$c^2 = a^2 + b^2$$

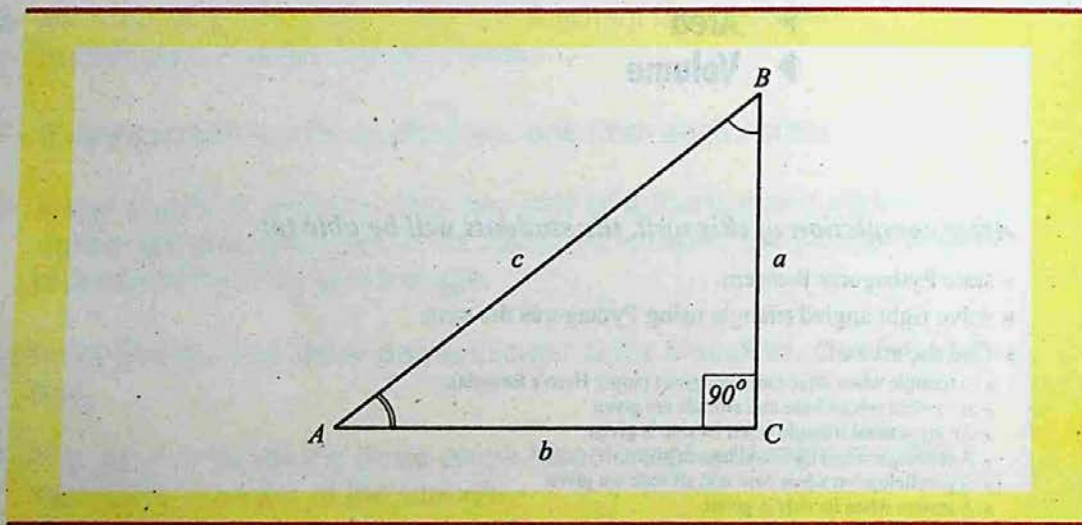

EXAMPLE-1

The sides of a right triangle are 5cm and 12cm.
Find the hypotenuse.

SOLUTION: Given: $a = 5\text{cm}$, $b = 12\text{cm}$,

Let the length of hypotenuse be c .

Then by pythagoras theorem.

$$\begin{aligned} c^2 &= a^2 + b^2 \\ &= (5)^2 + (12)^2 \\ &= 25 + 144 = 169 \\ c &= 13\text{cm} \end{aligned}$$

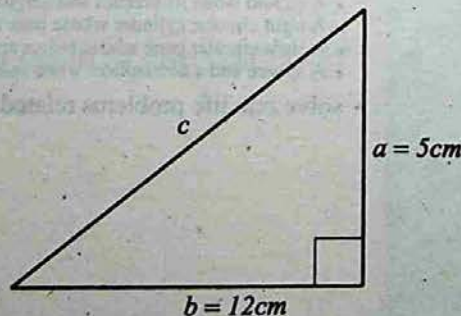

EXAMPLE-2

A 25m ladder leans against a house with its foot 15m from the house. How far is the top of the ladder from the ground?

SOLUTION: Given: $a = 15m$, $c = 25m$

Let b represents the desired distance.

$$\text{Then } a^2 + b^2 = c^2$$

$$b^2 = c^2 - a^2$$

$$= (25)^2 - (15)^2$$

$$= 625 - 225$$

$$= 400$$

$$b = 20m$$

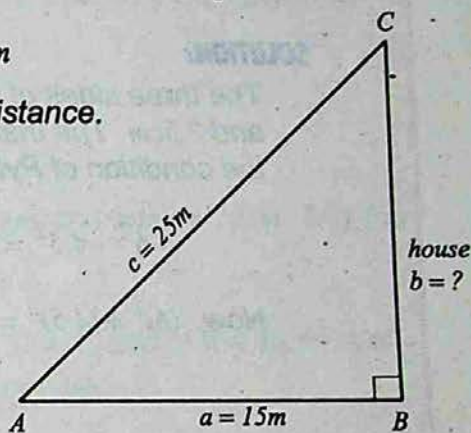
**EXAMPLE-3**

If 30, 72, 78 represent the lengths of the sides of a triangle. Is triangle a right triangle?

SOLUTION: Given: $a = 30$, $b = 72$, $c = 78$

We have pythagoras theorem, it states: $c^2 = a^2 + b^2$

$$R.H.S = a^2 + b^2 = (30)^2 + (72)^2$$

$$= 900 + 5184$$

$$= 6084$$

$$L.H.S = c^2 = (78)^2$$

$$= 6084$$

$$R.H.S = L.H.S$$

Thus triangle is a right triangle.

EXAMPLE-4

The sides of a triangle are of lengths 6cm, 4.5cm and 7.5cm.
Is this triangle a right triangle? If so, which side is the hypotenuse?

SOLUTION:

The three sides of the triangle are given to be 6cm, 4.5cm and 7.5cm. The triangle will be a right triangle if it satisfies the condition of Pythagoras theorem

$$6^2 + 4.5^2 = 7.5^2$$

$$\begin{aligned} \text{Now } (6)^2 + (4.5)^2 &= 36 + 20.25 \\ &= 56.25 = (7.5)^2 \end{aligned}$$

Since the relation $6^2 + 4.5^2 = 7.5^2$ is satisfied, therefore, the triangle whose sides are 6cm, 4.5cm, 7.5cm is a right triangle.

$$\text{Also } 7.5^2 = 6^2 + 4.5^2$$

\therefore The side of length 7.5cm is the hypotenuse of the triangle.

EXERCISE - 9.1

- Find the third side of each right triangle with legs a and b and hypotenuse c .
 - $a = 3$, $b = 4$, $c = ?$
 - $a = 5$, $c = 13$, $b = ?$
 - $b = 5$, $c = 61$, $a = ?$
- If the legs of a right triangle are $2ab$ and $a^2 - b^2$, prove that the hypotenuse is $a^2 + b^2$.
- Find the hypotenuse of the right isosceles triangle each of whose legs is l .

- 4- Find the hypotenuse of a right isosceles triangle whose legs are 8cm .
- 5- If the numbers represent the lengths of the sides of a triangle, which triangles are right triangles?
 - (i) 3, 4, 5
 - (ii) 9, 17, 25
 - (iii) 11, 61, 60
- 6- $\triangle ABC$ is right angled at C . If $m\overline{AC} = 9\text{cm}$ and $m\overline{BC} = 12\text{cm}$, find the length \overline{AB} , using Pythagoras theorem.
- 7- The hypotenuse of a right triangle is 25cm . If one of the sides is of length 24cm , find the length of the other side.
- 8- A ladder 17m long when set against the wall of a house just reaches a window at a height of 15m from the ground. How far is the lower end of the ladder from the base of the wall?
- 9- The two legs of a right triangle are equal and the square of the hypotenuse is 50. Find the length of each leg.
- 10- The sides of a triangle are 15cm , 36cm and 39cm . Show that it is a right angled triangle.

9.2 AREAS

The surface inside the boundary of a shape is called area.

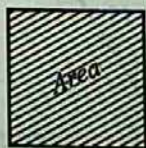

9.2.1 The Area of a Triangle

Area of a Triangle when all the three sides are given

A triangle ABC with sides a, b, c and

$$2S = a + b + c \Rightarrow S = \frac{a + b + c}{2},$$

where 'S' is half the perimeter of a triangle.

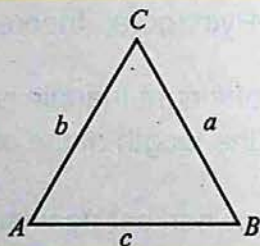

Then area of any triangle is $A = \sqrt{S(S-a)(S-b)(S-c)}$

This is called **Hero's Formula** for finding the area of a triangle.

EXAMPLE Find the area of a triangle whose sides are 5, 12 and 13.

SOLUTION: Given: $a = 5, b = 12, c = 13$ then

$$2S = a + b + c$$

$$2S = 5 + 12 + 13 = 30 \Rightarrow S = 15$$

$$S - a = 15 - 5 = 10,$$

$$S - b = 15 - 12 = 3,$$

$$S - c = 15 - 13 = 2$$

$$A = \sqrt{S(S-a)(S-b)(S-c)}$$

$$= \sqrt{15 \times 10 \times 3 \times 2}$$

$$= \sqrt{900} = 30 \text{ sq. units}$$

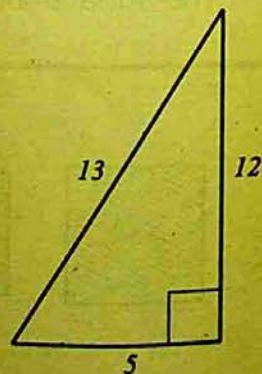

Note:- In this case, the triangle is a right triangle with base 5, altitude 12 and hypotenuse 13.

$$\begin{aligned} \text{Hence area } (A) &= \frac{1}{2} \times (\text{base}) \times (\text{altitude}) \\ &= \frac{1}{2} (5) (12) = \frac{60}{2} \quad A = 30 \text{ square unit.} \end{aligned}$$

Note: Area of a triangle is denoted by A .

Area of a Triangle when base and Altitude are given

Draw any triangle ABC as shown in the figure. Let \overline{BC} be its base and let $\overline{AL} \perp \overline{BC}$. Then \overline{AL} is the corresponding altitude. Through A and C draw line parallel to \overline{BC} and \overline{BA} respectively, intersecting each other at a point D . Then, clearly $ABCD$ is a parallelogram with base \overline{BC} and corresponding altitude \overline{AL} .

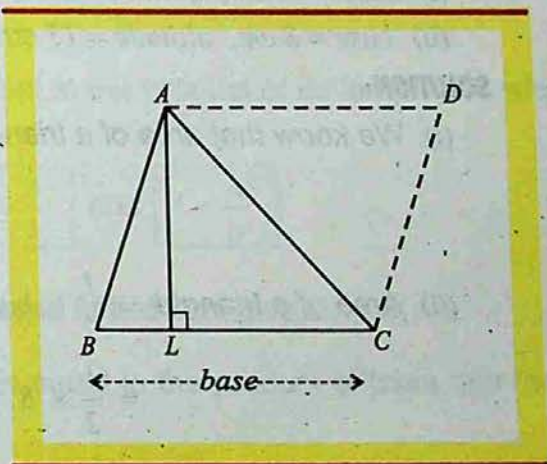

$$\begin{aligned} \text{Area of } \triangle ABC &= \frac{1}{2} (\text{Area of Parallelogram } ABCD) = \frac{1}{2} (\overline{BC} \times \overline{AL}) \\ &= \frac{1}{2} (b \times h) \quad (\text{where } b \text{ is the base and } h \text{ is the altitude.}) \end{aligned}$$

Thus, we have $\text{Area of } \Delta = \frac{1}{2} \times \text{Base} \times \text{Altitude}$

$$\text{Base} = \frac{2 \times \text{Area}}{\text{Altitude}}$$

$$\text{Altitude} = \frac{2 \times \text{Area}}{\text{Base}}$$

IMPORTANT

Altitude of a triangle is its height and denoted by 'h'.

Notation for base is 'b' and 'h' for the altitude.

EXAMPLE-1 Find the altitude of a triangle whose base is 16 cm and area is 34 cm^2

SOLUTION: Altitude of the triangle = $\frac{2 \times \text{Area}}{\text{base}}$

Here area = 34 cm^2 and base = 16 cm

$$\text{Altitude} = \frac{2 \times \text{Area}}{\text{Base}} = \left(\frac{2 \times 34}{16} \right) = 4.25 \text{ cm}$$

IMPORTANT

The side opposite to a right angle in a right angled triangle is its hypotenuse.

EXAMPLE-2 Find the area of triangles whose

(i) base = 18 cm, altitude = 3.5 cm

(ii) base = 8 cm, altitude = 15 cm

SOLUTION:

(i) We know that area of a triangle = $\frac{1}{2} \times \text{base} \times \text{altitude}$

$$= \frac{1}{2} \times 18 \times 3.5 = 31.5 \text{ cm}^2$$

(ii) Area of a triangle = $\frac{1}{2} \times \text{base} \times \text{altitude}$

$$= \frac{1}{2} \times 8 \times 15 = 60 \text{ cm}^2$$

Area of an Equilateral Triangle when its side is given :-

In an equilateral $\triangle ABC$, $a = b = c$.

Therefore, $S = \frac{a+a+a}{2} = \frac{3a}{2}$

$$S-a = \frac{a}{2}, \quad S-b = \frac{a}{2},$$

$$S-c = \frac{a}{2}$$

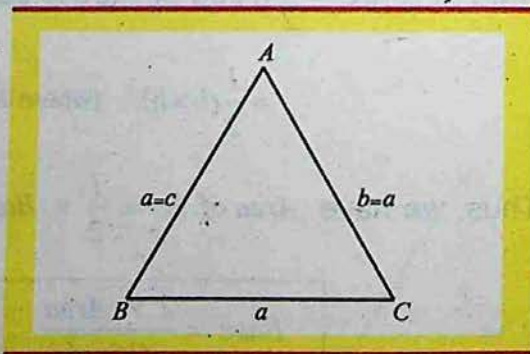

$$\Delta = \sqrt{S(S-a)(S-b)(S-c)} = \sqrt{\frac{3a}{2} \cdot \frac{a}{2} \cdot \frac{a}{2} \cdot \frac{a}{2}} = \frac{\sqrt{3} a^2}{4}$$

Thus area of an equilateral $\triangle ABC$ is $\frac{\sqrt{3} a^2}{4}$

Area of a Rectangle when its two sides are given

Consider a rectangle as shown in the figure.

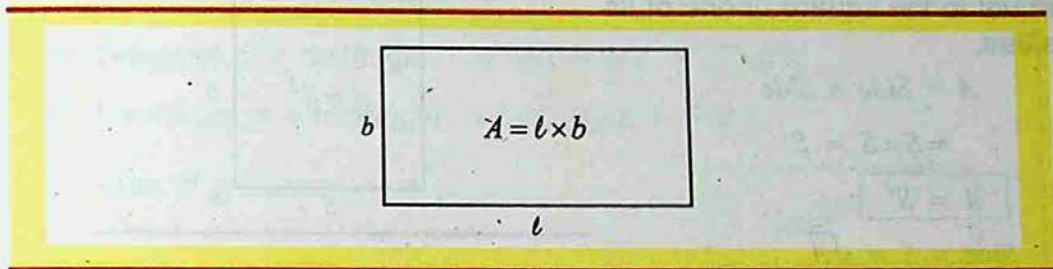

Length of the rectangle = l

Width of the rectangle = b .

The Area of a rectangle is equal to the product of its length and width.

$$A = l \times b$$

Thus $b = \frac{A}{l}$ and $l = \frac{A}{b}$

Area of a Parallelogram when base and Altitude are given:-

The area of a parallelogram is equal to the product of base and the altitude drawn to the base.

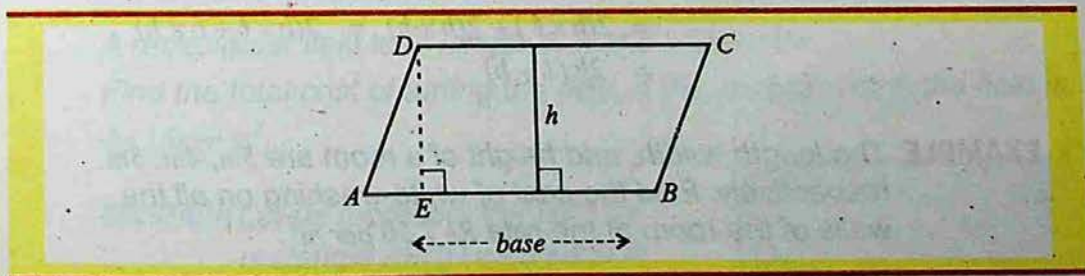

Area of a parallelogram $ABCD = A = \text{base} \times \text{altitude}$

$$A = b \times h$$

$$\text{Base} = b = \frac{A}{h}$$

$$\text{Altitude} = h = \frac{A}{b}$$

IMPORTANT

Area of a triangle:

$$A = \frac{1}{2} \times \text{base} \times \text{altitude}$$

Area of a Square when its side is given:-

The area of a square $ABCD$ is equal to the square of one of its sides.

$$\begin{aligned} A &= \text{Side} \times \text{Side} \\ &= S \times S = S^2 \end{aligned}$$

$$A = S^2$$

$$\text{Side} = S = \sqrt{A}$$

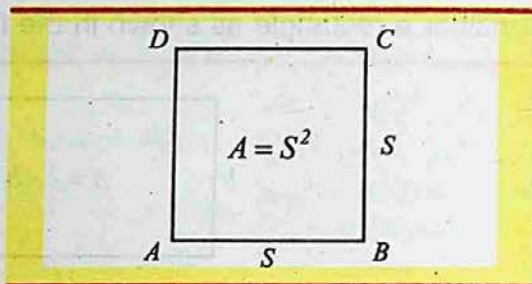

Unit of Area is square unit of length like: cm^2 , m^2 , km^2 .

Area of four Walls of a Room:

We can find the area of four walls of a room when its length, breadth and height are given.

$$\begin{aligned} \text{Let length of the room} &= l \\ \text{Width of the room} &= b \\ \text{Height of the room} &= h \\ \text{Area of four walls} &= h \times l + b \times h + h \times l + b \times h \\ &= 2(h \times l) + 2(b \times h) = 2(h \times l + b \times h) \\ &= 2h(l + b) \end{aligned}$$

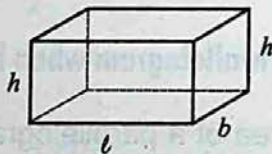

EXAMPLE The length, width, and height of a room are 5m, 4m, 3m respectively. Find the cost of white-washing on all the walls of the room at the rate Rs 7.50 per m^2 .

SOLUTION: Given: $l = 5m$, $b = 4m$, $h = 3m$

$$\begin{aligned} \text{Area of the four walls} &= 2(l + b) \times h = 2(5 + 4) \times 3 \\ &= 18 \times 3 = 54m^2 \end{aligned}$$

Therefore, cost of white-washing at the rate of Rs 7.50/ m^2 = $7.5 \times 54 = \text{Rs } 405$

Things to Remember:

- 1- Area of rectangle = (Length \times Width)
- 2- Diagonal of a rectangle = $\sqrt{(\text{Length})^2 + (\text{Width})^2}$
- 3- Perimeter of a rectangle = $2(\text{Length} + \text{Width})$
- 4- Area of a square = a^2
where a = side of the square
- 5- Diagonal of a square = $\sqrt{2}a$
- 6- Area of a square = $\frac{1}{2}(\text{Diagonal})^2$
- 7- Perimeter of a square = $4 \times \text{Side}$

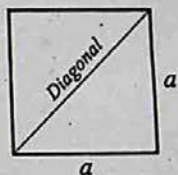
**9.2.2 Areas of Rectangular and Square Fields**

Rectangular paths are generally around (outside or inside) a rectangular field or in the form of central paths. We shall explain the method to calculate their areas through some examples.

EXAMPLE-1

A rectangular field is of length 40m and width 25m.

Find the total cost of turfing the field, if the cost of turfing the field is Rs. 16 per m^2 .

SOLUTION: Let us represent the field by rectangle ABCD as shown in the figure.

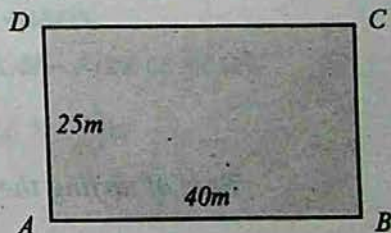

Length of the rectangular field = 40m

Width of the rectangular field = 25m

Area of the rectangular field = $A = l \times b = 40 \times 25 = 1000 m^2$

Rate of turfing = Rs. 16 per m^2

Total cost = $16 \times 1000 = \text{Rs. } 16000$

EXAMPLE-2

The boundary of a square field with side of 60m.
Find the area of the field.
Also find the cost of turfing the square field at
the rate of Rs 5.00 per m^2

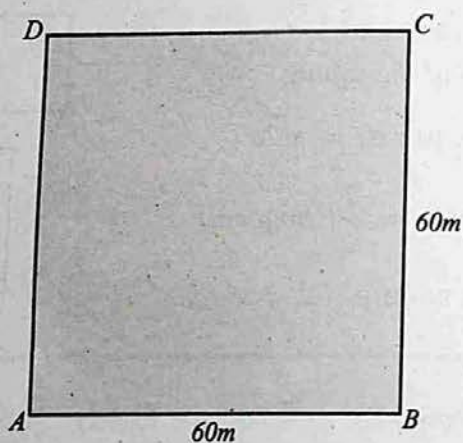
**SOLUTION:**

Let us represent the square field by ABCD as shown in figure.

Length of the side of the square field = 60m

Area of the square = $A = \text{side} \times \text{side}$

$$= 60 \times 60$$

$$= 3600m^2$$

Rate of turfing the square field = Rs. 5 per m^2

\therefore Cost of turfing the square field = 3600×5

$$= 18000 \text{ rupees}$$

9.2.3

EXAMPLE-3

Two cross roads, each 2m wide, run at right angles through the center of a rectangular park of length 72m and width 48m such that each is parallel to one of the sides of the rectangular field. Find the area of the roads. Also find the number of tiles required to beautify this road where each tile having area of 4 m^2 .

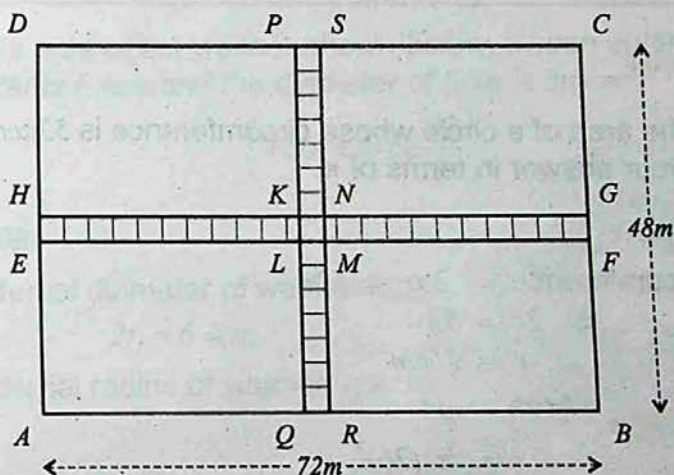
**SOLUTION:**

In figure, rectangular field ABCD represents the park and rectangle PQRS and EFGH represent the roads.

Area of the roads = Area of PQRS + Area EFGH - Area of KLMN

$$= [(48 \times 2) + (72 \times 2) - (2 \times 2)] \text{m}^2$$

$$= (96 + 144 - 4) \text{m}^2$$

$$= 236 \text{ m}^2$$

$$\therefore \text{Number of tiles required} = \frac{236}{4} = 59 \text{ tiles}$$

9.2.4 Area of a Circle

The circumference of circle = $2\pi r$
 where the radius of the
 circle is 'r'.

Area of a circle = πr^2

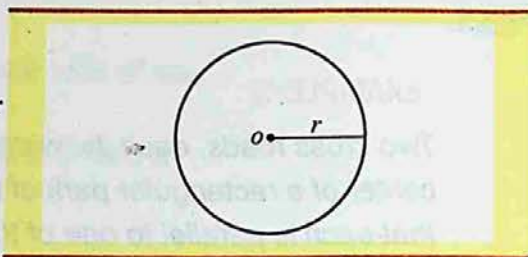

Note: In examples and exercises, where π is not specified, use the value stored in the calculator.

EXAMPLE

Find the area of a circle whose circumference is $52\pi\text{cm}$.
 Give your answer in terms of π .

SOLUTION:

$$\text{Circumference} = 2\pi r = 52\pi$$

$$\Rightarrow 2r = 52$$

$$\Rightarrow r = 26\text{cm}$$

$$\text{Area} = \pi r^2$$

$$= \pi (26)^2$$

$$= 676\pi\text{cm}^2$$

Area of a Semicircle:-

A semicircle is half of a circle,
 bounded by a diameter and half
 of the circumference.

Also a sector with an angle
 of 180° at the center of the circle
 is a semicircle.

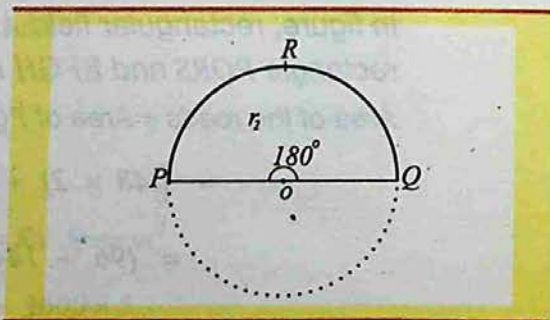

In the figure,

Length of arc $PQ = \frac{1}{2}$ of the circumference of the circle.

Area of sector $PRQ = \frac{1}{2}$ of the area of the circle.

$$\text{Area of semicircle} = \frac{1}{2} (\pi r^2).$$

9.2.5 Area of Concentric Circles

Circles with same center but different radii are called concentric circles. In the figure, c_1, c_2 are two concentric circles with same center 'O' but different radii r_1 and r_2 .

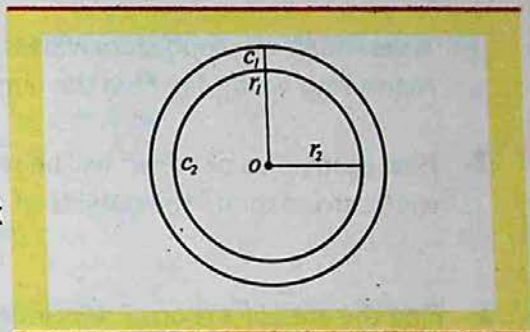

EXAMPLE

Find the area of the washer shown below, whose outer diameter is 6.4cm and the diameter of hole is 3.6cm.

$$\left(\text{Take } \pi \text{ to be } \frac{22}{7} \right)$$

SOLUTION:

External diameter of washer is

$$2r_1 = 6.4 \text{ cm}$$

$$\text{External radius of washer, } r_1 = \frac{6.4}{2}$$

$$r_1 = 3.2 \text{ cm}$$

$$\text{Internal radius of washer} = r_2 = \frac{3.6}{2} = 1.8 \text{ cm}$$

$$\therefore \text{The area of the washer} = \pi r_1^2 - \pi r_2^2$$

$$= \pi (3.2)^2 \text{ cm}^2 - \pi (1.8)^2 \text{ cm}^2$$

$$= \pi [(3.2)^2 - (1.8)^2] \text{ cm}^2$$

$$= \pi (10.24 - 3.24) \text{ cm}^2$$

$$= (\pi \times 7) \text{ cm}^2$$

$$= \frac{22}{7} \times 7 = 22 \text{ cm}^2$$

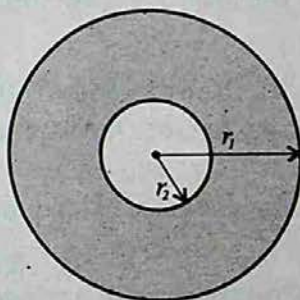

EXERCISE - 9.2

- 1- A verandah $40m$ long, $15m$ wide is to be paved with stones each measuring $6m$ by $5m$. Find the number of stones.
- 2- How many tiles of $40cm^2$ will be required to pave the footpath $1m$ wide carried round the outside of a grassy plot $28m$ by $18m$?
- 3- Find the area of a room $5.49m$ long and $3.87m$ wide. What is the cost of carpeting the room if the rate of carpet is Rs 10.50 per m^2 ?
- 4- The area of a rectangular rice field is 2.5 hectares and its sides are in the ratio $3:2$. Find the perimeter of the field.
- 5- The area of a square playground is $4500 m^2$. How long will a man take to cross it diagonally at the speed of $3km$ per hour ?
- 6- The diagonal of a square is $14cm$. Find its area.
- 7- Find the area of a triangle whose sides are.
 - (i) $120cm$, $150cm$ and $200cm$
 - (ii) $50dm$, $78dm$ and $112dm$
- 8- The perimeter of a triangular field is $540m$ and its sides are in the ratio $25:17:12$. Find the area of the triangle.
 Hint: Let the sides be $25x$, $17x$, $12x$ meters.
 Then $25x + 17x + 12x = 540 \Rightarrow 54x = 540 \Rightarrow x = 10$
 The sides are $250m$, $170m$, $120m$
- 9- Find the area of a parallelogram if its two adjacent sides are $12cm$ and $14cm$ and diagonal is $18cm$.
 Hints:
 Let ABCD is a \parallel^m in which $m\overline{AB} = 12cm$, $m\overline{BC} = 14cm$, $m\overline{AC} = 18cm$
 Find area of ΔABC .
 Area of $\parallel^m = 2(\text{Area of } \Delta ABC)$

10- Find the area of the following washers whose external and internal diameters are:

- (i) 15cm and 13cm (ii) 1.2m and 0.9m
 (iii) 40mm and 33mm .

11- Find the area of the shaded region.

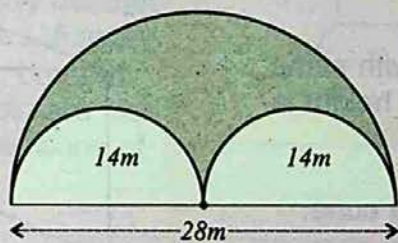

12- Find the area of an equilateral triangle whose side is 8m .

13- The side of an equilateral triangle is 6cm . Find its area.

14- Find the area of the right triangle with legs 12cm and 35cm .

15- The base of a rectangle is three times its altitude. The area is 147cm^2 . Find the dimensions of the rectangle.

16- Find the base of the parallelogram whose altitude is 18cm and whose area is 3m^2 .

17- The area of a parallelogram is 144cm^2 . Find the altitude if the base is 2m long.

18- Find the area of the rectangle 2m long and 18cm wide.

19- The area of an equilateral triangle is $4\sqrt{3}\text{cm}^2$. Find the length of a side.

9.3 VOLUMES

In this topic we study some figures which are not plane. The simplest of these figures are cubes and cuboids. These figures do not lie completely in a plane, such figures are called solids, (three dimensional figures).

Cube and Cuboid

Cube :-

A six faces figure, with same length, breadth and height is called a cube.

The given figure is a cube,

Length of the cube = l

Breadth of the cube = b

Height of the cube = h

where $l = b = h$,

therefore,

$$\begin{aligned} \text{Volume of a cube} &= V = l \times l \times l \\ \text{or } V &= l^3 \text{ cubic unit} \end{aligned}$$

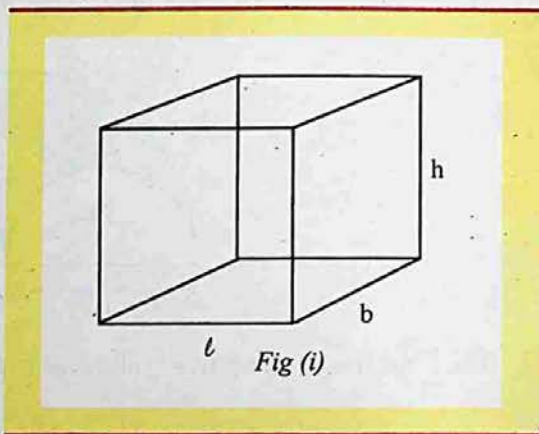

EXAMPLE

Find the volume of the cube whose edge is 8m.

SOLUTION:

Given edge of the cube = 8m

$$\text{Volume} = l^3$$

$$V = 8 \times 8 \times 8 = 8^3$$

$$V = 512 \text{ m}^3$$

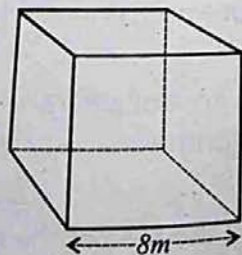

Dimensions:

Length has one dimension.

Area has two dimensions.

Volume has three dimensions.

Cuboid :-

A six faces figure which has length, breadth and height is called cuboid,
(or *rectangular parallelepiped*).

Figure (ii) represents a cuboid.

The length, breadth and height of a cuboid are usually denoted by the letter symbols l , b , and h respectively. Length, breadth and height of a cuboid are also called the three dimensions of the cuboid.

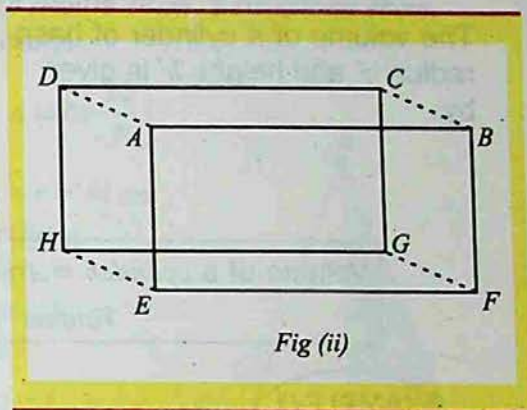

Fig (ii)

Volume of a cuboid of length l , breadth b and height h is

$$V = l \times b \times h$$

EXAMPLE

Find the volume of a block of wood whose length, breadth and height are respectively 10cm, 5cm and 3cm.

SOLUTION:

Given:

Length of the block of wood = 10cm

Breadth of the block of wood = 5cm

Height of the block of wood = 3cm

$$\begin{aligned} V &= l \times b \times h \\ &= 10 \times 5 \times 3 \\ &= 150 \text{ cm}^3 \end{aligned}$$

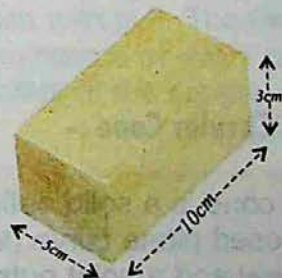
**Volume of a Cuboid and a Cube :-**

- 1- Length, breadth and height must be expressed in the same units.
- 2- From above formula, we also observe that:

$$\text{Length } l = \frac{v}{b \times h}$$

$$\text{Breadth } b = \frac{v}{l \times h}$$

$$\text{Height } h = \frac{v}{l \times b}$$

Volume of Right Circular Cylinder :-

The volume of a cylinder of base radius ' r ' and height ' h ' is given by.

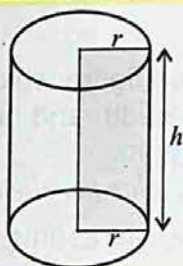

$$\text{Volume of a cylinder} = \text{Area of base} \times \text{height} = \pi r^2 \times h$$

$$\text{Volume} = \pi r^2 h$$

EXAMPLE-1

Find the radius of the cylinder with volume 12320 cm^3 and height 20 cm .

SOLUTION: Given $v = 12320 \text{ cm}^3$, $h = 20 \text{ cm}$, $r = ?$

$$v = \pi \times r^2 \times h \Rightarrow r^2 = \frac{v}{\pi h}$$

$$r^2 = \frac{12320}{\frac{22}{7} \times 20} = \frac{12320 \times 7}{22 \times 20} = \frac{616 \times 7}{22} = 196$$

$$r = 14 \text{ cm}$$

Right Circular Cone :-

A cone is a solid defined by a closed plane curve (forming the base) and a point outside the plane (the vertex). A right circular cone can be generated by rotating the right-angled triangle BOA as shown in fig(i) about \overline{OB} , which represents the height of the cone. The base of the cone is a circle with radius \overline{OA} .

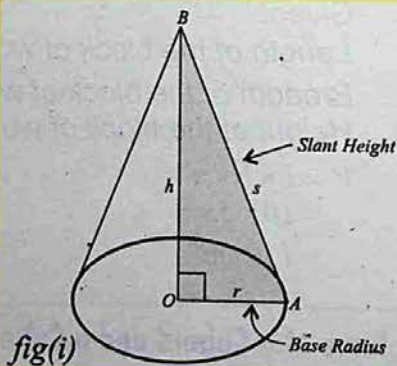

B is the vertex of the cone and \overline{BA} is the slant height.

Volume of a cone = $\frac{1}{3} \times \text{area of base} \times \text{height}$

$$\text{Volume of a cone} = v = \frac{1}{3} \pi r^2 \times h$$

EXAMPLE

A cone has a circular base of radius 14cm, a height of 48cm, calculate the volume of the cone.

SOLUTION:

(Take π to be $\frac{22}{7}$)

Given radius of the base = $r = 14$ cm

Height of the cone = $h = 48$ cm

$$\begin{aligned} \text{Volume of the cone} &= \frac{1}{3} \pi r^2 h \\ &= \frac{1}{3} \times \frac{22}{7} \times (14)^2 \times 48 \\ &= \frac{1}{3} \times \frac{22}{7} \times 196 \times 48 \\ &= 9856 \text{ cm}^3 \end{aligned}$$

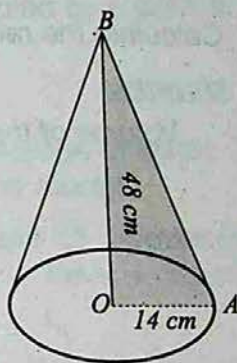
**Sphere :-**

A sphere is a body or space bounded by surface where every point on the surface is equidistant from a fixed point within it. The fixed point is called the center of the sphere. The distance of every point on the surface to the fixed point is called the radius of the sphere. This radius is usually denoted by ' r '.

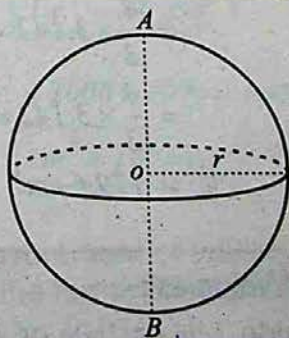

$$\text{Volume of the sphere} = \frac{2}{3} \times 2\pi r^3$$

$$V = \frac{4}{3} \pi r^3, \text{ where } r \text{ is the radius of the sphere.}$$

Hemispheres :-

If a sphere is cut into half, the two portions are called hemispheres.

EXAMPLE-1

Calculate the radius of a sphere of volume 850 m^3 take π to be $\frac{22}{7}$

SOLUTION:

$$\text{Volume of the a sphere} = 850 \text{ m}^3$$

$$\text{Radius} = ?$$

$$\text{Now} \quad V = \frac{4}{3} \pi r^3$$

$$r^3 = \frac{3V}{4\pi} \Rightarrow r^3 = \frac{3 \times 850 \times 7}{4 \times 22}$$

$$\Rightarrow r^3 = 202.8409$$

$$\Rightarrow r = (202.8409)^{\frac{1}{3}} = 5.88 \text{ m}$$

EXAMPLE-2

Find the volume of a sphere with radius 3.5 cm .

SOLUTION:

$$\text{Radius of a sphere} = r = 3.5 \text{ cm}$$

$$\text{Volume of a sphere} = V = \frac{4}{3} \pi r^3$$

$$= \frac{4}{3} \times 3.142 \times (3.5)^3$$

$$= \frac{4}{3} \times 3.142 \times 3.5 \times 3.5 \times 3.5$$

$$V = 179.6 \text{ cm}^3$$

Some Standard Units of Volumes :-

If we take a cube of side 1 cm or 1 mm or 1 m as a standard unit of measuring volumes, then we express the volume as:

$$\text{cubic centimeters: } (\text{cm})^3$$

$$\text{cubic millimeters: } (\text{mm})^3$$

$$\text{cubic meters: } (\text{m})^3$$

Real Life Problems Related to Volume

A solid region has a magnitude or size or measure. The measure or magnitude of a solid region is called its volume.

In other words, the measure of the space occupied by a solid is called its volume.

For example, consider the real life problems.

1. A rectangular overhead tank is built for storage of water. The greater the volume the more water can be stored.
2. A rectangular tin box is to be made to store oil. The greater the volume of the cuboidal region, the more is the quantity of oil it can store.

Remember that:

1- As $1\text{cm} = 10\text{mm}$,

Therefore, $1\text{cm}^3 = 10 \times 10 \times 10 \text{mm}^3$

$$1\text{cm}^3 = 1000 \text{mm}^3$$

2- $1\text{m}^3 = 100 \times 100 \times 100 \text{cm}^3$

$$= 1000000 \text{cm}^3$$

$$1\text{m}^3 = 10^6 \text{cm}^3$$

Also $1\text{m}^3 = 1000 \times 1000 \times 1000 \text{mm}^3$

$$1\text{m}^3 = 10^9 \text{mm}^3$$

- 3- For measurement of volumes of liquids, we use the terms liters (ℓ) and milliliters (ml).

$$1\text{cm}^3 = 1\text{ml}$$

$$1000 \text{cm}^3 = 1\ell$$

and $1\text{m}^3 = 1000000 \text{cm}^3 = 1000 \ell$

$$1\text{m}^3 = 1\text{k}\ell \text{ (1 kiloliter)}$$

EXAMPLE-1

Find in liters, the volume (capacity) of a storage tank whose length, breadth and depth are respectively 6.3m, 4.5m and 3.6m.

SOLUTION:

$$\text{Length of the tank} = 6.3 \text{ m}$$

$$\text{Breadth of the tank} = 4.5 \text{ m}$$

$$\text{Height of the tank} = 3.6 \text{ m}$$

$$\text{Volume of the tank} = \ell \times b \times h = 6.3 \times 4.5 \times 3.6 \text{ m}^3$$

$$= 102.06 \text{ m}^3$$

$$\text{Volume of the tank (m}^3\text{)} = 102.06 \times 100 \times 100 \times 100$$

$$= 102060000 \text{ cm}^3$$

$$= 102060 \text{ litres } (\because 1000 \text{ cm}^3 = 1 \text{ litre})$$

EXAMPLE-2

Capacity of a tank is 60kl. If the length, breadth of the tank are respectively 5m, and 4m, find its depth.

SOLUTION:

$$\text{Volume of the tank} = 60 \text{ kl} = 60000 \text{ liter} = 60 \text{ m}^3$$

$$\text{Length of the tank} = 5 \text{ m}$$

$$\text{Breadth of the tank} = 4 \text{ m}$$

$$\text{Let depth of the tank} = d$$

$$\text{Now, volume of the tank} = \text{length} \times \text{breadth} \times \text{depth}$$

$$\text{Therefore, depth of the tank} = \frac{\text{volume}}{\text{length} \times \text{breadth}}$$

$$= \frac{60}{20} (\because 60000 \text{ lt} = 60 \text{ m}^3)$$

$$= 3 \text{ m}$$

EXERCISE - 9.3**Find the Volume of the Solids**

- 1- A cube of a side 4cm .
- 2- A cube whose total area is 96cm^2 .
- 3- A rectangular box with length 4m breadth 3m and height 2m .
- 4- Right cylinder, with radius of base 4cm , altitude 10cm , use $\pi = \frac{22}{7}$.
- 5- Circular cone, with radius of base 3cm , altitude 10cm .
- 6- Sphere, with radius 3cm .
- 7- Right circular cylinder, with circumferences of base 4cm , altitude 1m .
- 8- Cone with altitude 9cm , radius of base 6cm .

Review Exercise-9**I- Encircle the Correct Answer.**

1. If the square of the hypotenuse of a right triangle is equal to the sum of the squares of the other sides, it is called:

(a) <i>Pythagoras theorem</i>	(b) <i>Scalene triangle</i>
(c) <i>Equilateral triangle</i>	(d) <i>Isosceles triangle</i>
2. Area of a triangle when all the three sides are given is:

(a) $\frac{1}{2}bh$	(b) bh
(c) $\sqrt{s(s-a)(s-b)(s-c)}$	(d) $\frac{a+b+c}{2}$
3. Area of an equilateral triangle with side ' a ' is:

(a) $\frac{1}{2}bh$	(b) bh	(c) $\frac{\sqrt{3}a^2}{4}$	(d) $\frac{\sqrt{3}a^2}{2}$
---------------------	----------	-----------------------------	-----------------------------

Review Exercise-9

4. Area of a rectangle is:

(a) $l \times b$

(b) $\frac{l}{2} \times l + b$

(c) $\frac{l}{3} \times l + b$

(d) l^2

5. Area of a square with side ' S ' is:

(a) S

(b) $4S$

(c) $2S$

(d) S^2

6. Area of a circle with radius ' r ' is:

(a) r^2

(b) $2\pi r$

(c) πr^2

(d) $\pi^2 r$

7. Area of a semi-circle is:

(a) $\frac{\pi r^2}{2}$

(b) πr^2

(c) $\pi^2 r$

(d) $2\pi r$

8. Volume of a cube with edge ' l ' is:

(a) l^2

(b) $3l$

(c) l^3

(d) l^4

9. Volume of a right circular cylinder is:

(a) $\frac{\pi r^2 h}{3}$

(b) $\frac{\pi r^2 h}{2}$

(c) $\pi r^2 h$

(d) $\frac{4}{3} \pi r^2$

II- Fill in the blanks.

1. If the square of the hypotenuse of a right triangle is equal to sum of the squares of the sides, then it is called _____ theorem.
2. The surface inside the boundary of a shape is called _____.
3. Area of a triangle = _____.
4. Hero's formula for a triangle is $A =$ _____.
5. An equilateral triangle with side ' a ' has area = _____.
6. Area of a rectangle = _____.

7. Area of a circle = _____.
8. Volume of a cube with edge 'l' is _____.
9. Volume of a cuboid = _____.
10. Volume of a right circular cone = _____.

SUMMARY

Pythagoras Theorem: The square of the hypotenuse of a right triangle is equal to the sum of the squares of the legs.

Area: The space inside the boundary of a shape.

Area of a Triangle: $A = \frac{1}{2} \times \text{base} \times \text{altitude}$

Area of a Triangle: $A = \sqrt{s(s-a)(s-b)(s-c)}$

$$s = \frac{a+b+c}{2}, a, b, c \text{ are the sides of a triangle.}$$

Area of an equilateral triangle: $A = \frac{\sqrt{3}a^2}{4}$, where 'a' is the side of the triangle.

Area of a rectangle: $A = \text{length} \times \text{breadth}$.

Area of a square: $A = \text{side} \times \text{side}$.

Area of a parallelogram: $A = \text{base} \times \text{altitude}$.

Area of a circle: $A = \pi r^2$

Circumference of a circle: $C = 2 \pi r$

Area of a semi-circle: $A = \frac{1}{2}(\pi r^2)$

Area of a washer: $A = \pi [r_1^2 - r_2^2]$

r_1 is the radius of outer circle.

r_2 is the radius of inner circle.

Volume: The space inside the boundary of a three dimensional shape.

Volume of a cube: $V = l^3$, l is the length of edge.

Volume of a cuboid: $V = l \times b \times h$

$l = \text{length}$, $b = \text{breadth}$, $h = \text{height}$

Volume of a right circular cylinder: $V = \pi r^2 h$

$h = \text{height of the cylinder}$

$r = \text{radius of the base}$

Volume of a right circular cone: $V = \frac{1}{3} \pi r^2 h$

$h = \text{height of the cone}$

$r = \text{radius of the base}$

Volume of sphere: $V = \frac{4}{3} \pi r^3$

Volume of a hemi-sphere: $V = \frac{2}{3} \pi r^3$

UNIT

10

INTRODUCTION TO COORDINATE GEOMETRY

- ▶ Introduction To Coordinate Geometry
- ▶ Distance Formula
- ▶ Collinear Points

After completion of this unit, the students will be able to:

- ▶ define coordinate geometry.
- ▶ derive distance formula to find distance between two points given in cartesian plane.
- ▶ use distance formula to find distance between two given points.
- ▶ define collinear points.
- ▶ distinguish between collinear and non-collinear points.
- ▶ use distance formula to show that given three (or more) points are collinear.
- ▶ use distance formula to show that the given three non-collinear points form:
 - An equilateral triangle.
 - An isosceles triangle.
 - A right angled triangle.
 - A scalene triangle.

10.1 DISTANCE FORMULA

In 17th Century, Descartes, a French Mathematician introduced a plane. A set of infinite number of points, called Cartesian Plane. Every point in a plane can be located in terms of a pair of numbers related to two number axes in the plane, which are perpendicular to each other and intersect at the origin.

The plane is called a cartesian plane, and the axes are designated the horizontal (\overline{OX}) and vertical (\overline{OY}) axes, or the x -axis and the y -axis.

axes divide the plane into four quadrants shown in the figure.

in the plane and a line through P is parallel to the y -axis, the lines will intersect the x -axis at two points, M and N . The coordinate of $M(m)$

on the x -axis is called the x -coordinate or abscissa of P , and the coordinate of $N(n)$ on the y -axis is called the y -coordinate or ordinate of P .

The two numbers (m,n) are called the coordinates of P with respect to the coordinate axes. The letters m and n stand for numbers, and since the x -coordinate is always written first, such a pair is called an ordered pair of numbers. That is, the pair $(3,2)$ is not the same as the pair $(2,3)$.

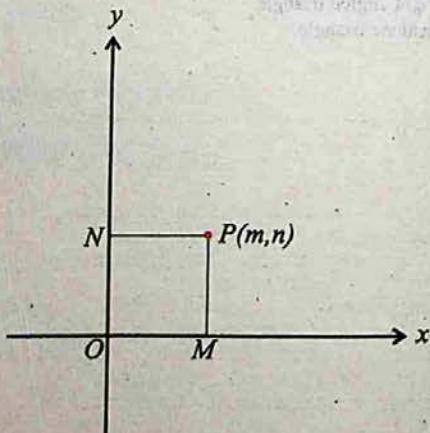
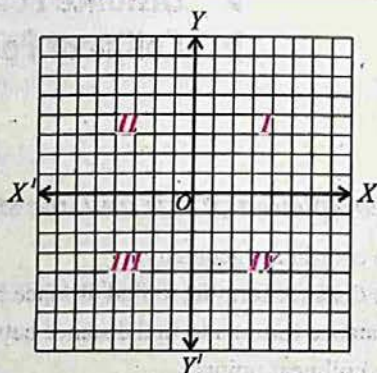

Remember that:

- (i) A point in a number plane determines a unique ordered pair of numbers.
- (ii) With every ordered pair of numbers a unique point is associated in the plane.

Since numbers to the right of the origin on the horizontal axis and numbers above the origin on the vertical axis are taken as positive, therefore:

- (i) A point in the *Ist* quadrant is characterized by the fact that both its coordinates are positive.
- (ii) A point in the *IInd* quadrant has its abscissa negative and its ordinate positive.
- (iii) A point in the *IIIrd* quadrant has both coordinates negative.
- (iv) A point in the *IVth* quadrant has its abscissa positive and its ordinate negative.
- (v) Points on the axes do not lie in any quadrant.
- (vi) Points on the positive x -axis have a positive abscissa, and their ordinate is "0".
- (vii) Points on the negative x -axis have a negative abscissa, and their ordinate is "0".
- (viii) Points on the positive y -axis have a positive ordinate, and abscissa is "0".
- (ix) Points on the negative y -axis have a negative ordinate, and their abscissa is "0".
- (x) The origin has the coordinates $(0, 0)$.

EXAMPLE-1

Locate $(2, -4)$ in the co-ordinate plane.

SOLUTION:

In this problem abscissa is positive, therefore it would be towards the right of the origin, and the ordinate is negative, so it would be below the origin, therefore the given point P is as shown in the figure.

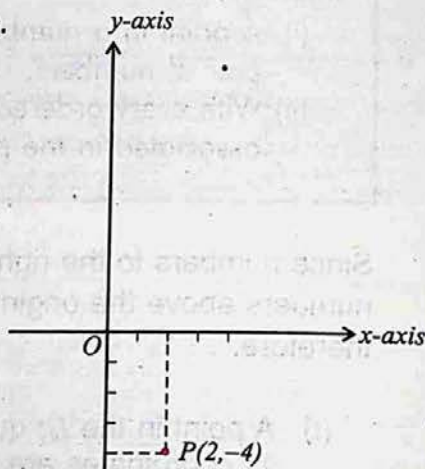
**10.1.2 Distance Between Two Points**

Consider the points $P(x_1, y_1)$ and $Q(x_2, y_2)$ in the cartesian plane as shown in the figure. To find the length of the segment \overline{PQ} , we form a right triangle by drawing through P a line parallel to x -axis and through Q a line parallel to y -axis and let these lines meet at $R(x_2, y_1)$.

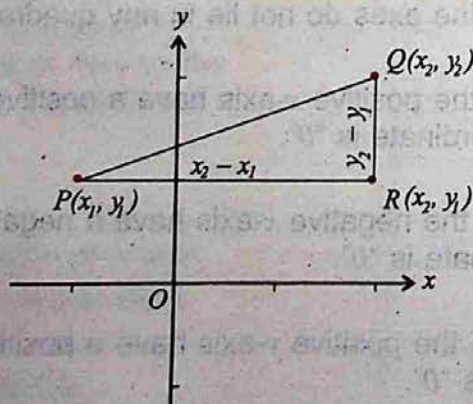

By Pythagoras theorem, we have.

$$|\overline{PQ}|^2 = |\overline{PR}|^2 + |\overline{RQ}|^2$$

$$\begin{aligned} |\overline{PQ}|^2 &= |(x_2 - x_1)|^2 + |(y_2 - y_1)|^2 \\ &= (x_2 - x_1)^2 + (y_2 - y_1)^2 \end{aligned}$$

$$\text{Hence } |\overline{PQ}| = \pm \sqrt{(x_2 - x_1)^2 + (y_2 - y_1)^2}$$

As we are only interested in the length of the segment and not in the direction, therefore we only consider the positive sign.

Hence distance between two points $P(x_1, y_1)$ and $Q(x_2, y_2)$ is given by:

$$d = |\overline{PQ}| = \sqrt{(x_2 - x_1)^2 + (y_2 - y_1)^2}$$

10.1.3 Use of Distance Formula

EXAMPLE-1

What kind of a triangle has vertices $A(6, -2)$, $B(1, -2)$ and $C(-2, 2)$?

SOLUTION:

Given $A(6, -2)$, $B(1, -2)$ and $C(-2, 2)$. Using distance formula,

$$|\overline{AB}| = \sqrt{(1-6)^2 + (-2+2)^2} = \sqrt{5^2 + 0} = \sqrt{25} = 5$$

$$|\overline{AC}| = \sqrt{(-2-6)^2 + (2+2)^2} = \sqrt{8^2 + 4^2} = \sqrt{64+16} = \sqrt{80} = 4\sqrt{5}$$

$$|\overline{BC}| = \sqrt{(-2-1)^2 + (2+2)^2} = \sqrt{3^2 + 4^2} = \sqrt{9+16} = \sqrt{25} = 5$$

$$\text{Since } |\overline{AB}| = |\overline{BC}| = 5$$

Thus, triangle is an isosceles.

EXAMPLE-2

Express by an equation the fact that the distance from $P(x,y)$ to $A(2,3)$ is twice the distance from $P(x,y)$ to $B(3,4)$

SOLUTION:

Given $A(2,3)$, $B(3,4)$ and $P(x,y)$, where $P(x,y)$ be any point, According to the condition of the question.

$$|AP| = 2 |BP|, \text{ using distance formula.}$$

$$\sqrt{(x-2)^2 + (y-3)^2} = 2\sqrt{(x-3)^2 + (y-4)^2}$$

Taking square on both sides

$$(x-2)^2 + (y-3)^2 = 4[(x-3)^2 + (y-4)^2]$$

$$x^2 - 4x + 4 + y^2 - 6y + 9 = 4[x^2 - 6x + 9 + y^2 - 8y + 16]$$

$$x^2 + y^2 - 4x - 6y + 13 = 4x^2 + 4y^2 - 24x - 32y + 100$$

$$3x^2 + 3y^2 - 20x - 26y + 87 = 0$$

EXAMPLE-3

The vertices of a triangle are $A(1,1)$, $B(5,5)$ and $C(9,1)$. Prove that the triangle is a right triangle.

SOLUTION:

Given $A(1,1)$, $B(5,5)$ and $C(9,1)$. using distance formula,

$$|AB| = \sqrt{(5-1)^2 + (5-1)^2} = \sqrt{4^2 + 4^2} = \sqrt{32}$$

$$|AC| = \sqrt{(9-1)^2 + (1-1)^2} = \sqrt{8^2} = \sqrt{64}$$

$$|BC| = \sqrt{(9-5)^2 + (1-5)^2} = \sqrt{4^2 + 4^2} = \sqrt{32}$$

By Pythagoras theorem,

$$\begin{aligned} |AB|^2 + |BC|^2 &= 32 + 32 \\ &= 64 \\ &= |AC|^2 \end{aligned}$$

Thus ΔABC is a right triangle.

10.2 COLLINEAR POINTS

10.2.1 Collinear Points

Collinear points are points which are the elements of the set of points forming a straight line.

In the given figure (i) the points A, B, C, D, \dots are collinear. If three points are collinear, then one of the points must be lying in between the other two points.

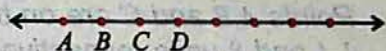

Fig (i)

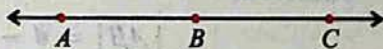

Fig (ii)

In the figure (ii) 'B' is the point in between the point A and C.

In this case, $|AB| + |BC| = |AC|$.

10.2.2 Collinear and Non-Collinear Points

A line-segment is a subset of a line, consisting of two end points and the set of infinite number of points between them on the line.

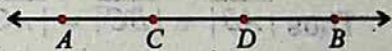

In the given figure, \overline{CD} is the line-segment which is a sub-set of a line AB (or \overline{AB}). The point C and D are on the line AB and are collinear.

The three or more than three points which are not present on the same straight line are called non-collinear points.

In the given figure P, Q and R are non-collinear points.

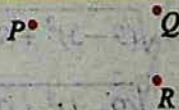

Remember that:

In the figure P, Q, R are non-collinear points.

- (i) Two points are always collinear.
- (ii) Three points may or may not be collinear.

10.2.3 Collinearity of Three Points

EXAMPLE-1

Points A, B and C are on the number line at a distance of 1, 4 and 8 units respectively from the origin.

Find \overline{AB} , \overline{BC} and \overline{AC} , and show that $\overline{AB} + \overline{BC} = \overline{AC}$

SOLUTION:

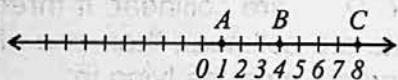

$$|\overline{AB}| = 4 - 1$$

$$|\overline{AB}| = 3$$

$$|\overline{BC}| = 8 - 4 = 4$$

$$|\overline{AC}| = 8 - 1 = 7$$

$$\text{Now } |\overline{AB}| + |\overline{BC}| = 3 + 4$$

$$= 7 = |\overline{AC}|$$

$$\text{Thus } |\overline{AB}| + |\overline{BC}| = |\overline{AC}|$$

EXAMPLE-2

Show that the points $A(1,4)$, $B(5,6)$ and $C(9,8)$ are collinear.

SOLUTION:

Given $A(1,4)$, $B(5,6)$ and $C(9,8)$.

Using distance formula, we have.

$$|\overline{AB}| = \sqrt{(5-1)^2 + (6-4)^2} = \sqrt{4^2 + 2^2} = \sqrt{20} = 2\sqrt{5}$$

$$|\overline{BC}| = \sqrt{(9-5)^2 + (8-6)^2} = \sqrt{4^2 + 2^2} = \sqrt{20} = 2\sqrt{5}$$

$$|\overline{AC}| = \sqrt{(9-1)^2 + (8-4)^2} = \sqrt{8^2 + 4^2} = \sqrt{80} = 4\sqrt{5}$$

$$\text{Now } |\overline{AB}| + |\overline{BC}| = 2\sqrt{5} + 2\sqrt{5}$$

$$= 4\sqrt{5}$$

$$= |\overline{AC}|$$

Thus, the points A, B , and C are collinear.

EXAMPLE-3

Show that the points $A(4,3)$, $B(-2,3)$ and $C(-6,3)$ are collinear.

SOLUTION:

Given $A(4,3)$, $B(-2,3)$ and $C(-6,3)$.

Using distance formula, we have.

$$|AB| = \sqrt{(-2-4)^2 + (3-3)^2} = \sqrt{36+0} = 6$$

$$|BC| = \sqrt{(-6-2)^2 + (3-3)^2} = \sqrt{16+0} = 4$$

$$|AC| = \sqrt{(-6-4)^2 + (3-3)^2} = \sqrt{100} = 10$$

$$\text{Now } |AB| + |BC| = 6 + 4$$

$$= 10$$

$$= |AC|$$

Thus, the points A, B , and C are collinear.

10.2.4 Use of Distance Formula (for The Non-collinear Points)

We use the distance formula to show that the given three non-collinear points form:-

- ▶ a right angle triangle
- ▶ an isosceles triangle
- ▶ an equilateral triangle
- ▶ a scalene triangle

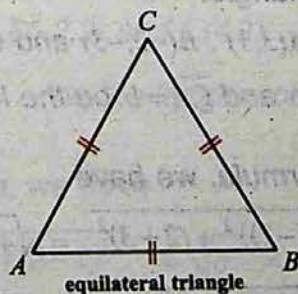
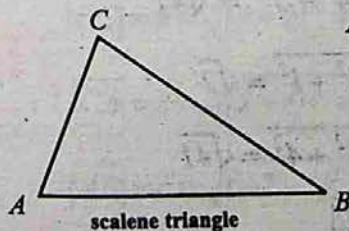

equilateral triangle

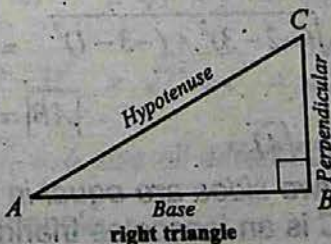

right triangle

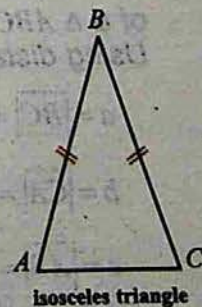

isosceles triangle

EXAMPLE-1

Show that the points $A(-1,2)$, $B(7,5)$ and $C(2,-6)$ are vertices of a right triangle.

SOLUTION: Given $A(-1,2)$, $B(7,5)$, $C(2,-6)$.

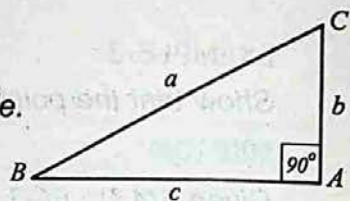

Let a, b, c denote the lengths of the sides \overline{BC} , \overline{CA} , and \overline{AB} respectively of ΔABC , using distance formula

$$|PQ| = \sqrt{(x_2 - x_1)^2 + (y_2 - y_1)^2}$$

we have

$$a = |\overline{BC}| = \sqrt{(2-7)^2 + (-6-5)^2} = \sqrt{5^2 + 11^2} = \sqrt{146}$$

$$b = |\overline{CA}| = \sqrt{(2-(-1))^2 + (-6-2)^2} = \sqrt{3^2 + 8^2} = \sqrt{73}$$

$$c = |\overline{AB}| = \sqrt{(7-(-1))^2 + (5-2)^2} = \sqrt{(8)^2 + (3)^2} = \sqrt{64+9} = \sqrt{73}$$

$$\text{clearly } |\overline{AB}|^2 + |\overline{CA}|^2 = c^2 + b^2$$

$$= 73 + 73 = 146 = a^2$$

$$= |\overline{BC}|^2$$

Thus, ΔCAB , is a right triangle with right angle at A .

EXAMPLE-2

Show that the points $A(3,1)$, $B(-2,-3)$ and $C(2,2)$ are vertices of an Isosceles triangle.

SOLUTION: Given $A(3,1)$, $B(-2,-3)$ and $C(2,2)$.

Let $\overline{AB} = c$, $\overline{BC} = a$ and $\overline{CA} = b$ be the lengths of the sides of a ΔABC .

Using distance formula, we have

$$a = |\overline{BC}| = \sqrt{(2-(-2))^2 + (2+3)^2} = \sqrt{4^2 + 5^2} = \sqrt{41}$$

$$b = |\overline{CA}| = \sqrt{(3-2)^2 + (1-2)^2} = \sqrt{1^2 + 1^2} = \sqrt{2}$$

$$c = |\overline{AB}| = \sqrt{(-2-3)^2 + (-3-1)^2} = \sqrt{5^2 + 4^2} = \sqrt{41}$$

$$|\overline{AB}| = |\overline{BC}|$$

$$\text{Here } c = a = \sqrt{41}$$

That is, the two sides are equal in length.

Thus, ΔABC is an Isosceles triangle.

EXAMPLE-3

Show that the points $A(-3,0)$, $B(3,0)$ and $C(0,3\sqrt{3})$ are the vertices of an equilateral triangle.

SOLUTION: Given $A(-3,0)$, $B(3,0)$ and $C(0,3\sqrt{3})$.

Using distance formula, we have,

$$|AB| = \sqrt{(-3-3)^2 + (0-0)^2} = \sqrt{(-6)^2} = \sqrt{36} = 6$$

$$|BC| = \sqrt{(3-0)^2 + (0-3\sqrt{3})^2} = \sqrt{9+27} = \sqrt{36} = 6$$

$$|AC| = \sqrt{(-3-0)^2 + (0-3\sqrt{3})^2} = \sqrt{9+27} = \sqrt{36} = 6$$

Here $|AB| = |BC| = |AC| = 6$

That is, three sides of ΔABC are equal in length.

Thus, ΔABC is an equilateral triangle.

EXAMPLE-4

Show that the points $A(5,3)$, $B(-2,2)$ and $C(4,2)$ are vertices of a scalene triangle.

SOLUTION: Given $A(5,3)$, $B(-2,2)$ and $C(4,2)$.

Let $\overline{BC} = a$, $\overline{CA} = b$, $\overline{AB} = c$ be the lengths of the sides of a ΔABC .

Using distance formula, we have

$$|BC| = a = \sqrt{(4+2)^2 + (2-2)^2} = \sqrt{6^2} = 6$$

$$|CA| = b = \sqrt{(5-4)^2 + (3-2)^2} = \sqrt{1^2 + 1^2} = \sqrt{2}$$

$$|AB| = c = \sqrt{(-2-5)^2 + (2-3)^2} = \sqrt{7^2 + 1^2} = \sqrt{50} = 5\sqrt{2}$$

As, $|AB| = c$, $|BC| = a$, $|CA| = b$ are all different in length.

Thus ΔABC is a scalene triangle.

EXERCISE - 10.1

- 1- Describe the location of these points on the number plane.

(i) $(1,0)$	(ii) $(0,4)$	(iii) $(-2,4)$	(iv) $(3,6)$
(v) $(-4,0)$	(vi) $(-8,-8)$	(vii) $(7,-5)$	(viii) $(-8,10)$
(ix) $(0,-7)$	(x) $(8,-3)$		

- 2- Find the distance between the following pairs of points.

(i) $(2,1), (-4,3)$	(ii) $(-1,3), (-2,-1)$
(iii) $(7,-2), (-2,3)$	(iv) $(a,-b), (b,-a)$

- 3- Express by an equation, the fact, that the point $P(x,y)$ is equidistant from $A(2,4)$ and $B(6,8)$.

- 4- Show that the points $A(5,4)$, $B(4,-3)$, $C(-2,5)$ are equidistant from $D(1,1)$.

- 5- Find the point on the x -axis which is equidistant from $(2,4)$ and $(6,8)$.
(Hint: call the point $(x,0)$. Find x .)

- 6- Show that the points $A(0,2)$, $B(3,-2)$ and $C(0,-2)$ are vertices of a right triangle.

- 7- Show that the points $A(-1,1)$, $B(3,2)$, $C(7,3)$ are collinear.

- 8- Show that the points $A(6,1)$, $B(2,7)$ and $C(-6,-7)$ are vertices of a right triangle.

- 9- Show that the points $A(2,4)$, $B(6,2)$, $C(4,3)$ are collinear.

- 10- Show that the points $A(4,-2)$, $B(-2,4)$ and $C(5,5)$ are vertices of an isosceles triangle.

- 11- Show that the points $A(-2,11)$, $B(-6,-3)$ and $C(4,-9)$ are of a scalene triangle.

- 12- Show that the points $A(6,1)$, $B(2,7)$ and $C(-6,7)$ are of a scalene triangle.

- 13- Show that the points $A(2,-5)$, $B(-4,-3)$ and $C(-1,5)$ are of an equilateral triangle.

Review Exercise-10

I- Encircle the Correct Answer.

- $d = \sqrt{(x_2 - x_1)^2 + (y_2 - y_1)^2}$ is called
(a) distance formula (b) collinear points
(c) non-collinear points (d) equal points
- A point in a cartesian plane determines a unique ordered pair of:
(a) set (b) abscissa (c) numbers (d) ordinate
- In the plane with every ordered pair is associated:
(a) a unique point (b) zero (c) two points (d) four points
- Points lying on the same line are called:
(a) non-collinear (b) collinear (c) equal (d) overlapping
- Points which do not lie on the same straight line are called:
(a) non-collinear (b) collinear (c) equal (d) zero
- Point on the axis do not lie in any:
(a) a plane (b) line (c) quadrant (d) circle
- The co-ordinates of the origin are:
(a) 0 (b) (1,0) (c) (0,0) (d) (0,1)
- Points on the negative x -axis have negative:
(a) abscissa (b) ordinate (c) value (d) fraction
- A point in 4th quadrant has its ordinate:
(a) positive (b) negative (c) zero (d) one
- A point in the first quadrant is characterized by the fact that both its co-ordinates are:
(a) zero (b) positive
(c) negative (d) positive and negative oth

II- Fill in the blanks.

1. $d = \sqrt{(x_2 - x_1)^2 + (y_2 - y_1)^2}$ is called _____.
2. A point in a cartesian plane determines a _____ ordered pair of numbers.
3. With every ordered pair is associated a _____ point in the plane .
4. Points lying on the same line are called _____ points.
5. Points which do not lie on the same straight line are called _____ points.
6. Points on the axes do not lie in any _____.
7. The origin has the co-ordinates _____.
8. Points on the negative x-axis have negative abscissa and their ordinate is _____.
9. A point in the 4th quadrant has its abscissa positive and its ordinate _____.
10. A point in the first quadrant is characterized by the fact, that both its co-ordinates are _____.

SUMMARY

Distance Formula: $d = |\overline{PQ}| = \sqrt{(x_2 - x_1)^2 + (y_2 - y_1)^2}$

- 1- A point in a number plane determines a unique ordered pair of numbers.
- 2- With every ordered pair of numbers a unique point is associated in the plane.

Collinear points: Points lying on the same straight line are called collinear points.

Non-Collinear points: Points which do not lie on a same straight line are called non-collinear points.

ANSWERS

Exercise 1.1

1- 9,8 2- -11 3- 9 4- 11,71 5- 1,0 6- 18.86 7- 804.57 8- 25,1

9- $\frac{2y}{3x^2}$ 10- $\frac{25a}{14b^2}$ 11- $\frac{4a^3b^3}{5a^2+3b}$ 12- $\frac{2m}{3x^5-4m^2x^3}$ 13- $\frac{5}{c+d}$

14- $\frac{x+y}{-3}$ 15- $\frac{2x^3-x^2y+xy^2}{x^3-x^2y+xy^2-y^3}$ 16- $\frac{4x^2-2x}{x^2-1}$ 17- $\frac{3x-1}{x^3-7x-6}$

18- $\frac{2x-3y}{2x+3y}$ 19- $\frac{x-2y}{x^2-y^2}$ 20- $\frac{x-2y}{xy-y^2}$ 21- $\frac{2}{x-1}$

22- $\frac{37x+1}{x^2-12x+27}$ 23- $\frac{x^2-4x+4}{x^2+2x}$ 24- $\frac{-(x+6)}{x+1}$ 25- $\frac{x^3+x^2+20x}{x^2+4x-5}$

26- $\frac{3x+4}{2x+1}$ 27- $\frac{4x^3-x}{2x^2-1}$ 28- $\frac{x}{x^3-2x^2+2x-1}$ 29- $\frac{x}{3x-9}$

30- x 31- 1 32- $x-1$

Exercise 1.2

1- $2x^2+8y^2$ 2- $50x^2+18y^2$ 3- $24lm$ 4- l^8-m^8 5- $a^3b^3-\frac{1}{a^3b^3}-3ab+\frac{3}{ab}$

6- $4x^2+9y^2+4+12xy+12y+8x$ 7- $8p^3+12p^2q+6pq^2+q^3$

8- $9p^2+q^2+r^2+6pq+2qr+6pr$ 9- $8x^3+36x^2y+54xy^2+27y^3$

10- $(x+y-1)(x^2+y^2+2xy+x+y+1)$ 11- $(x-y+4)(x^2+y^2-2xy-4x+4y+16)$

12- $(2x+3y)(4x^2-6xy+9y^2)$ 13- $(x+3y)(x^2-3xy+9y^2)(x-3y)(x^2+3xy+9y^2)$

14- $(2a+b)(2a-b)(4a^2-2ab+b^2)(4a^2+2ab+b^2)$ 15- 4 17- $17,4$ 18- 14

19- 133 20- 118 21- 20 22- 46

ANSWERS

Exercise 1.3

- 1- (i) $\frac{\sqrt{5}}{5}$, (ii) $\frac{7\sqrt{6}}{3}$, (iii) $\frac{\sqrt{42}}{7}$ 2- (i) $3\sqrt{2}$, (ii) $35\sqrt{2}$, (iii) $4\sqrt{15} - 6\sqrt{6} - 2\sqrt{10} + 6$
(iv) $30 - 6\sqrt{5} + 5\sqrt{2} - \sqrt{10}$ (v) $5\sqrt{3} - \sqrt{15} - 10 + 2\sqrt{5}$ (vi) $35 + 7\sqrt{2} + 5\sqrt{3} + \sqrt{6}$
- 3- (i) $2 - \sqrt{3}$ (ii) $\frac{4 + \sqrt{5}}{11}$ (iii) $2\sqrt{3}(\sqrt{7} - \sqrt{5})$ (iv) $\frac{x + y - 2\sqrt{xy}}{x - y}$
(v) $\frac{105 - 10\sqrt{7}}{59}$ (vi) $5 + 2\sqrt{6}$ (vii) $\frac{29(11 - 3\sqrt{5})}{76}$ (viii) $\frac{3\sqrt{7} - 2\sqrt{3}}{3}$
- 4- (i) $2\sqrt{5}$ (ii) 18 5- (i) $2\sqrt{3}$ (ii) 14 6- (i) $-2\sqrt{2}$ (ii) 10
- 7- (i) $\frac{24 - 6\sqrt{2}}{7}$ (ii) $\left(\frac{-18 + 8\sqrt{2}}{7}\right)$ 8- (i) 40 (ii) 36
- 9- (i) $\frac{2b^2 - a^2 + 2b\sqrt{b^2 - a^2}}{a^2}$ (ii) $\frac{a - \sqrt{a^2 - 9}}{3}$

Review Exercise 1

I- Encircle the Correct Answer.

- 1- b 2- b 3- d 4- c 5- d 6- a 7- d 8- b 9- c 10- a

II- Fill in the blanks.

- 1- rational number 2- rational expression 3- $4ab$ 4- $2(a^2 + b^2)$
5- $(a+b)^3$ 6- $(a-b)^3$ 7- $a^3 - b^3$ 8- $a^3 + b^3$ 9- surd 10- 2

Exercise 2.1

- 1- $(x+y)(3a-7b)$ 2- $(a-x)(x+y)$ 3- $(a-3)(a^2+1)$
4- $(x-1)(x^2+x-1)$ 5- $(x+2y)(3a-4b)$ 6- $(a-b)(2a+c)$
7- $(a-b)(a+c)$ 8- $(4-a^3)(2-a)$ 9- $(4x-3a)^2$
10- $(1-7x)^2$ 11- $5(2x-1)^2$ 12- $2ab(a-b)^2$
13- $\left(x + \frac{1}{2}\right)^2$ 14- $\left(x - \frac{1}{x}\right)^2$ 15- $5x(x-3)^2$ 16- $(a+b)(a+b+2c)$

ANSWERS

Exercise 2.2

1- $(x+y+a)(x+y-a)$

2- $(2a+b+3c)(2a+b-3c)$

3- $(x+3a+4b)(x+3a-4b)$

4- $(y+x-c)(y-x+c)$

5- $(x+y+2xy)(x+y-2xy)$

6- $(a-2b-3ac)(a-2b+3ac)$

7- $(x-y-a+b)(x-y+a-b)$

8- $(y^2+2y+2)(y^2-2y+2)$

9- $(z^2+8y^2-4yz)(z^2+8y^2+4yz)$

10- $(x^3-6x+18)(x^3+6x+18)$

11- $(z^2-3z+4)(z^2+3z+4)$

12- $(2x-y)(x-y)(2x+y)(x+y)$

Exercise 2.3

1- $(x+4)(x+5)$

2- $(x-2)(x+7)$

3- $(x-1)(x+6)$

4- $(x-3)(x-4)$

5- $(x-13)(x+12)$

6- $(x-2)(x+1)$

7- $(x-15)(x+6)$

8- $(a-17)(a+5)$

9- $(7-x)(x+14)$

10- $(y-19)(y+8)$

11- $(x+1)(2x+1)$

12- $(x+1)(3x+2)$

13- $(x-1)(2x+1)$

14- $(2x+3)(3x-1)$

15- $(x+2)(1-2x)$

16- $(2-x)(4+5x)$

17- $(u-2)(3u-4)$

18- $(2x-3)(5x+4)$

19- $(x-6)(5x-2)$

20- $(4x-\sqrt{3})(\sqrt{3}x+2)$

Exercise 2.4

1- $(2x-y)(4x^2+2xy+y^2)$

2- $(3x+1)(9x^2-3x+1)$

3- $(1-7x)(1+7x+49x^2)$

4- $(ab+8)(a^2b^2-8ab+64)$

5- $(3-10y)(9+30y+100y^2)$

6- $(3x-4y)(9x^2+12xy+16y^2)$

7- $(xy+z)(x^2y^2-xyz+z^2)$

8- $(6p-7)(36p^2+42p+49)$

9- $(2x-\frac{1}{3})(4x^2+\frac{2}{3}x+\frac{1}{9})$

10- $(a+b)[a^2-ab+b^2+1]$

11- $(a-b)[1-(a^2+ab+b^2)]$

12- $x(1-2y)(1+2y+4y^2)$

13- $(x-y)(x+y)(x^2+y^2)(x^2+xy+y^2)(x^2-xy+y^2)(x^4-x^2y^2+y^4)$

ANSWERS

14- $(1 - \frac{4p}{q})(1 + \frac{4p}{q} + \frac{16p^2}{q^2})$

15- $(1 + 4u)(1 - 4u + 16u^2)$

16- $(2x + 3y)(4x^2 + 9y^2 - 6xy - 3)$

17- $(z + 5)(z^2 - 5z + 25)$

18- $(x + y)(x^2 - xy + y^2)(x^6 - x^3y^3 + y^6)$

19- $(m + n)(m - n)(m^2 + mn + n^2)(m^2 - mn + n^2)$

20- $x(2x - a)(2x + a)(4x^2 + 2ax + a^2)(4x^2 - 2ax + a^2)$

21- $(x - 3a)(x^2 + 3ax + 9a^2)$

22- $(x + 3a)(x^2 - 3ax + 9a^2)$

Exercise 2.5

1- 3 2- -6 3- -47 4- 0 5- -84 6- yes 7- yes 8- no 9- no

10- yes 11- no 12- yes 13- yes 14- no 15- no 16- yes 17- yes

18- no 19- $k = 1$ 20- $k = 1$

Review Exercise 2

I- Encircle the Correct Answer.

1- b 2- c 3- d 4- a 5- c 6- b 7- a 8- a 9- a 10- a

II- Fill in the blanks.

1- one 2- two 3- three 4- $(x - 3)(x + 3)$ 5- $(x + 1)(x + 3)$ 6- $(x + 2)(x^2 - 2x + 4)$ 7- $(x - 2)(x^2 + 2x + 4)$ 8- 3 9- 11 10- 0

Exercise 3.1

1- ab

2- $3qr$

3- $4xy^2z^2$

4- $7ab$

5- $3x^2y^2$

6- $2abc$

7- $x + 4$

8- $x^2 - y^2$

9- $t + 3$

10- $x - 2$

11- $1 + x$

12- $x - 2$

13- $x + 1$

14- $x(x + 3)$

15- $5abc$

ANSWERS

Exercise 3.2

- 1- $x^2 - x + 1$ 2- $2x^2 + 3x - 2$ 3- $2(x-1)$ 4- $9x(x+3)$ 5- $(x-1)^2(x+1)$ 6- $(x-2)$
7- $(x-1)$ 8- $(3x-5)$ 9- $2x+1$ 10- $(x+3)$

Exercise 3.3

- 1- $420a^4x^4y^4$ 2- $15a^4b^3c^5$ 3- $12abc$ 4- $x^2y^2z^2$
5- $p^2q^2(p-q)(p+q)(p^2+pq+q^2)$ 6- $(x+4)(x-4)(x^2-4x+16)$
7- $(x-2)(x+3)(x+1)(x-1)$ 8- $(y+3)(y-2)(y+3)(y-3)$
9- $(1+y)(1-y)(1-2y)(y^2-y+1)$ 10- $(x-y)(x+y)(x^2+y^2)(x^4+x^2y^2+y^4)$
11- $(x+1)(x^2-x+1)(x^2+x+1)^2$
12- $(x+y)(x^2+y^2)(x-y)(x^2-xy+y^2)(x^4-x^2y^2+y^4)$ 13- $(2x+3)(x+1)^2(x+3)$
14- $x^2(x+3)(x-2)(x-3)$ 15- $(x+y)^2(x+2y)^2$

Exercise 3.4

- 1- x^2+1 ; x^4-1 2- $(x^2-4)(x-3)(x^3-x^2-4x+4)$ 3- $2x^2+1$; $2x^4-x^2-1$
4- $2x^2+3x-2$; $(3x-1)(8x^4+6x^3-15x^2+9x-2)$
5- $(3x^2+8x-3)$; $(2x^2-3x+1)(3x^4+17x^3+27x^2+7x-6)$
6- (x^2+2x-3) ; $(2x^2-x-5)(2x^4+x^3-20x^2-7x+24)$
7- (x^3-1) ; $(x-1)(x^4+x^3-x-1)$
9- $x^2-12x+35$ 10- $(6x^2+x-2)$ 11- $x+4$ 12- $(x+1)$; $(x^3+1)(x^4+x^3-x-1)$
14- $x^3-7x^2+16x-12$ 15- $x^4+8x^3+11x^2-32x-60$ 16- x^5-x^4-4x+4

Exercise 3.5

- 1- $\frac{2(2a+1)}{a(a+1)(a+2)}$ 2- $\frac{2ax+x-3a-6a^2}{(x-2a)(x-3a)}$ 3- $2+a^4$ 4- $\frac{1}{x^4+x^2+1}$

ANSWERS

5- $\frac{2b^2(a-c)}{(a+b)(b+c)}$ 6- $\frac{6x^3}{x^6-1}$ 7- $\frac{2a^3}{a^2-b^2}$ 8- 1 9- 1 10- 1

11- $\frac{a}{a-b}$ 12- $\frac{a+1}{a+2}$

Exercise 3.6

1- $\pm(4x+3y)$ 2- $\pm(x-3)(x-4)(x-5)$ 3- $\pm(x+1)(x+7)(2x-3)$ 4- $\pm(x^2+6x+4)$

5- $\pm(4x^2+16x+11)$ 6- $\pm(x+\frac{1}{x}-5)$ 7- $\pm(t+\frac{1}{t}-2)$ 8- $\pm(x^2+\frac{1}{x^2}-2)$

9- $\pm(2x^2+3x+4)$ 10- $\pm(\frac{3x}{2y}-\frac{1}{2}-\frac{2y}{3x})$ 11- $x=8$ 12- $l=4, m=10$

Review Exercise 3

I- Encircle the Correct Answer.

1- a 2- c 3- c 4- a 5- b 6- a 7- c 8- c 9- a 10- a

II- Fill in the blanks.

1- two 2- two 3- H.C.F 4- L.C.M 5- H.C.F 6- second expression

7- $2x+1$ 8- $x+2$ 9- $2x^2y^3$ 10- $6x^2y^2z$

Exercise 4.1

1- (i) 8, (ii) 80, (iii) 11, (iv) 2 2- $\frac{5}{2}$ 3- 2 4- -7 5- -2

6- 3 7- 4 8- 4 9- 3 10- {4} 11- {9} 12- {18} 13- {8}

14- {} 15- {} 16- {13, 5} 17- {8} 18- {13} 19- {101} 20- {15}

Exercise 4.2

1- ± 9 2- -1, 7 3- -6, 4 4- -1, 4 5- $\frac{5}{3}, \frac{-13}{3}$ 6- $x < 7$

ANSWERS

- 7- $x > -3$ 8- $x < -1$ 9- $x < -10$ 10- $x > -\frac{17}{9}$ 11- $x < -21$
12- $x > -12\frac{5}{7}$ 13- $x \geq 6$ 14- $x \leq 1\frac{7}{18}$ 15- $x \geq 1\frac{1}{2}$ 16- $x \geq 0$

Review Exercise 4

I- Encircle the Correct Answer.

- 1- a 2- c 3- c 4- c 5- c 6- a 7- c 8- a

II- Fill in the Blanks.

- 1- > 2- > 3- < 4- < 5- > 6- > 7- > 8- <
9- < 10- < 11- < 12- >

Exercise 5.1

- 1- -2,6 2- 1,5 3- -8,1 4- 2,3 5- $2\frac{4}{3}$ 6- $-8\frac{1}{2}$ 7- 3,-4
8- $3, -\frac{1}{3}$ 9- $2, -\frac{1}{2}$ 10- $2, \frac{-4}{5}$ 11- $2, \frac{-3}{2}$ 12- $\frac{-1}{2}, \frac{4}{5}$ 13- $1, \frac{-1}{2}$
14- $5 \pm 2\sqrt{7}$ 15- $3 \pm 2\sqrt{3}$ 16- $\frac{-1 \pm \sqrt{5}}{2}$ 17- $-3 \pm 2\sqrt{3}$ 18- $\frac{2 \pm \sqrt{2}}{2}$
19- $\frac{3 \pm \sqrt{3}}{2}$ 20- $\frac{-5 \pm \sqrt{73}}{6}$ 21- $\frac{-m \pm \sqrt{m^2 - 4n}}{2}$ 22- $\frac{3 \pm 4\sqrt{15}}{11}$ 23- $-2 \pm \sqrt{17}$
24- $\frac{10 \pm 4\sqrt{15}}{5}$ 25- $\{13, -2\}$

Exercise 5.2

- 1- 2,3 2- $\frac{3}{4}, \frac{1}{2}$ 3- $-1, \frac{2}{3}$ 4- $-1, \frac{3}{2}$ 5- -5,3 6- $3, \frac{-7}{2}$ 7- $\pm\sqrt{10}$
8- $\pm 2\sqrt{6}$ 9- ± 8 10- $\frac{5}{3}$ 11- 0,-5 12- $5, \frac{1}{3}$

ANSWERS

Exercise 5.3

- 1- 5,7 2- 8,10 3- 9,18 4- 5 5- 5,6 6- 12,13 7- 7,9
8- 4,8 or 8,4

Review Exercise 5

I- Encircle the Correct Answer.

- 1- a 2- b 3- b 4- a 5- c 6- c 7- c 8- c 9- b 10- b

II- Fill in the blanks.

- 1- quadratic 2- quadratic formula 3- $x(2x-3)$ 4- $\{-1,3\}$ 5- three
6- quadratic formula 7- $\{2,3\}$ 8- $\{\pm 3\}$ 9- $(x-2)(x+2)(x^2+4)$ 10- $\{\pm 1\}$

Exercise 6.1

- 1- $2-by-2, 3-by-1, 3-by-2$ 2- $2-by-2, 3-by-3, 1-by-3$
3- 5 4- $B=F, G=J, H=K, C=E, A=D$

Exercise 6.2

- 1- Row matrix = A, Column matrix = C, Square matrices = B, D, E, F Rectangular matrices = A, C, G
2- Diagonal matrix are A, B, C, D, E, F, G Scalar matrix are B, D, E, G, Identity is D

3- $\begin{bmatrix} 3 & -1 \\ 4 & 4 \end{bmatrix}, \begin{bmatrix} -3 & -1 \\ -2 & 4 \end{bmatrix}, \begin{bmatrix} a & c \\ -b & d \end{bmatrix}, \begin{bmatrix} l & p & a \\ m & q & b \\ n & r & c \end{bmatrix}$ 4- A, C 5- A, C, E 6- C 7- A

Exercise 6.3

1- (i) $\begin{bmatrix} 2 & 4 & 9 \\ 3 & 8 & 11 \\ 5 & 13 & 1 \end{bmatrix}$ (ii) $\begin{bmatrix} 2 & 2 & -1 \\ -1 & 2 & -1 \\ 3 & 5 & 5 \end{bmatrix}$ (iii) $\begin{bmatrix} -2 & -2 & 1 \\ 1 & -2 & 1 \\ -3 & -5 & -5 \end{bmatrix}$ (iv) $\begin{bmatrix} 4 & 9 & 23 \\ 8 & 19 & 28 \\ 11 & 30 & 0 \end{bmatrix}$

(v) $\begin{bmatrix} 6 & 5 & -8 \\ -5 & 3 & -9 \\ 8 & 11 & 17 \end{bmatrix}$ (vi) $\begin{bmatrix} 2 & 1 & -6 \\ -3 & -1 & -7 \\ 2 & 1 & 7 \end{bmatrix}$ 2- $-A = \begin{bmatrix} -4 & -3 \\ -2 & -6 \end{bmatrix}, -B = \begin{bmatrix} -\sqrt{2} & -3 \\ -4 & -\sqrt{3} \end{bmatrix}$

ANSWERS

$$-C = \begin{bmatrix} -1 \\ 7 \\ -4 \end{bmatrix}, -D = \begin{bmatrix} -1 & 0 & 2 \\ 0 & -3 & -4 \\ -2 & 1 & 3 \end{bmatrix}, -E = [-2 \ -5 \ 3] \quad 4. -1, 2 \quad 6. X = \begin{bmatrix} 2 & 1 \\ -4 & 2 \\ -3 & 2 \end{bmatrix}$$

7. $a=2, b=-4, c=4, d=3, e=4, f=2$ 8. $w=-1, x=1, y=7, z=-8$

9. $\begin{bmatrix} -a & -b \\ -c & -d \end{bmatrix}$

Exercise 6.4

9. $[12 \ 13]$

10. $\begin{bmatrix} 5 \\ -3 \end{bmatrix}$

11. $\begin{bmatrix} 2 & 4 \\ 1 & -5 \end{bmatrix}$

12. $\begin{bmatrix} 1 & -9 \\ -3 & 17 \end{bmatrix}$

13. $\begin{bmatrix} 10 & 1 \\ -2 & 10 \end{bmatrix}$

14. $\begin{bmatrix} 10 & -14 \\ 15 & 3 \end{bmatrix}$

15. $a = \frac{10}{7}, b = 0$

Exercise 6.5

1. (i) $uy - vx$ (ii) -13 (iii) 0 (iv) $\frac{13}{64}$

2. (i) *singular* (ii) *non-singular* (iii) *non-singular*

3. (i) $\begin{bmatrix} 3 & -2 \\ -1 & 1 \end{bmatrix}$ (ii) $\begin{bmatrix} 3 & -1 \\ -5 & 2 \end{bmatrix}$ (iii) $\begin{bmatrix} \frac{1}{2} & 0 \\ \frac{1}{6} & \frac{1}{3} \end{bmatrix}$ (iv) *Inverse does not exist*

(v) $\begin{bmatrix} 4 & \frac{-3}{2} \\ -1 & \frac{1}{2} \end{bmatrix}$ (vi) $\begin{bmatrix} -1 & 0 \\ 0 & -1 \end{bmatrix}$ (vii) $\begin{bmatrix} \frac{3}{5} & \frac{4}{5} \\ -\frac{4}{5} & \frac{3}{5} \end{bmatrix}$ 4. $M^{-1} = \begin{bmatrix} -2 & 1 \\ \frac{3}{2} & \frac{-1}{2} \end{bmatrix}$

Exercise 6.6

1. $\frac{-9}{2}$ 2. (i) $(3, 1)$ (ii) $\left(\frac{7}{3}, \frac{3}{2}\right)$ (iii) $\left(\frac{-1}{2}, \frac{2}{5}\right)$ (iv) $(-1, 5)$ (v) $(0, 2)$ (vi) $(-2, 6)$

3. $(3, -1)$ 4. (i) $(-1, 2)$ (ii) $(1, -1)$ (iii) $(4, -1)$ (iv) *No Solution* (v) $(2, -1)$
 (vi) $\left(\frac{31}{21}, \frac{59}{21}\right)$

5. (i) $2x - y = 2, 5x + 2y = 4$ (ii) $-5x + 2y = 2, 2x - 3y = -1$
 (iii) $-4x + y = 1, 5x + 4y = -1$ (iv) $0.8x - 0.6y = 1, 0.6x + 0.8y = 2$

ANSWERS

Review Exercise 6

I- Encircle the Correct Answer.

- 1- a 2- a 3- a 4- c 5- a 6- c 7- b 8- c 9- c 10- c

II- Fill in the blanks.

- 1- order 2- row matrix 3- same order 4- same 5- equal 6- 1
7- associative 8- skew symmetric 9- $B^t A^t$ 10- $B^{-1} A^{-1}$

Exercise 7.1

- 1- (i) 130° (ii) 115° (iii) 42° (iv) 30° (v) 108° (vi) 20° 2- $105^\circ, 75^\circ$ 3- 70°
4- $-0^\circ, 100^\circ$ 5- $70^\circ, 30^\circ$ 6- $x + 90^\circ + 30^\circ = 180^\circ \Rightarrow x = 60^\circ$ 7- (i) $a = 40^\circ$
(ii) $c = 35^\circ, d = 145^\circ$ (iii) $e = 29^\circ, f = 151^\circ$ (iv) $b = 135^\circ$
(v) $q = 77^\circ, P = 103^\circ, r = 103^\circ$ (vi) $j = 30^\circ, k = 150^\circ, l = 30^\circ$
(vii) $g = 140^\circ, h = 40^\circ, i = 140^\circ$ (viii) $k = 145^\circ$
(ix) $P = 58^\circ, M = 122^\circ, N = 122^\circ$ (x) $a = 158^\circ, b = 112^\circ$

Exercise 7.2

- 1- (a) $(\angle 1, \angle 2), (\angle 3, \angle 4)$ (b) $(\angle 1, \angle 6), (\angle 3, \angle 8), (\angle 2, \angle 7), (\angle 5, \angle 4)$ (c) none
(d) $(\angle 1, \angle 8), (\angle 1, \angle 4), (\angle 4, \angle 7), (\angle 7, \angle 8), (\angle 5, \angle 6), (\angle 5, \angle 2), (\angle 2, \angle 3), (\angle 3, \angle 6)$
(e) $(\angle 1, \angle 7), (\angle 4, \angle 8), (\angle 5, \angle 3), (\angle 2, \angle 6)$
2- (a) $(\angle 1, \angle n), (\angle m, \angle r)$ (b) $(\angle p, \angle n), (\angle m, \angle s), (\angle q, \angle r), (\angle 1, \angle 1)$ (c) none
(d) $(\angle p, \angle m), (\angle n, \angle s), (\angle q, \angle 1), (\angle r, \angle 1), (\angle q, \angle p), (\angle 1, \angle m), (\angle r, \angle n), (\angle 1, \angle s)$
(e) $(\angle p, \angle 1), (\angle m, \angle q), (\angle n, \angle 1), (\angle s, \angle r)$

Exercise 7.3

- 1- yes, no, yes 2- yes 3- yes 4- 10cm, 12cm, 14cm, 16cm, 18cm
5- 6cm, 12cm, 18cm, 21cm 6- 15cm, 21cm, 9cm, 12cm, 1:3
7- $\overline{AB} \cong \overline{DE}, \overline{AC} \cong \overline{DF}, \overline{BC} \cong \overline{EF}$ $\angle A \cong \angle D, \angle B \cong \angle E, \angle C \cong \angle F$
8- No: size may be different 9- yes: size and shape are same

Exercise 7.4

- 1- (a) (i) $\overline{AB} \cong \overline{FD}$ (ii) $\overline{BC} \cong \overline{DE}$ (iii) $\overline{AC} \cong \overline{FE}$ (iv) $\angle A \cong \angle F$ (v) $\angle B \cong \angle D$ (vi) $\angle C \cong \angle E$
(b) $\angle R$ (c) \overline{EF} (d) $S.A.S \cong S.A.S$ (e) $ASA \cong ASA$
2- (i) $\triangle ABC \cong \triangle DFE$ by $S.S.S \cong S.S.S$ (ii) $\triangle XYZ \cong \triangle DFE$ by $S.S.A \cong S.S.A$
(iii) $\triangle ABC \cong \triangle CDA$, by $A.S.A \cong A.S.A$ (iv) $\triangle PQT \cong \triangle SRT$ by $S.A.S \cong S.A.S$

ANSWERS

- 3- $\overline{AD} \cong \overline{DA}$, $\overline{DB} \cong \overline{AC}$, $\overline{AB} \cong \overline{DC}$, $\angle BAD \cong \angle CDA$, $\angle ADB \cong \angle DAC$, $\angle ABD \cong \angle DCA$,
Condition used $S.S.S \cong S.S.S$, $m\angle ADB = 40^\circ$
- 4- (i) Similar Triangles (ii) Similar Parallelogram (iii) Similar Triangles
- 5- $\overline{MN} \leftrightarrow \overline{PQ}$, $\overline{NO} \leftrightarrow \overline{QR}$, $\overline{PR} \leftrightarrow \overline{MO}$, $\angle 1 \leftrightarrow \angle 4$

Exercise 7.5

- (i) rectangle (ii) square (iii) quadrilateral (iv) bisect (v) congruent

Exercise 7.6

- (i) circle (ii) radius (iii) chord (iv) diameter (v) semicircle
(vi) major arc (vii) radius (viii) sector (ix) secant line (x) right angle

Review Exercise 7

I- Encircle the Correct Answer.

- 1- b 2- c 3- b 4- b 5- a 6- c 7- a 8- b 9- c 10- c

II- Fill in the blanks.

- 1- adjacent 2- supplementary 3- obtuse 4- vertical 5- 180° 6- each other
7- congruent 8- scalene 9- diameter 10- right

Review Exercise 8

I- Encircle the Correct Answer.

- 1- c 2- c 3- c 4- c 5- a 6- a 7- a 8- c 9- c 10- a

II- Fill in the blanks.

- 1- concurrent 2- concurrent 3- concurrent 4- concurrent 5- altitude
6- median 7- angle bisector 8- three 9- three 10- three

Exercise 9.1

- 1- (i) 5 (ii) 12 (iii) $4\sqrt{231}$ 3- $\sqrt{2}l$ 4- $8\sqrt{2}$
5- (i) right triangle (ii) not right Δ (iii) right Δ 6- 15cm 7- 7cm 8- 8m 9- 5

ANSWERS

Exercise 9.2

- 1- 20 stones 2- 24000 stones 3- Rs. 223 4- 645.50m 5- 1mm 54sec
6- 98 cm^2 7- (i) 8967 cm^2 (ii) 16.8 m^2 8- 9000 m^2 9- $16\sqrt{110}\text{ m}^2$
10- (i) 44 cm^2 (ii) 0.5 (iii) 401.14 mm^2 11- 154 m^2 12- $16\sqrt{3}\text{ m}^2$ 13- $9\sqrt{3}\text{ cm}^2$
14- 210 cm^2 15- 7cm, 21cm 16- 1666.67cm 17- 72cm 18- 3600 cm^2 19- 4cm

Exercise 9.3

- 1- 64 cm^3 2- 64 cm^3 3- 24 m^3 4- 502.86 cm^3 5- 94.3 cm^3 6- 113.1 cm^3
7- 127.3 cm^3 8- 339.4 cm^3

Review Exercise 9

I- Encircle the Correct Answer.

- 1- a 2- c 3- c 4- a 5- d 6- c 7- a 8- c 9- c

II- Fill in the blanks.

- 1- Pythagoras 2- Area 3- $\frac{1}{2} \times \text{base} \times \text{altitude}$ 4- $\sqrt{S(s-a)(s-b)(s-c)}$
5- $\frac{\sqrt{3}a^2}{4}$ 6- $l \times b$ 7- πr^2 8- l^3 9- $l \times b \times h$ 10- $\frac{1}{3}\pi r^2 h$

Exercise 10.1

- 1- (i) lies on \overrightarrow{OX} (ii) lies on \overrightarrow{OY} (iii) lies in QII (iv) In Q I
(v) on \overrightarrow{OX} (vi) in QIII (vii) in QIV (viii) In QII
(ix) on \overrightarrow{OY} (x) in QIV

- 2- (i) $2\sqrt{10}$ (ii) $\sqrt{17}$ (iii) $\sqrt{106}$ (iv) $(a-b)\sqrt{2}$ 3- $x+y-10=0$
5- (10,0)

Review Exercise 10

I- Encircle the Correct Answer.

- 1- a 2- c 3- a 4- b 5- a 6- c 7- c 8- a 9- b 10- b

II- Fill in the blanks.

- 1- Distance formula 2- unique 3- unique 4- collinear 5- non-collinear
6- quadrant 7- (0,0) 8- zero 9- negative 10- positive

GLOSSARY

Unit-1 ALGEBRAIC FORMULAS AND APPLICATIONS

Formula: Where we have a rule to calculate some quality, we write the rule as a formula.

$$(a \pm b)^2 = a^2 \pm 2ab + b^2$$

$$(a+b)^2 + (a-b)^2 = 2(a^2 + b^2)$$

$$(a+b)^2 - (a-b)^2 = 4ab$$

$$(a+b+c)^2 = (a^2 + b^2 + c^2 + 2ab + 2bc + 2ac)$$

$$(a \pm b)^3 = a^3 \pm 3ab(a \pm b) \pm b^3$$

$$(x+y)(x-y)(x^2 - xy + y^2)(x^2 - xy + y^2)$$

Surd: A surd is an irrational number that contains an irrational square root.

Pure Surd: A surd which has unity only as rational factor, the other factor being irrational is called a pure surd.

Mixed surd: A surd which has rational factor other than unity, the other factor being irrational is called mixed surd.

Similar surd: Surds having the same irrational factor are called similar or like surd.

Unlike surd: Surd having no common irrational factor are know as unlike surd.

Rationalizing Factor: When the product of two surd is rational, then each one of them is called the rationalizing factor of the other.

Unit-2 FACTORIZATION

Linear Polynomial: A polynomial of degree "1" is called a linear polynomial.

Quadratic Polynomial: A polynomial of degree "2" is called a quadratic polynomial.

Cubic Polynomial: A polynomial of degree "3" is called a cubic polynomial.

Types of Factorization: $kx + ky + kz$, $ax + ay + bx + by$, $a^2 \pm 2ab + b^2$

$$a^2 - b^2, (a^2 \pm 2ab + b^2) - c^2, a^4 + a^2b^2 + b^4 \text{ or } a^4 + b^4,$$

$$x^2 + px + q, x^2 + bx + c,$$

$$a^3 + 3a^2bx + 3ab^2 + b^3, a^3 - 3a^2b + 3ab^2 - b^3,$$

$$a^3 \pm b^3.$$

Remainder Theorem: If a polynomial $P(x)$ of degree $n \geq 1$ is divided by a polynomial 'x-a' where 'a' is any constant, then remainder is $P(a)$.

Remainder Theorem: If a polynomial $P(x)$ is divided by 'x-a' such that $P(a) = 0$, then 'x-a' is a factor of $P(x)$.

Unit-3 ALGEBRAIC MANIPULATION

H.C.F: The H.C.F of two or more their two algebraic expressions is the expression of highest degree which divides each of them without remainder.

L.C.M: The least common multiple of two or more algebraic expressions is the expression of lowest degree which is divisible by each of them without remainder.

Unit-4 LINEAR EQUATIONS AND INEQUALITIES

Linear Equation: An equation that can be written in the form $ax + b = 0$, $a \neq 0$ where a and b are constants and x is a variable is called a linear equation in one variable.

Solution of a Linear equation : Any value of the variable, which makes the equation a true statement is called the solution of a linear equation.

Absolute Value: For each real number 'x' the absolute value of x , denoted by $|x|$, is defined by:

$$|x| = \begin{cases} x, & \text{if } x > 0 \\ 0, & \text{if } x = 0 \\ -x, & \text{if } x < 0 \end{cases}$$

Linear Inequalities: Two algebraic expressions joined by an inequality symbol such as $>$, $<$, \leq , \geq is called an inequality.

Trichotomy Property: If $x, y \in R$, then either $x > y$ or $x = y$ or $x < y$.

Transitive Property: If $x, y, z \in R$, then $x > y$ and $y > z \Rightarrow x > z$.

Additive Property: If $\forall a, b, c, d \in R$, then $a > b$ and $c > d \Rightarrow a + b > b + d$ and $c < d$ and $c < d \Rightarrow a + c < b + d$.

Multiplicative Property: $\forall a, b, c, d \in R$, $a > b$ and $c > d \Rightarrow ac > bd$ and $a < d$ and $c > d \Rightarrow ac > bd$.

Unit-5 QUADRATIC EQUATIONS

Quadratic Equation: A quadratic equation in one variable is an equation that can be written in the form $ax^2 + bx + c = 0$, where $a \neq 0$. Here 'x' is a variable, where a, b and c are real numbers.

Solution of quadratic Equation: We can solve a quadratic equation by
(i) factorization (ii) completing the square method.

Quadratic Formula: $x = \frac{-b \pm \sqrt{b^2 - 4ac}}{2a}$

Unit-6 MATRICES AND DETERMINANTS

Matrix: A rectangular array of number, enclosed by a pair of brackets and subject to certain rule is called a matrix.

Order of a matrix: The number of rows and columns in a matrix determine its order.

Row matrix: A matrix consisting of one row only is called a row matrix.

Column matrix: A matrix consisting of one column only is called a column matrix.

Square matrix: In a square matrix, the number of rows and columns are equal.

Rectangular matrix: In a rectangular matrix, number of rows and columns are not same.

Zero or null matrix: If all elements in a matrix are zero, the matrix is called a zero or null matrix.

Unit or Identity matrix: In an identity matrix, the diagonal elements are unity and off diagonal elements are all zero.

Transpose of a matrix: A matrix obtained by interchanging rows into columns is called transpose of a matrix.

Symmetric matrix: A matrix A is said to be symmetric, if $A' = A$.

Skew-Symmetric matrix : A matrix A is said to be skew-symmetric, if $A' = -A$.

Determinant: A real number associated with a square matrix is called determinant of a square matrix.

Singular matrix: If the determinant of a square matrix is zero, it is called a singular matrix, other wise non-singular matrix. Adjoint of a square matrix of order 2×2
In the adjoint of a square matrix of order 2×2 , the diagonal elements are interchanged, where as the sign of foo diagonal elements are changed.
Multiplicative inverse of a square matrix, A matrix B is said to be multiplications inverse of ' A ', is $AB = I$.

Unit-7 FUNDAMENTALS OF GEOMETRY

Angle: An angle is the union of two rays with common end point.

Right Angle: A right angle contains 90° .

Straight Angle: A straight angle contains 180° .

Acute Angle: An acute angle contains more than 0° and less than 90° .

Obtuse Angle: An obtuse angle contains more than 90° and less than 180° .

Reflex Angle: An reflex angle contains more than 180° and less than 360° .

Equal Angle: Equal angle are angle with equal measures.

Adjacent Angle: Two angles with the common vertex and a common side between them.

Complementary Angle: Two angles whose sum is a right angle.

Supplementary Angle: Two angles whose sum is a straight angle.

Vertical Angle: Two non adjacent angles, each less than a straight angle, formed by two intersecting lines.

Result 1: The sum of the angles of a triangle is a straight angle.

2: If two angles are complements of equal angles, they are equal.

3: If two angles are supplements of the same angle, they are equal.

4: Two lines parallel to a third line are parallel to each other.

5: If three parallel lines in percept congruent segments of one transversal, they intersect congruent segment of every transversal.

6: If a line bisect one side of a triangle and parallel to a second side. It bisect the third side.

Transversal: A transversal is a line that intersects two lines in different points.

Congruent Figures: Two geometrical figures which have the same size and shape are congruent.

Polygon: A polygon is a closed broken line in a plane.

Equilateral Triangle: A triangle with three equal sides.

Isosceles Triangle: A triangle with two equal sides.

Scalene Triangle: A triangle with no equal side.

Right Triangle: A triangle containing one right angle.

Obtuse Triangle: A triangle containing one obtuse angle.

Acute Triangle: A triangle containing three acute angle.

Equiangular Triangle: A triangle containing three equal angle.

Properties for congruency between two Triangle: (i) $SSS \cong SSS$ (ii) $SAS \cong SAS$
(iii) $ASA \cong ASA$ (iv) $AAS \cong AAS$ (v) $RHS \cong RHS$

Quadrilateral: A polygon with four sides.

Parallelogram: A quadrilateral with two pairs of parallel sides.

Rectangle: A parallelogram containing a right angle.

Square: A equilateral rectangle.

Circle: A set of points in a plane which are at a constant distance from a fixed point.

Radius: A segment joining the center to any point on the circle.

Diameter: A chord that passes through the center.

Arc: A portion of a circle consisting of two end points and the set of points on the circle between them.

Semi Circle: An arc which is half of a circle.

Minor Arc: An arc less than a semi-circle.

Major Arc: An arc greater than a semi-circle.

Equal Circles: Circles having equal radii and equal diameters.

Secant Line: A line which intersects a circle in two points.

Tangent: A line perpendicular to the radius of a circle at its outer extremity.

Sector: A circular region bounded by an arc of a circle and its two corresponding radial segments.

Concyclic Points: Points lying on the circumference of the same circle.

Concentric Circles: Circles in the same plane with same center and different radii.

Central Angle: An angle formed at the center of the circle by two radii.

Result: (1) Angle in a semi-circle is a right angle.

(2) Angle in the segment are equal.

(3) All angles inscribed in the same arc are equal in measure.

Unit-8 PRACTICAL GEOMETRY

- 1- An angle bisector of a triangle is a line-segment that bisects an angle of the triangle and has its other end on the side opposite to that angle.
- 2- Every triangle has three angle bisectors, one for each angle.
- 3- An altitude of a triangle is the line-segment from one vertex, perpendicular to the line containing the opposite side.
- 4- Every triangle has three altitudes, one from each vertex.
- 5- A line-segment which bisects any side of a triangle and makes a right angle with the side as its midpoint is called the perpendicular bisector of the side of a triangle.
- 6- Every triangle has three perpendicular bisectors, one for each side.
- 7- The point at which the three angle bisectors of a triangle meet is called the incentre of the triangle.
- 8- The point at which the three altitudes of a triangle meet is called the orthocentre of the triangle.
- 9- The point of intersection of the three perpendicular bisectors of the sides of a triangle is called the circumcentre of the triangle.
- 10- The point at which the three medians of a triangle meet is called the centroid of a triangle.
- 11- A line coplanar with a circle intersecting the circle at one point only is called the tangent line to the circle.

Unit-9 AREAS AND VOLUMES

Pythagoras Theorem: The square of the hypotenuse of a right triangle is equal to the sum of the squares of the legs.

Area: The space inside the boundary of a shape.

Area of a Triangle: $A = \frac{1}{2} \times \text{base} \times \text{altitude}$.

Area of a Triangle: $A = \sqrt{S(s-a)(s-b)(s-c)}$ $S = \frac{a+b+c}{2}$, a, b, c are the sides of a triangle.

Area of an Equilateral Triangle: $A = \frac{\sqrt{3}a^2}{4}$, where 'a' is the side of the triangle.

Area of a Rectangle: $A = \text{length} \times \text{breadth}$.

Area of a Square: $A = \text{side} \times \text{side}$.

Area of a Parallelogram: $A = \text{base} \times \text{altitude}$.

Area of a Circle: $A = \pi r^2$.

Circumference of a Circle: $C = 2\pi r$.

Area of a Semi-Circle: $A = \frac{1}{2}(\pi r^2)$

Area of a Concentric Circle: $A = [r_1^2 - r_2^2]$

r_1 is the radius of outer circle.

r_2 is the radius of inner circle.

Volume: The space/inside/the/boundary/of/a/three/dimensional/shape.

Volume of a Cube: $V = l^3$, l is the length of edge.

Volume of a Cuboid: $V = l \times b \times h$ $l = \text{length}$ $b = \text{breadth}$ $h = \text{height}$

Volume of a Right Circular Cylinder: $V = \pi r^2 h$

$h = \text{height of the cylinder}$

$r = \text{radius of the base}$

Volume of a Right Circular Cone: $V = \frac{1}{3} \pi r^2 h$

$h = \text{height of the cone}$

$r = \text{radius of the base}$

Volume of Sphere: $V = \frac{4}{3} \pi r^3$

Volume of a Hemisphere: $V = \frac{2}{3} \pi r^3$

Unit-10 INTRODUCTION OF COORDINATE GEOMETRY

Distance Formula: $d = |PQ| = \sqrt{(x_2 - x_1)^2 + (y_2 - y_1)^2}$

- 1- A point in a number plane determines a unique ordered pair of numbers.
- 2- With every ordered pair of numbers is associated a unique point in the plane.

Collinear Points: Points lying on the same straight line are called collinear points.

Non-Collinear Points: Points which do not lie on a same straight line are called non-collinear points.

SYMBOLS

Symbol	Stands for	Symbol	Stands for
<	is/less/than	\because	because//as
>	is/greater/than	\therefore	therefore///so
\leq	is/less/than/or/equal/to	$:$	ratio
\geq	is/greater/than/or/equal/to	\therefore	is/proportional/to
=	is/equal/to	∞	varies
\neq	is/not/equal/to		tally/mark
\nless	is/not/less/than	Σ	summation
\ngtr	is/not/greater/than	\overline{AB}	line/segment AB
\in	belongs/to	\overrightarrow{AB}	ray AB
\forall	for/all	\overleftrightarrow{AB}	line
$\sqrt{\quad}$	square/root	\angle	angle
$ x $	absolute/value/of x	\triangle	triangle
\Rightarrow	implies/that	\sim	is/similar/to
\Leftrightarrow	if/and/only/if	\cong	is/congruent/to
\wedge	and	\approx	is/approximately/equal/to
\cup	union	\parallel	is/parallel/to
\vee	or	\widehat{AB}	arc AB
\subset	infer/section	\leftrightarrow	correspondence

A

Area Of Concentric Circles	261
Absolute Value	97
Acute Angle	177
Add And Subtract Matrices	138
Addition And Subtraction Of Matrices	138
Addition And Subtraction Of Surds	23
Addition Of Matrices	138
Additive Identity Of Matrices	142
Additive Inverse Of A Matrix	143
Adjacent Angles	178
Adjacent, complementary and supplementary angles	178
Adjoint Of A Matrix	157
Algebraic Expressions	2
Algebraic Manipulation	57
Altitudes Of A Triangle	225
Angle	176
Angle Bisectors Of A Triangle	224
Angle In A Semi-circle Is A Right Angle	210
Angle In The Same Segment Are Equal	211
Applications	213
ARC	208
Area Of A Circle	260
Area Of A Parallelogram When Base And Altitude Are Given	255
Area Of A Semicircle	260
Area Of A Triangle When All The Three Sides Are Given	252
Area Of An Equilateral Triangle When Its Side Is Given	254
Area Of Four Walls Of A Room	256
Areas	251
Areas And Volumes	247
Areas Of Rectangular And Square Fields	257
Associative Law	141
Associative Law Of Matrices With Respect To Multiplication	147

B

Basic Operations On The Algebraic Fractions	71
---	----

C

Calculate Unknown Angles	182
Calculate Unknown Angles Of A Triangle	184

Center	206
Central Angle	212
Chord	207
Circle	206
Collinear And Non-collinear Points	281
Collinear Points	281
Collinearity Of Three Points	282
Column Matrix	133
Commutative Law	141
Complementary Angles	179
Concentric Circles	209
Congruent And Similar Figures	193
Congruent Figures	193
Congruent Triangles	198
Conjugate Binomial Surds	27
Construction	222
Construction Of Quadrilaterals	230
Construction Of Triangle	222
Cramer's Rule	167
Cube	264
Cube And Cuboid	264
Cubic Polynomials	36
Cuboid	265

D

Derivation Of Quadratic Formula	115
Determinant Function	156
Diagonal Matrix	134
Diagonals Of A Rectangle Bisect Each Other	204
Diagonals Of A Square Bisect Each Other	203
Diameter	207
Direct Common Tangent Or External Tangent	235
Distance Between Two Points	278
Distance Formula	276
Distributive Laws	149
Division Of A Rational Expression	9
Drawing Tangents	239
Drawing Tangents To Two Equal Circles	235
Drawing Tangents To Two Un-equal Circles	237

E

Equal Angles	178
Equal Circles	208
Equations Involving Absolute Value	97
Equations Involving Radicals	93
Evaluate Determinant Of A Matrix	156
Examine A Given Algebraic Expression	4

INDEX

F			
Factorization	35	Minor Arc	208
Factorization Of Expressions	36	Mixed Surds	22
Factorizing A Cubic Polynomial	52	Multiplication And Division Of The Algebraic Fractions	72
Finding Remainder Without Dividing	49	Multiplication And Division Of Two Surds	23
Formulae	13	Multiplication Of Matrices	145
Four Angles Of A Rectangle Are Right Angles	204	Multiplicative Inverse	158
Four Angles Of A Square Are Right Angles	203	Multiplicative Inverse Of A Matrix	156
Four Sides Of A Square Are Equal	202		
Fundamentals Of Geometry	175	N	
H		Non-singular Matrix	157
H.C.F By Division	61	O	
H.C.F. By Factorization Method	58	Obtuse Angle	177
Hemispheres	268	Opposite Sides Of A Rectangle Are Equal	203
Highest Common Factor (HCF) And Least Common Multiple (LCM)	58	Order Of A Matrix	130
I		P	
Improper Rational Expression	3	Parallel Lines	187
Inequalities ($>$, $<$) And ($>$, $<$)	98	Parallelogram	231
Introduction To Coordinate Geometry	275	Perpendicular Bisectors Of The Sides Of A Triangle	227
Inverse Of A Non-singular Matrix	160	Problems Involving Quadratic Equations	121
Irrational Numbers	21	Proper Rational Expression	3
L		Properties Of A Parallelogram	205
L.C.M. By Factorization	64	Properties Of Angles	210
Laws Of Addition Of Matrices	141	Properties Of Congruency	202
Laws Of Radicals	22	Properties Of Congruency Between Two Triangles	198
Least Common Multiple (L.C.M)	64	Properties Of Inequalities	99
Linear Equation In One Variable	86	Properties Of Parallel Lines	187
Linear Equations	86	Pure Surds	22
Linear Inequalities	98	Pythagoras Theorem	248
Linear Polynomials	36	Q	
M		Quadratic Equations	108
Major Arc	208	Quadratic Polynomials	36
Matrices And Determinants	127	Quadrilaterals	202
Matrix Equality	131	R	
Matrix Inversion Method	165	Radius	206
Medians Of A Triangle	228	Rational Expression	2

INDEX

Rational Expression In Its Lowest Terms	4	Surds	21
Rational Numbers	21	Surds of Radicals	21
Rationalization	27	Surds Of Second Order	23
Rationalizing Factor	27	Symbol	196
Rationalizing Of Surds	28	Symmetric Matrix	135
Rationalizing The Denominator	24		
Real Numbers	21	T	
Rectangle	230	Tangent	209
Rectangular Matrix	133	Tangent To A Circle	233
Reduce A Rational Expression To Its Lowest Terms	5	Tangent To Two Un-equal Intersecting Circles	240
Reflex Angle	177	Tangent To Two Un-equal Touching Circles	239
Relation Between The Pairs of angles	191	The Area Of A Rectangle When Its Two Sides Are Given	255
Remainder Theorem And Factor Theorem	47	The Area Of A Triangle	252
Right Angle	177	The Area Of A Triangle When Base And Altitude Is Given	253
Right Circular Cone	266	The Factor Theorem	50
Row Matrix	133	The Quadratic Formula	115
		The Remainder Theorem	48
S		The Sphere	267
Scalar Matrix	134	To Draw Angle-bisectors Of A Triangle	224
Secant Line	209	Transitive	100
Sector	209	Transpose Of A Matrix	135
Semi Circle	208	Transverse Common Tangent Or Internal Tangent	236
Similar Figures	195	Trichotomy	99
Similar Surds	23	Types Of Matrices	133
Singular And Non-singular Matrices	157		
Singular Matrix	157	U	
Skew-symmetric Matrix	136	Unit Matrix Or Identity Matrix	134
Solution Of A Linear Equation	87	Use Of Distance Formula	283
Solution Of A Quadratic Equation	108	Transverse	189
Solution Of A Quadratic Equation By Completing The Square Method	110		
Solution Of A Quadratic Equation By Factorization	108	V	
Solution Of Simultaneous Linear Equations	165	Value Of An Algebraic Expression	10
Solving Linear Inequalities	101	Vertical Angles	181
Square	231	Volume	264
Square Matrix	133	Volume Of Right Circular Cylinder	266
Square Root By Division Method	79		
Square Root By Factorization Method	75	Z	
Square Root Of Algebraic Expression	75	Zero Or Null Matrix	134
Straight Angle	176	Zeros Of Polynomial	50
Subtraction Of Matrices	138		
Sum, Difference And Product Of Rational Expressions	6		
Supplementary Angles	179		

About the Authors

The Author of this book Prof. Dr. Muhammad Ozair Ahmed, Chairman, Department of Mathematics, University of Engineering and Technology (UET) Lahore, has completed his Ph.D from University of Western Ontario, Canada. Beside his 4 years teaching experience in colleges, has 30 years experience of teaching in University. He also taught as teaching Assistant in University of Western Ontario Canada. He has been the President of Punjab Mathematical Society and attended many National and International Seminars on Mathematics.

Before joining UET in 1980 as Lecturer he taught as Lecturer in Govt. College Garhi Dopatta Azad Kashmir and Talimat-e-Alia Girls College Rawalpindi. Then he taught at UET as Assistant Professor, Associate Professor and Professor of Mathematics and Presently he is working as the Chairman Department of Mathematics, UET Lahore.

Mr. Maqsood Raza Ahmad, Associate Professor of Mathematics obtained the Degree of M.Sc in Applied Mathematics from University of the Punjab, Lahore, securing first Position in the Government College, Lahore and was awarded Roll of Honour. In 1979 he joined as lecturer in the Department of Mathematics, University of Balochistan Quetta. There he taught M.Sc classes for a period of almost one year. After having selection by P.P.S.C he appointed in College Cadre in the late 1980. In 1982, he was awarded Postgraduate Scholarship for Bulgaria. In 1990 he was nominated for Commonwealth Scholarship for Postgraduate Studies. In 1994 he was awarded the degree of M.Phil (Fluid Dynamics) by the University of Engineering and Technology, Lahore. The Publications Mr. Maqsood Raza Ahmad has to his credit includes six research papers of postgraduate level in the field of fluid dynamics and more than 20 books of Primary, Middle, Secondary and Intermediate Level. He is presently teaching at Government Shalimar Degree College, Baghbanpura Lahore.



Everybody is sitting in one room whereas the whole house is fully lit.

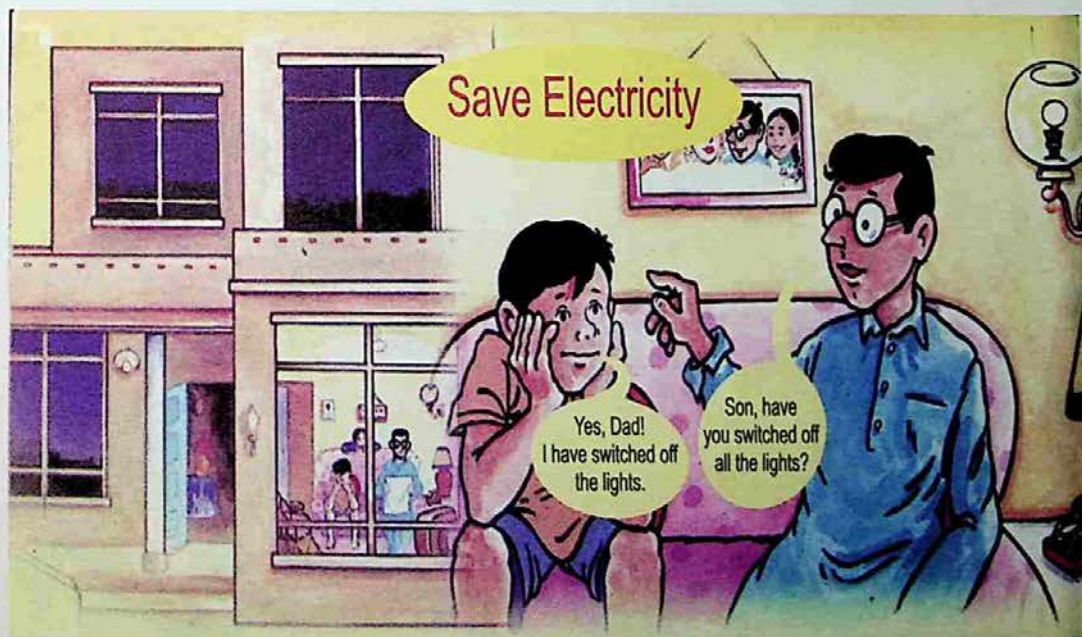

Publisher's Note

This book is being Published in Accordance with National Curriculum 2006 and National Textbook and Learning Materials Policy 2007 as per International Standards. This book has been Selected by Government of the Punjab as sole Textbook for adoption and distribution in all Government Schools in Punjab.