

MATHEMATICS

8



**PUNJAB CURRICULUM AND
TEXTBOOK BOARD, LAHORE**

All rights reserved with the **Punjab Curriculum and Textbook Board, Lahore.**

No part of this book can be copied, translated, reproduced or used for presentation of test papers, guide books, key notes, help books, etc.

Authors

- Prof. Muhammad Amin
- Prof. M. A. Saeed
- Muhammad Ishfaq Baig
- Dr. Shafiq-ur-Rehman
- Muhammad Anwar
- Muhammad Akhtar Shirani

Editor

- Faheem Hussain

Review Committee

- Dr. Akbar Ali
- Prof. Muneer Ahmad Chaudhary

Review Committee for NOC

- Prof. Dr. A.R. Shakoori
Director School of Biological Sciences
Punjab University, Lahore
- Mr. Muhammad Shakoor
Ex-Principal, Crescent Model High
School, Lahore

Supervision

- Muhammad Akhtar Shirani
Subject Specialist

Artist

- Aysha Waheed

Composing and Layout

- Muhammad Azam
- Atif Majeed

Published by: Newage publisher, Lahore

Printed by: Ashiq Shahzeb Printers Lahore

Date of Printing	Edition	Impression	No. of Copies	price
March 2017	1st	2nd	14000	70

Preface

This book is designed in order to continue the pace of gradual development of concepts in Mathematics as determined by National Curriculum 2006 for Mathematics I to XII. It is the revised edition of Mathematics-8 which was developed according to curriculum 2002. It has now been aligned with the National Curriculum 2006.

Before printing, this book was thoroughly reviewed by a committee of well-known experts to seek its valuable recommendations which have been duly incorporated in the book. On finding it fully aligned with the National Curriculum 2006, the review committee recommended it for its printing and publication.

We wish that this book should prove to be an ideal choice for the students looking for a supplement to promote their potentials in the field of Mathematics. As there is always a room for improvement, we cordially invite the valuable suggestions for improvement of the text of this book.

(Authors)

CONTENTS

Units	Topics	Page
1.	Operations on Sets	1
2.	Real Numbers	16
3.	Number Systems	39
4.	Financial Arithmetic	54
5.	Polynomials	89
6.	Factorization, Simultaneous Equations	98
7.	Fundamentals of Geometry	122
8.	Practical Geometry	136
9.	Areas and Volumes	150
10.	Demonstrative Geometry	168
11.	Introduction to Trigonometry	179
12.	Information Handling	188
i.	Answers	203
ii.	Glossary	214
iii.	Symbols	216

Unit - 1



Operations on Sets

After completion of this unit, the students will be able to:

- Recognize set of
 - Natural Numbers (N)
 - Whole Numbers (W)
 - Integers (Z)
 - Rational Numbers (Q)
 - Even Numbers (E)
 - Odd Numbers (O)
 - Prime Numbers (P)
- Find a subset of a set.
- Define proper (\subset) and improper (\subseteq) subset of a set
- Find power set $P(A)$ of a set A
- Verify commutative and associative laws with respect to union and intersection
- Verify the distributive laws
- State and verify De Morgan's laws
- Demonstrate union and intersection of three overlapping sets through Venn diagram.
- Verify associative and distributive laws through Venn diagram

1.1 SETS

We know that a set is a collection of well defined distinct objects or symbols. The objects are called its members or elements.

1.1.1 Recognize some important sets and their notations

Set of natural numbers: $N = \{1, 2, 3, \dots\}$

Set of whole numbers: $W = \{0, 1, 2, \dots\}$

Set of integers: $Z = \{\dots, -3, -2, -1, 0, 1, 2, 3, \dots\}$

Set of prime numbers: $P = \{2, 3, 5, 7, 11, \dots\}$

Set of odd numbers: $O = \{\pm 1, \pm 3, \pm 5, \dots\}$

Set of even numbers: $E = \{0, \pm 2, \pm 4, \dots\}$

Set of rational numbers: $Q = \left\{ \frac{p}{q} \mid p, q \in Z, q \neq 0 \right\}$

1.1.2 Finding subsets of a set

It is illustrated through the following examples.

Example 1: Write all the subsets of the set $\{2, 4\}$

Solution: Following are the subsets of the set $\{2, 4\}$

$$\phi, \{2\}, \{4\}, \{2, 4\}$$

Example 2: Write all the subsets of the set $\{3, 5, 7\}$

Solution: Following are the subsets of the set $\{3, 5, 7\}$

$$\phi, \{3\}, \{5\}, \{7\}, \{3, 5\}, \{3, 7\}, \{5, 7\}, \{3, 5, 7\}$$

Example 3: Write all the subsets of the set $X = \{a, b, c, d\}$

Solution: Subsets of X are:

$$\phi, \{a\}, \{b\}, \{c\}, \{d\}, \{a, b\}, \{a, c\}, \{a, d\}, \{b, c\}, \{b, d\}, \{c, d\},$$

$$\{a, b, c\}, \{a, b, d\}, \{b, c, d\}, \{a, c, d\}, \{a, b, c, d\}$$

1.1.3 Definitions

(a) Proper Subset

If A and B are two sets and every element of set A is also an element of set B but at least one element of the set B is not an element of the set A , then the set A is called a proper subset of set B . It is denoted by $A \subset B$ and read as set A is a proper subset of the set B .

For example, if $A = \{1, 2, 3\}$ and $B = \{1, 2, 3, 4\}$ then $A \subset B$.

Remember that:

- (i) Every set is a subset of itself.
- (ii) Empty set is a proper subset of every non-empty set.

(b) Improper Subset

If A and B are two sets and set A is a subset of set B and B is also a subset of set A then A is called an improper subset of set B and B is an improper subset of set A .

- Note:**
- (i) All the subsets of a set except the set itself are proper subsets of the set.
 - (ii) Procedure of writing subsets of a given set: First of all write empty set, then singleton sets, (a set containing one element only is called singleton set) then sets having two members and so on. Continue till the number of elements becomes equal to the given set.
 - (iii) Every set is an improper subset of itself.
 - (iv) There is no proper subset of an empty set.
 - (v) There is only one proper subset of a singleton set.

1.1.4 Power Set

A set consisting of all possible subsets of a given set A is called the power set of A and is denoted by $P(A)$.

For example, if $A = \{a, b\}$, then all its subsets are:

$$\phi, \{a\}, \{b\}, \{a, b\}$$

So, power set of A , $P(A) = \{\phi, \{a\}, \{b\}, \{a, b\}\}$

Example 4: Write the power set of $B = \{3, 6, 9\}$

Solution: $P(B) = \{\phi, \{3\}, \{6\}, \{9\}, \{3, 6\}, \{3, 9\}, \{6, 9\}, \{3, 6, 9\}\}$

Remember that:

If a set contains n elements, then the number of all its subsets will be 2^n :
 For example, if $X = \{1, 2, 3\}$ then all its subsets are $\phi, \{1\}, \{2\}, \{3\}, \{1, 2\}, \{2, 3\}, \{1, 3\}, \{1, 2, 3\}$ which are 8 in number and $2^3 = 8$

Can you tell?

If a set A consists of 4 elements, then how many elements are in $P(A)$?

Note that:

- * The members of $P(A)$ are all subsets of set A i.e. $\{a\} \in P(A)$ but $a \notin P(A)$.
- * The power set of ϕ is not empty as number of subsets of ϕ is $2^0 = 1$
 i.e. $P(\phi) = \{\phi\}$ or $\{\{\}\}$

EXERCISE 1.1

1. Write all subsets of the following sets.

(i) $\{ \}$	(ii) $\{ 1 \}$	(iii) $\{a, b\}$
-------------	----------------	------------------
2. Write all proper subsets of the following sets.

(i) $\{a\}$	(ii) $\{0, 1\}$	(iii) $\{1, 2, 3\}$
-------------	-----------------	---------------------
3. Write the power set of the following sets.

(i) $\{-1, 1\}$	(ii) $\{a, b, c\}$
-----------------	--------------------

1.2 OPERATIONS ON SETS

1.2.1 Verification of Commutative and Associative Laws with respect to Union and Intersection

- **Commutative Laws of Union and Intersection on Sets**

If A and B are two sets then the commutative laws with respect to union and intersection are written as:

- (i) $A \cup B = B \cup A$ (Commutative law of union)
- (ii) $A \cap B = B \cap A$ (Commutative law of intersection)

Example 1: If $A = \{1, 2, 3, \dots, 10\}$ and $B = \{3, 5, 7, 9\}$

(i) Verify the commutative law of union

(ii) Verify the commutative law of intersection

Solution: $A = \{1, 2, 3, \dots, 10\}, B = \{3, 5, 7, 9\}$

$$(i) \quad A \cup B = \{1, 2, 3, \dots, 10\} \cup \{3, 5, 7, 9\} \\ = \{1, 2, 3, \dots, 10\}$$

$$B \cup A = \{3, 5, 7, 9\} \cup \{1, 2, 3, \dots, 10\} \\ = \{1, 2, 3, \dots, 10\}$$

Therefore, $A \cup B = B \cup A$

$$(ii) \quad A \cap B = \{1, 2, 3, \dots, 10\} \cap \{3, 5, 7, 9\} \\ = \{3, 5, 7, 9\}$$

$$B \cap A = \{3, 5, 7, 9\} \cap \{1, 2, 3, \dots, 10\} \\ = \{3, 5, 7, 9\}$$

Therefore, $A \cap B = B \cap A$

• Associative Laws of Union and Intersection

If A, B and C are three sets then the Associative laws with respect to union and intersection are written respectively as:

$$(i) \quad A \cup (B \cup C) = (A \cup B) \cup C \quad (ii) \quad A \cap (B \cap C) = (A \cap B) \cap C$$

Remember that:

To find union / intersection of three sets, first we find the union / intersection of any two of them and then the union / intersection of the third set with the resultant set.

Example 2: Verify the associative laws of union

$$A \cup (B \cup C) = (A \cup B) \cup C$$

where $A = \{1, 2, 3, 4\}, B = \{3, 4, 5, 6, 7, 8\}$ and $C = \{6, 7, 8, 9, 10\}$

$$\begin{aligned} \text{Solution: } L.H.S = A \cup (B \cup C) &= \{1, 2, 3, 4\} \cup (\{3, 4, 5, 6, 7, 8\} \cup \{6, 7, 8, 9, 10\}) \\ &= \{1, 2, 3, 4\} \cup \{3, 4, 5, 6, 7, 8, 9, 10\} \\ &= \{1, 2, 3, 4, 5, 6, 7, 8, 9, 10\} \quad \dots\dots\dots (1) \end{aligned}$$

$$\begin{aligned}
 R.H.S &= (A \cup B) \cup C = (\{1, 2, 3, 4\} \cup \{3, 4, 5, 6, 7, 8\}) \cup \{6, 7, 8, 9, 10\} \\
 &= \{1, 2, 3, 4, 5, 6, 7, 8\} \cup \{6, 7, 8, 9, 10\} \\
 &= \{1, 2, 3, 4, 5, 6, 7, 8, 9, 10\} \dots\dots\dots (2)
 \end{aligned}$$

Thus, from (1) and (2), we conclude that $A \cup (B \cup C) = (A \cup B) \cup C$

Example 3: Verify the associative laws of intersection

$$A \cap (B \cap C) = (A \cap B) \cap C \text{ for sets given in example 1.}$$

Solution: $L.H.S = A \cap (B \cap C) = \{1, 2, 3, 4\} \cap (\{3, 4, 5, 6, 7, 8\} \cap \{6, 7, 8, 9, 10\})$
 $= \{1, 2, 3, 4\} \cap \{6, 7, 8\}$
 $= \phi \dots\dots\dots (a)$

$R.H.S = (A \cap B) \cap C = (\{1, 2, 3, 4\} \cap \{3, 4, 5, 6, 7, 8\}) \cap \{6, 7, 8, 9, 10\}$
 $= \{3, 4\} \cap \{6, 7, 8, 9, 10\}$
 $= \phi \dots\dots\dots (b)$

Thus, from (a) and (b), we conclude that $A \cap (B \cap C) = (A \cap B) \cap C$

1.2.2 Verification of Distributive Laws

If A, B and C are three sets, then $A \cup (B \cap C) = (A \cup B) \cap (A \cup C)$ is called the distributive law of union over intersection.

If A, B and C are three sets, then $A \cap (B \cup C) = (A \cap B) \cup (A \cap C)$ is called the distributive law of intersection over union.

Example 4: Verify:

- (I) Distributive law of union over intersection
- (II) Distributive law of intersection over union

where $A = \{1, 2, 3, \dots, 20\}$, $B = \{5, 10, 15, \dots, 30\}$ and $C = \{3, 9, 15, 21, 27, 33\}$.

Solution: (I)

$$\begin{aligned}
 L.H.S &= A \cup (B \cap C) = \{1, 2, 3, \dots, 20\} \cup (\{5, 10, 15, \dots, 30\} \cap \{3, 9, 15, 21, 27, 33\}) \\
 &= \{1, 2, 3, \dots, 20\} \cup \{15\}
 \end{aligned}$$

$\therefore A \cup (B \cap C) = \{1, 2, 3, \dots, 20\} \dots\dots\dots (i)$

Now $R.H.S = A \cup B = \{1, 2, 3, \dots, 20\} \cup \{5, 10, 15, \dots, 30\}$
 $= \{1, 2, 3, \dots, 20, 25, 30\}$

and $A \cup C = \{1, 2, 3, \dots, 20\} \cup \{3, 9, 15, 21, 27, 33\}$
 $= \{1, 2, 3, \dots, 20, 21, 27, 33\}$

$$(A \cup B) \cap (A \cup C) = \{1, 2, 3, 4, \dots, 20, 25, 30\} \cap \{1, 2, 3, \dots, 20, 21, 27, 33\}$$

$\therefore (A \cup B) \cap (A \cup C) = \{1, 2, 3, \dots, 20\} \dots\dots\dots (ii)$

Thus, from (i) and (ii), we conclude that $A \cup (B \cap C) = (A \cup B) \cap (A \cup C)$

$$(II) \quad L.H.S = A \cap (B \cup C) = \{1, 2, 3, \dots, 20\} \cap (\{5, 10, 15, \dots, 30\} \cup \{3, 9, 15, 21, 27, 33\})$$

$$= \{1, 2, 3, \dots, 20\} \cap \{3, 5, 9, 10, 15, 20, 21, 25, 27, 30, 33\}$$

$$\therefore \quad A \cap (B \cup C) = \{3, 5, 9, 10, 15, 20\} \quad \dots\dots\dots (i)$$

$$R.H.S = A \cap B = \{1, 2, 3, \dots, 20\} \cap \{5, 10, 15, \dots, 30\}$$

$$= \{5, 10, 15, 20\}$$

$$A \cap C = \{1, 2, 3, \dots, 20\} \cap \{3, 9, 15, 21, 27, 33\}$$

$$= \{3, 9, 15\}$$

$$(A \cap B) \cup (A \cap C) = \{5, 10, 15, 20\} \cup \{3, 9, 15\}$$

$$\therefore \quad (A \cap B) \cup (A \cap C) = \{3, 5, 9, 10, 15, 20\} \quad \dots\dots\dots (ii)$$

Thus, from (i) and (ii), we conclude that $A \cap (B \cup C) = (A \cap B) \cup (A \cap C)$

1.2.3 De Morgan's Laws

If A and B are the subsets of a universal set U , then

$$(i) \quad (A \cup B)^c = A^c \cap B^c \quad (ii) \quad (A \cap B)^c = A^c \cup B^c$$

Example 5: Verify De Morgan's Laws if:

$$U = \{1, 2, 3, \dots, 10\}, \quad A = \{2, 4, 6\} \quad \text{and} \quad B = \{1, 2, 3, 4, 5, 6, 7\}$$

Solution: (i) $L.H.S = (A \cup B)^c$

$$A \cup B = \{2, 4, 6\} \cup \{1, 2, 3, 4, 5, 6, 7\}$$

$$= \{1, 2, 3, 4, 5, 6, 7\}$$

$$\therefore \quad (A \cup B)^c = U - (A \cup B) = \{8, 9, 10\} \quad \dots\dots\dots (i)$$

$$R.H.S = A^c \cap B^c$$

$$A^c = U - A$$

$$= \{1, 2, 3, \dots, 10\} - \{2, 4, 6\}$$

$$= \{1, 3, 5, 7, 8, 9, 10\}$$

$$B^c = U - B$$

$$= \{1, 2, 3, \dots, 10\} - \{1, 2, 3, 4, 5, 6, 7\}$$

$$= \{8, 9, 10\}$$

$$\therefore \quad A^c \cap B^c = \{1, 3, 5, 7, 8, 9, 10\} \cap \{8, 9, 10\}$$

$$= \{8, 9, 10\} \quad \dots\dots\dots (ii)$$

Thus, from (i) and (ii) we have $(A \cup B)^c = A^c \cap B^c$



August De Morgan (1806-1871), a British mathematician who formulated De Morgan's laws.

$$\begin{aligned}
 \text{(ii)} \quad L.H.S &= (A \cap B)^c \\
 A \cap B &= \{2, 4, 6\} \cap \{1, 2, 3, 4, 5, 6, 7\} \\
 &= \{2, 4, 6\} \\
 (A \cap B)^c &= U - (A \cap B) \\
 &= \{1, 2, 3, \dots, 10\} - \{2, 4, 6\} \\
 &= \{1, 3, 5, 7, 8, 9, 10\} \quad \dots\dots \text{(iii)}
 \end{aligned}$$

$$\begin{aligned}
 R.H.S &= A^c = U - A = \{1, 2, 3, \dots, 10\} - \{2, 4, 6\} \\
 &= \{1, 3, 5, 7, 8, 9, 10\}
 \end{aligned}$$

$$\begin{aligned}
 \text{and} \quad B^c &= U - B = \{1, 2, 3, \dots, 10\} - \{1, 2, 3, 4, 5, 6, 7\} \\
 &= \{8, 9, 10\}
 \end{aligned}$$

$$\begin{aligned}
 \therefore A^c \cup B^c &= \{1, 3, 5, 7, 8, 9, 10\} \cup \{8, 9, 10\} \\
 &= \{1, 3, 5, 7, 8, 9, 10\} \quad \dots\dots \text{(iv)}
 \end{aligned}$$

Thus, from (iii) and (iv) , we have $(A \cap B)^c = A^c \cup B^c$

EXERCISE 1.2

1. Verify:

(a) $A \cup B = B \cup A$ and (b) $A \cap B = B \cap A$, when

(i) $A = \{1, 2, 3, \dots, 10\}$, $B = \{7, 8, 9, 10, 11, 12\}$

(ii) $A = \{1, 2, 3, \dots, 15\}$, $B = \{6, 8, 10, \dots, 20\}$

2. Verify:

(a) $X \cup (Y \cap Z) = (X \cup Y) \cap Z$ and (b) $X \cap (Y \cup Z) = (X \cap Y) \cup Z$, when

(i) $X = \{a, b, c, d\}$, $Y = \{b, d, c, f\}$ and $Z = \{c, f, g, h\}$

(ii) $X = \{1, 2, 3, \dots, 10\}$, $Y = \{2, 4, 6, 7, 8\}$ and $Z = \{5, 6, 7, 8\}$

(iii) $X = \{-1, 0, 2, 4, 5\}$, $Y = \{1, 2, 3, 4, 7\}$ and $Z = \{4, 6, 8, 10\}$

(iv) $X = \{1, 2, 3, \dots, 14\}$, $Y = \{6, 8, 10, \dots, 20\}$ and $Z = \{1, 3, 5, 7\}$

3. Show that:

if $A = \{a, b, c\}$, $B = \{b, d, f\}$ and $C = \{a, f, c\}$,

$$A \cup (B \cap C) = (A \cup B) \cap (A \cup C)$$

4. Show that:

if $A = \{0\}$, $B = \{0, 1\}$ and $C = \{ \}$,

$$A \cup (B \cap C) = (A \cup B) \cap (A \cup C)$$

5. Verify De Morgan's Laws if:

$U = N$, $A = \phi$, and $B = P$

1.3 VENN DIAGRAM

Operations on Sets Through Venn-diagram

A universal set is represented in the form of a rectangle, its subsets are represented in the form of closed figures inside the rectangle. Adjoining figure

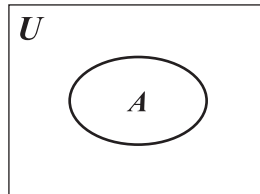

is the representation for $A \subseteq U$ through Venn-diagram.

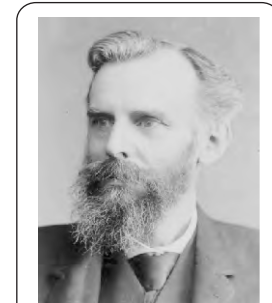

John Venn (1834-1923), an English mathematician who introduced Venn diagrams.

1.3.1 Demonstration of Union and Intersection of three overlapping sets through Venn diagram

(i) $A \cup (B \cup C)$

In fig. (i) set $B \cup C$ is represented by horizontal lines and set $A \cup (B \cup C)$ is represented by vertical lines. Thus, $A \cup (B \cup C)$ is represented by double lines and single lines.

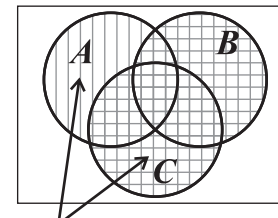

$A \cup (B \cup C)$ Fig.(i)

(ii) $A \cup (B \cap C)$

In fig. (ii) set $B \cap C$ is represented by horizontal lines and set $A \cup (B \cap C)$ is represented by vertical lines. Thus, $A \cup (B \cap C)$ is represented by double lines and single lines.

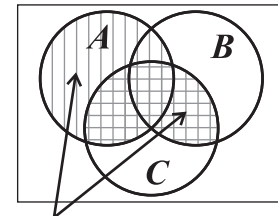

$A \cup (B \cap C)$ Fig.(ii)

(iii) $A \cap (B \cup C)$

In fig. (iii) set $B \cup C$ is represented by horizontal lines and set $A \cap (B \cup C)$ is represented by vertical lines. Thus, $A \cap (B \cup C)$ is represented only by double lines i.e, small boxes.

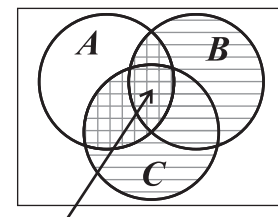

$A \cap (B \cup C)$ Fig.(iii)

(iv) $A \cap (B \cap C)$

In fig. (iv) set $B \cap C$ is represented by horizontal lines and set $A \cap (B \cap C)$ is represented by vertical lines. Thus, $A \cap (B \cap C)$ is represented only by double lines.

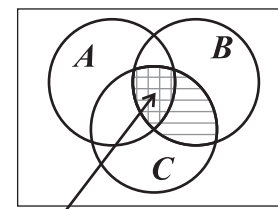

$A \cap (B \cap C)$ Fig.(iv)

1.3.2 Verify associative and distributive laws through Venn diagram

• **Associative Laws**

(a) Associative Law of Union

$$A \cup (B \cup C) = (A \cup B) \cup C$$

Let $A = \{1, 3, 5, 7, 9, 10\}$, $B = \{2, 4, 6, 8, 9, 10\}$ and $C = \{2, 3, 5, 7, 11, 13\}$

$$L.H.S = A \cup (B \cup C)$$

$$B \cup C = \{2, 4, 6, 8, 9, 10\} \cup \{2, 3, 5, 7, 11, 13\}$$

$$= \{2, 3, 4, 5, 6, 7, 8, 9, 10, 11, 13\}$$

$$A \cup (B \cup C) = \{1, 3, 5, 7, 9, 10\} \cup \{2, 3, 4, 5, 6, 7, 8, 9, 10, 11, 13\}$$

$$= \{1, 2, 3, 4, 5, 6, 7, 8, 9, 10, 11, 13\}$$

$$R.H.S = (A \cup B) \cup C$$

$$A \cup B = \{1, 3, 5, 7, 9, 10\} \cup \{2, 4, 6, 8, 9, 10\}$$

$$= \{1, 2, 3, 4, 5, 6, 7, 8, 9, 10\}$$

$$(A \cup B) \cup C = \{1, 2, 3, 4, 5, 6, 7, 8, 9, 10\} \cup \{2, 3, 5, 7, 11, 13\}$$

$$= \{1, 2, 3, 4, 5, 6, 7, 8, 9, 10, 11, 13\}$$

From fig. (v) and (vi), it is clear that

$$A \cup (B \cup C) = (A \cup B) \cup C$$

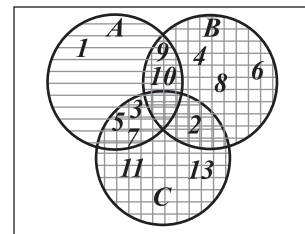

Fig. (v)

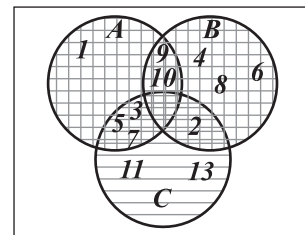

Fig. (vi)

(b) Associative Law of Intersection

$$A \cap (B \cap C) = (A \cap B) \cap C$$

$A = \{1, 3, 5, 7, 9, 10\}$, $B = \{2, 4, 6, 8, 9, 10\}$ and $C = \{2, 3, 5, 7, 11, 13\}$

$$L.H.S = A \cap (B \cap C)$$

$$B \cap C = \{2, 4, 6, 8, 9, 10\} \cap \{2, 3, 5, 7, 11, 13\} = \{2\}$$

$$A \cap (B \cap C) = \{1, 3, 5, 7, 9, 10\} \cap \{2\} = \{ \}$$

Horizontal lines represent $B \cap C$ and vertical lines represent $A \cap (B \cap C)$. Thus, $A \cap (B \cap C) = \{ \}$

$$R.H.S = (A \cap B) \cap C$$

$$A \cap B = \{1, 3, 5, 7, 9, 10\} \cap \{2, 4, 6, 8, 9, 10\} = \{9, 10\}$$

$$(A \cap B) \cap C = \{9, 10\} \cap \{2, 3, 5, 7, 11, 13\} = \{ \}$$

Horizontal lines represent $A \cap B$ and vertical lines represent $(A \cap B) \cap C$. Thus, $(A \cap B) \cap C = \{ \}$

From fig. (vii) and (viii), it is clear that $A \cap (B \cap C) = (A \cap B) \cap C$

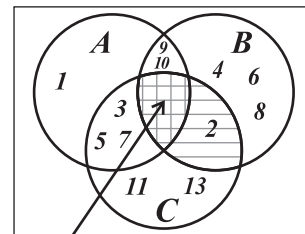

$A \cap (B \cap C)$ Fig. (vii)

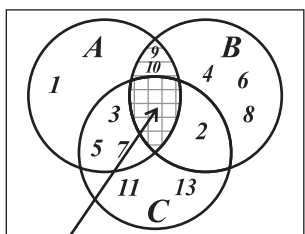

$(A \cap B) \cap C$ Fig. (viii)

• **Distributive Laws**

(a) **Distributive Law of Intersection over Union**

$$A \cap (B \cup C) = (A \cap B) \cup (A \cap C)$$

Let $A = \{1, 3, 5, 7, 9, 10\}$, $B = \{2, 4, 6, 8, 9, 10\}$

and $C = \{2, 3, 5, 7, 11, 13\}$

$$L.H.S = A \cap (B \cup C)$$

$$B \cup C = \{2, 4, 6, 8, 9, 10\} \cup \{2, 3, 5, 7, 11, 13\}$$

$$= \{2, 3, 4, 5, 6, 7, 8, 9, 10, 11, 13\}$$

$$A \cap (B \cup C) = \{1, 3, 5, 7, 9, 10\} \cap \{2, 3, 4, 5, 6, 7, 8, 9, 10, 11, 13\} = \{3, 5, 7, 9, 10\}$$

Horizontal lines represent $B \cup C$ and vertical lines represent $A \cap (B \cup C)$. Thus, slanting lines represent $A \cap (B \cup C)$.

$$R.H.S = (A \cap B) \cup (A \cap C)$$

$$A \cap B = \{1, 3, 5, 7, 9, 10\} \cap \{2, 4, 6, 8, 9, 10\} = \{9, 10\}$$

$$A \cap C = \{1, 3, 5, 7, 9, 10\} \cap \{2, 3, 5, 7, 11, 13\} = \{3, 5, 7\}$$

$$\therefore (A \cap B) \cup (A \cap C) = \{9, 10\} \cup \{3, 5, 7\} = \{3, 5, 7, 9, 10\}$$

Horizontal lines represent $A \cap B$, vertical lines represent $A \cap C$ and slanting lines represent $(A \cap B) \cup (A \cap C)$.

From fig. (ix) and (x), it is clear that $A \cap (B \cup C) = (A \cap B) \cup (A \cap C)$

Hence distributive law of intersection over union holds.

(b) **Distributive Law of Union over Intersection**

$$A \cup (B \cap C) = (A \cup B) \cap (A \cup C)$$

$A = \{1, 3, 5, 7, 9, 10\}$, $B = \{2, 4, 6, 8, 9, 10\}$ and $C = \{2, 3, 5, 7, 11, 13\}$

$$L.H.S = A \cup (B \cap C)$$

$$B \cap C = \{2, 4, 6, 8, 10\} \cap \{2, 3, 5, 7, 11, 13\} = \{2\}$$

Horizontal lines represent $B \cap C$, vertical lines represent $A \cup (B \cap C)$. Thus, slanting lines represent $A \cup (B \cap C)$.

$$A \cup (B \cap C) = \{1, 3, 5, 7, 9, 10\} \cup \{2\} = \{1, 2, 3, 5, 7, 9, 10\}$$

$$R.H.S = (A \cup B) \cap (A \cup C)$$

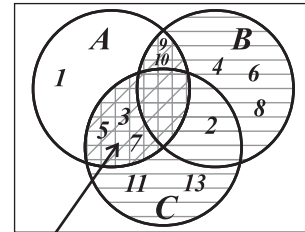

$A \cap (B \cup C)$ Fig. (ix)

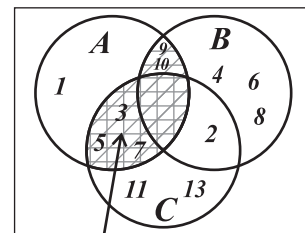

$(A \cap B) \cup (A \cap C)$ Fig. (x)

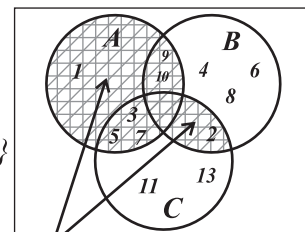

$A \cup (B \cap C)$ Fig. (xi)

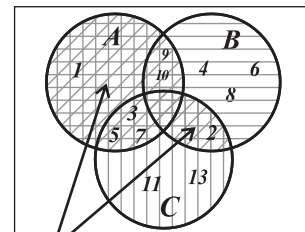

$(A \cup B) \cap (A \cup C)$ Fig. (xii)

$$A \cup B = \{1, 3, 5, 7, 9, 10\} \cup \{2, 4, 6, 8, 9, 10\} = \{1, 2, 3, 4, 5, 6, 7, 8, 9, 10\}$$

$$A \cup C = \{1, 3, 5, 7, 9, 10\} \cup \{2, 3, 5, 7, 11, 13\} = \{1, 2, 3, 5, 7, 9, 10, 11, 13\}$$

$$(A \cup B) \cap (A \cup C) = \{1, 2, 3, 4, 5, 6, 7, 8, 9, 10\} \cap \{1, 2, 3, 5, 7, 9, 10, 11, 13\} \\ = \{1, 2, 3, 5, 7, 9, 10\}$$

Horizontal lines represent $A \cup B$, vertical lines represent $A \cup C$ and slanting lines represent $(A \cup B) \cap (A \cup C)$. From fig. (xi) and (xii), it is clear that $A \cup (B \cap C) = (A \cup B) \cap (A \cup C)$. Hence, distributive law of union over intersection holds.

EXERCISE 1.3

1. Verify the commutative law of union and intersection of the following sets through Venn diagrams.

(i) $A = \{3, 5, 7, 9, 11, 13\}$ (ii) The sets N and Z

$B = \{5, 9, 13, 17, 21, 25\}$

(iii) $C = \{x \mid x \in N \wedge 8 \leq x \leq 18\}$ (iv) The sets E and O

$D = \{y \mid y \in N \wedge 9 \leq y \leq 19\}$

2. Copy the following figures and shade according to the operation mentioned below each:

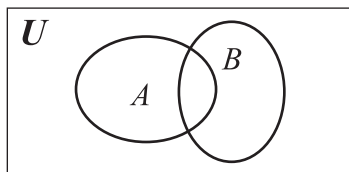

$A \cup B$

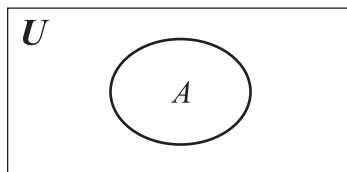

$U \cup A$

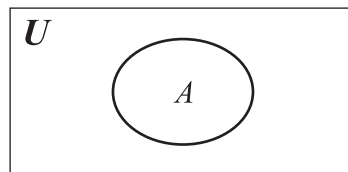

$A \cup A$

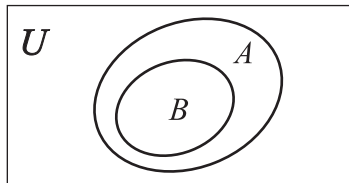

$A \cap B$

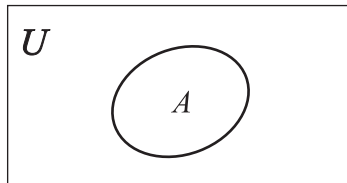

$U \cap A$

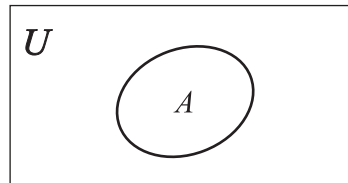

$A \cap A$

3. For the given sets, verify the following laws through venn diagram.

(i) Associative law of Union of sets.

(ii) Associative law of Intersection of sets.

(iii) Distributive law of Union over intersection of sets.

(iv) Distributive law of Intersection over Union of sets.

(a) $A = \{2, 4, 6, 8, 10, 12\}$, $B = \{1, 3, 5, 7, 9, 11\}$ and $C = \{3, 6, 9, 12, 15\}$

(b) $A = \{x \mid x \in Z \wedge 8 \leq x \leq 25\}$, $B = \{y \mid y \in Z \wedge -2 < y < 6\}$ and $C = \{z \mid z \in Z \wedge z \leq 8\}$

4. Copy the following Venn diagrams and shade according to the operation, given below each diagram.

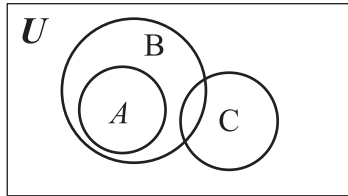

$$(A \cap B) \cup C$$

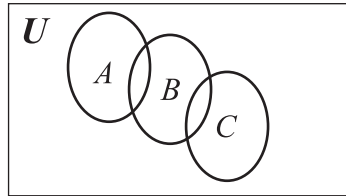

$$(A \cup B) \cap C$$

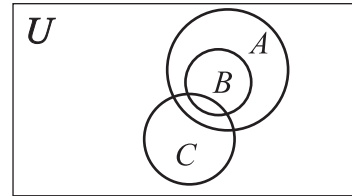

$$(A \cap B) \cup C$$

REVIEW EXERCISE 1

1. Four options are given against each statement. Encircle the correct one.
 - i. If a is not a member of the set A , then symbolically it is denoted by:

(a) $a \in A$ (b) $a \setminus A$ (c) $a \notin A$ (d) $a \cap A$
 - ii. Which of the following is not a set?

(a) $\{1, 2, 3\}$ (b) $\{a, b, c\}$ (c) $\{2, 3, 4\}$ (d) $\{1, 2, 2, 3\}$
 - iii. The number of subsets of the set $\{0\}$ is:

(a) one (b) two (c) three (d) four
 - iv. A set consisting of all subsets of the set X is called:

(a) subset (b) universal set (c) power set (d) super set
 - v. For three sets A, B and C , $(A \cup B) \cup C$ is equal to:

(a) $(A \cup B) \cap C$ (b) $(A \cap B)$ (c) $A \cup (B \cup C)$ (d) $(A \cap B) \cap C$
 - vi. For any two sets A and B , $A - B^c$ is equal to:

(a) $A \cap B^c$ (b) $A^c \cap B$ (c) $A \cap B$ (d) $A \cup B$
 - vii. If $U = \{1, 2, 3, \dots, 10\}$ and $A = \{2, 4, 6, \dots, 10\}$ and $B = \{1, 3, 5, \dots, 9\}$ then $(A - B)^c$ is equal to:

(a) U (b) B (c) A (d) ϕ
 - viii. If $P(A) = \{\phi, \{a\}, \{b\}, \{a, b\}\}$ then set A is equal to:

(a) ϕ (b) $\{a\}$ (c) $\{b\}$ (d) $\{a, b\}$
 - ix. If ϕ is an empty set, then $(\phi^c)^c$ is equal to:

(a) X (b) O (c) ϕ (d) $\{0\}$

2. Write the short answers of the following questions.
- Define a set.
 - What is the difference between whole numbers and natural numbers?
 - Define the proper and improper subsets.
 - Define a power set.
 - Define De Morgan's Laws.
3. Write all subsets of the following sets.
- $A = \{e, f, g\}$ and $B = \{1, 3, 5\}$
 - Write the power set of $\{a, b, c\}$
 - Verify De Morgan's Laws if
 $U = \{a, b, c, d, e\}$, $A = \{d, e\}$ and $B = \{a, b, c\}$

SUMMARY

- Set is defined as "a collection of well defined distinct objects". These objects are called elements or members of a set.
- A set A is a subset of a set B if every element in set A is also an element in set B .
- The empty set is a subset of all sets.
- If A is a subset of B and A is not equal to B (i.e. there exists at least one element of B not contained in A), then A is a proper subset of B , denoted by $A \subset B$.
- If A is a subset of B and A is equal to B (i.e. every element of B is also the element of A), then A is an improper subset of B , denoted by $A = B$.
- Intersection of two sets $A \cap B$, is a set which consist of only the common elements of both A and B .
- Union of two sets $A \cup B$, is a set which consists of elements of both A and B with common elements represented only once.
- If A and B are any two sets, then
 - $A \cup B = B \cup A$ (Commutative law over union)
 - $A \cap B = B \cap A$ (Commutative law over intersection)

- Let A , B and C be any three sets, then
 - i. $A \cup (B \cup C) = (A \cup B) \cup C$ (Associative law of union of sets)
 - ii. $A \cap (B \cap C) = (A \cap B) \cap C$ (Associative law of intersection of sets)
- Let A , B and C be any three sets, then distributive laws are given below
 - i. $A \cup (B \cap C) = (A \cup B) \cap (A \cup C)$
(distributive law of union over intersection)
 - ii. $A \cap (B \cup C) = (A \cap B) \cup (A \cap C)$
(distributive law of intersection over union)
- Let A and B be any two sets then according to the De Morgan's laws.
 - i. $(A \cup B)^c = A^c \cap B^c$
 - ii. $(A \cap B)^c = A^c \cup B^c$
- A Venn diagram is a pictorial representation of sets and operations performed on sets.





After completion of this unit, the students will be able to:

- Define an irrational number.
- Recognize rational and irrational numbers.
- Define real numbers.
- Demonstration of Terminating and Non-Terminating Fractions with Repeating and Non-Repeating decimals
- Find perfect square of a number.
- Establish patterns for the squares of natural numbers
 - (e.g., $4^2 = 1 + 2 + 3 + 4 + 3 + 2 + 1$).
- Find square root of
 - a natural number (e.g., 16, 625, 1600),
 - a common fraction (e.g., $\frac{9}{16}$, $\frac{36}{49}$, $\frac{49}{64}$),
 - a decimal (e.g., 0.01, 1.21, 0.64), given in perfect square form, by prime factorization and division method.
- Find square root of a number which is not a perfect square (e.g., the numbers 2, 3, 2.5).
- Use the following rule to determine the number of digits in the square root of a perfect square.

Rule: Let “ n ” be the number of digits in the perfect square then its square root contains $\frac{n}{2}$ digits if n is even, $\frac{n+1}{2}$ digits if n is odd.
- Solve real life problems involving square roots.
- Recognize cubes and perfect cubes.
- Find cube roots of a number which are perfect cubes.
- Recognize properties of cubes of numbers.

2.1 IRRATIONAL NUMBERS

2.1.1 Definition of an Irrational Number

The numbers which cannot be written in the form $\frac{p}{q}$ where $p, q \in Z$ and $q \neq 0$, are called irrational numbers. We know that there is no such rational number whose square is 2. Therefore, the square root of 2 is not a rational number. Similarly $\sqrt{2}$, $\frac{\sqrt{5}}{7}$ and $\frac{\sqrt{2}}{3}$ are not rational numbers. These are called irrational numbers. The set of irrational numbers is denoted by Q' .

It can also be defined as a number whose decimal representation is non-terminating and non-recurring is called an **irrational** number.

2.1.2 Recognition of Rational and Irrational Numbers

We have already learnt about rational numbers and irrational numbers. Now we recognize these numbers with the help of the following examples.

Example 1: Which of the following numbers are rational numbers?

$$\frac{2}{3}, \sqrt{9}, \frac{-7}{9}, \sqrt{\frac{16}{25}}, \frac{6}{11}, \sqrt{5}, \sqrt{7}, \sqrt{25}$$

Solution: The numbers $\frac{2}{3}$, $\sqrt{9}$, $\frac{-7}{9}$, $\sqrt{\frac{16}{25}}$, $\frac{6}{11}$, and $\sqrt{25}$ are rational numbers because all of these numbers can be expressed in the form of $\frac{p}{q}$, where $p, q \in Z$ and $q \neq 0$.

Example 2: Which of the following numbers are irrational numbers?

$$\sqrt{2}, 1.732050\dots, \sqrt{4}, 2.236067\dots, \sqrt{16}, \sqrt{17}, \sqrt{19}, \sqrt{25}, \sqrt{37}$$

Solution: The numbers $\sqrt{2}$, $1.732050\dots$, $2.236067\dots$, $\sqrt{17}$, $\sqrt{19}$ and $\sqrt{37}$ are irrational numbers because all of these cannot be written in the form of $\frac{p}{q}$,

where $p, q \in Z$ and $q \neq 0$

2.1.3 Real Numbers

Now we define the set of Real Numbers as: "The union of the set of rational numbers Q and the set of irrational numbers Q' is called the set of Real Numbers and is denoted by R . i.e.,

$$R = Q \cup Q'$$

2.1.4 Demonstration of Terminating and Non-Terminating Fractions with Repeating and Non-Repeating decimals

- **Terminating decimal fraction**

The decimal fraction in which the number of digits after the decimal point is finite or while converting a common fraction into the decimal fraction the division process ends, then it is called a terminating decimal fraction. These fractions can easily be converted in the form of $\frac{p}{q}$ (rational numbers), where $p, q \in \mathbb{Z}$ and $q \neq 0$, as 0.25, 3.125 and 0.0625 etc, are also the examples of terminating decimal fractions.

Look at the following example:

Example 3: Convert common fraction $\frac{9}{4}$ to decimal.

Solution:

$$\begin{array}{r}
 2.25 \\
 4 \overline{)9.00} \\
 \underline{-8} \quad \downarrow \\
 10 \quad \downarrow \\
 \underline{-8} \quad \downarrow \\
 20 \\
 \underline{-20} \\
 0
 \end{array}$$

$$\therefore \frac{9}{4} = 2.25$$

- **Non-Terminating with Repeating and Non-Repeating decimal fraction**

The decimal fraction in which the number of digits after the decimal point is infinite or while converting a common fraction into the decimal fraction the division process does not end and none of the digits is being repeated, then it is called a non-terminating and non-repeating decimal fraction.

It can be explained through the following examples:

Example 4: Convert common fraction

$$\frac{1}{9} \text{ to decimal.}$$

Solution:

$$\begin{array}{r} 0.1111\dots \\ 9 \overline{) 1.0000} \\ \underline{-9} \\ 10 \\ \underline{-9} \\ 10 \\ \underline{-9} \\ 10 \\ \underline{-9} \\ 1 \end{array}$$

$$\therefore \frac{1}{9} = 0.1111\dots \text{ (non-terminating and repeating)}$$

Example 5: Convert common fraction

$$\frac{9}{7} \text{ to decimal.}$$

Solution:

$$\begin{array}{r} 1.28571428\dots \\ 7 \overline{) 9.00000000} \\ \underline{-7} \\ 20 \\ \underline{-14} \\ 60 \\ \underline{-56} \\ 40 \\ \underline{-35} \\ 50 \\ \underline{-49} \\ 10 \\ \underline{-7} \\ 30 \\ \underline{-28} \\ 20 \\ \underline{-14} \\ 60 \\ \underline{-56} \\ 4 \end{array}$$

$$\therefore \frac{9}{7} = 1.28571428\dots \text{ (non-terminating and repeating)}$$

We have seen that in Example 3 the decimal 2.25 has terminated/ended after 2 digits and in Example 4, the decimal 0.1111.... non-terminating but repeating.

Whereas in Example 5, the decimal fraction 1.285714... does not end but it goes on forever. These dots (.....) indicate that this decimal fraction is non-terminating and repeating.

Note:

The decimals which are non-terminating and non-repeating are called irrational numbers.

EXERCISE 2.1

1. Convert the following rational numbers into decimal fractions and separate terminating and non-terminating decimals.

(i) $\frac{5}{7}$

(ii) $\frac{3}{5}$

(iii) $\frac{6}{7}$

(iv) $\frac{2}{7}$

(v) $\frac{3}{8}$

(vi) $\frac{8}{5}$

2. Convert the following rational numbers into decimal fractions and separate repeating and non-repeating decimals.

(i) $\frac{3}{7}$

(ii) $\frac{4}{5}$

(iii) $\frac{6}{8}$

(iv) $\frac{11}{12}$

(v) $\frac{1}{7}$

(vi) $\frac{8}{9}$

(vii) $\frac{25}{8}$

(viii) $\frac{22}{7}$

(ix) $\frac{13}{4}$

(x) $\frac{21}{6}$

(xi) $\frac{29}{2}$

(xii) $\frac{10}{3}$

2.2 SQUARES

When a number is multiplied by itself then the product is known as the square of the number i.e, the square of x is $x \times x = x^2$

For Example:

$$3 \times 3 = 3^2 = 9$$

Read as square of 3 is 9

Similarly, $5 \times 5 = 5^2 = 25$

i.e., square of 5 is 25

2.2.1 Finding perfect square of a number

A natural number is called a perfect square, if it is the square of another natural number.

e.g., the number 4 is a perfect square because $4 = 2^2$

Similarly, 25 is a perfect square because $25 = 5^2$ and so on

Now, we learn to find a perfect square of a number:

Example 1: Find the perfect square of 13

Solution:

The perfect square of 13 is

$$\begin{aligned} 13^2 &= 13 \times 13 \\ &= 169 \end{aligned}$$

Example 2: Find the perfect square of 95

Solution:

The perfect square of 95 is

$$\begin{aligned} (95)^2 &= 95 \times 95 \\ &= 9025 \end{aligned}$$

2.2.2 Establish Patterns for the squares of natural numbers.

We know that $4^2 = 4 \times 4 = 16$

We can also write the square of 4 in a Pattern form as

$$4^2 = 1+2+3+4+3+2+1=16$$

Similarly $5^2 = 1+2+3+4+5+4+3+2+1 = 25$

And $6^2 = 1+2+3+4+5+6+5+4+3+2+1=36$

So, we observed that the square of any natural number can be found with the help of summation of above patterns.

1^2	1	= 1
2^2	1 + 2 + 1	= 4
3^2	1 + 2 + 3 + 2 + 1	= 9
4^2	1 + 2 + 3 + 4 + 3 + 2 + 1	= 16
5^2	1 + 2 + 3 + 4 + 5 + 4 + 3 + 2 + 1	= 25
6^2	1 + 2 + 3 + 4 + 5 + 6 + 5 + 4 + 3 + 2 + 1	= 36
7^2	1 + 2 + 3 + 4 + 5 + 6 + 7 + 6 + 5 + 4 + 3 + 2 + 1	= 49
8^2	1 + 2 + 3 + 4 + 5 + 6 + 7 + 8 + 7 + 6 + 5 + 4 + 3 + 2 + 1	= 64
9^2	1 + 2 + 3 + 4 + 5 + 6 + 7 + 8 + 9 + 8 + 7 + 6 + 5 + 4 + 3 + 2 + 1	= 81
10^2	1 + 2 + 3 + 4 + 5 + 6 + 7 + 8 + 9 + 10 + 9 + 8 + 7 + 6 + 5 + 4 + 3 + 2 + 1	= 100

In the above pattern we notice that:

- (i) Each row starts and ends by digit 1.
- (ii) The digits increase upto the number whose square is required and then decrease.
- (iii) The number of digits in each row increases by two digits.
- (iv) The difference of any two consecutive squares is an odd number.
- (v) The number of digits in a particular row is the addition of the number and the previous consecutive numbers whose squares are to be found.

Consider another pattern of squares of natural numbers.

$$\begin{array}{rcl}
 1^2 & = & 1 \\
 2^2 & = & 1+3 \\
 3^2 & = & 1+3+5 \\
 4^2 & = & 1+3+5+7 \\
 5^2 & = & 1+3+5+7+9 \\
 6^2 & = & 1+3+5+7+9+11 \\
 7^2 & = & 1+3+5+7+9+11+13 \\
 8^2 & = & 1+3+5+7+9+11+13+15 \\
 9^2 & = & 1+3+5+7+9+11+13+15+17 \\
 10^2 & = & 1+3+5+7+9+11+13+15+17+19
 \end{array}$$

We observed the pattern and note that:

- (i) The summation is an ascending order.
- (ii) The square of each number is written as the sum of odd numbers only.
- (iii) Each row of the pattern starts from an odd number 1.
- (iv) The number of odd numbers in each row is equal to the number whose square is to be found.
- (v) The sum of each row is equal to the required square.
- (vi) The last odd number in each row is one less than the double of the given number.

EXERCISE 2.2

1. Find the square of the following numbers.

(i) 7	(ii) 11	(iii) 19
(iv) 25	(v) 37	(vi) 75
2. Write the summation patterns for the following squares.

(i) 6^2	(ii) 7^2	(iii) 4^2
(iv) 5^2	(v) 3^2	(vi) 8^2

2.3 SQUARE ROOT

2.3.1 Finding the square root of (a) a natural number (b) a common fraction (c) a decimal given in perfect square form, by prime factorization and division method

The square root of a positive number is that positive number whose square is the given number. The symbol used for square root is $\sqrt{\quad}$.

(a) Finding square root of a natural number.

• By Prime Factorization Method

First of all find prime factors, then make pairs of these factors. Choose one prime number from each pair and then find the product of all those prime factors, which will be the square root of the given number.

Example 1: Find the square root of 225

Solution:

$$\begin{array}{r} 3 \overline{) 225} \\ \underline{3 75} \\ 5 25 \\ \underline{5 5} \\ 1 \end{array}$$

Example 2: Find the square roots of 576

Solution:

$$\begin{array}{r} 2 \overline{) 576} \\ \underline{2 88} \\ 2 144 \\ \underline{2 72} \\ 2 36 \\ \underline{2 18} \\ 3 9 \\ \underline{3 3} \\ 1 \end{array}$$

Example 3: Find the square roots of 1600

Solution:

$$\begin{array}{r} 2 \overline{) 1600} \\ \underline{2 800} \\ 2 400 \\ \underline{2 200} \\ 2 100 \\ \underline{2 50} \\ 5 25 \\ \underline{5 5} \\ 1 \end{array}$$

- **By Division Method:**

To find the square root of natural numbers by division method, we will proceed as under:

- (i) Make pairs of digits from right to left. If the number of digits is even, we have complete pairs. If the number of digits is odd, the last digit on extreme left will remain single.
- (ii) Look for the numbers whose square is equal to or less than the number of extreme left, which may be a single digit or a pair. This number will be divisor as well as quotient.

- (iii) Subtract the product. Bring down the next pair to the right of the remainder.
- (iv) Double the quotient and write as divisor as ten's digit.
- (v) Look for the number whose square will be equal to or less than the dividend. Write that number with the right side of the quotient as well as with divisor at unit place

Example 4: Find the square root of 625

Solution:

$$\begin{array}{r}
 25 \\
 2 \overline{) 625} \\
 \underline{4} \\
 225 \\
 \underline{225} \\
 0
 \end{array}$$

Example 5: Find the square root of 1024

Solution:

$$\begin{array}{r}
 32 \\
 3 \overline{) 1024} \\
 \underline{9} \\
 124 \\
 \underline{124} \\
 0
 \end{array}$$

Example 6: Find the square root of 15129

Solution:

$$\begin{array}{r}
 123 \\
 1 \overline{) 15129} \\
 \underline{1} \\
 51 \\
 \underline{44} \\
 729 \\
 \underline{729} \\
 0
 \end{array}$$

EXERCISE 2.3

- Find the square root of the following by prime factorization method.

(i) 784	(ii) 1225	(iii) 2809	(iv) 4225	(v) 5184
(vi) 7744	(vii) 1296	(viii) 1764	(ix) 29241	
- Find the square root of the following by division method.

(i) 13689	(ii) 29241	(iii) 103041
(iv) 418609	(v) 49729	(vi) 55696
(vii) 240100	(viii) 10329796	

(b) Finding square root of a common fraction

We know that in fraction $\frac{4}{9}$, 4 is numerator and 9 is denominator.

The square root of a fraction is equal to the square root of the numerator divided by the square root of the denominator.

This is illustrated with the help of following examples.

- By Prime Factorization:**

Example 7: Find the square root of $\frac{9}{16}$

Solution:

$$\begin{aligned}\frac{9}{16} &= \frac{3 \times 3}{2 \times 2 \times 2 \times 2} \\ \sqrt{\frac{9}{16}} &= \frac{\sqrt{9}}{\sqrt{16}} \\ &= \frac{\sqrt{3 \times 3}}{\sqrt{2 \times 2 \times 2 \times 2}} = \frac{3}{4}\end{aligned}$$

Example 8: Find the square root of number $1\frac{11}{25}$

Solution:

$$\begin{aligned}1\frac{11}{25} &= \frac{36}{25} = \frac{2 \times 2 \times 3 \times 3}{5 \times 5} \\ \sqrt{1\frac{11}{25}} &= \sqrt{\frac{36}{25}} = \frac{\sqrt{36}}{\sqrt{25}} \\ &= \frac{\sqrt{2 \times 2 \times 3 \times 3}}{\sqrt{5 \times 5}} = \frac{2 \times 3}{5} \\ &= \frac{6}{5} = 1\frac{1}{5}\end{aligned}$$

• **By Division Method:**

We know that the square root of a common fraction is equal to the square root of its numerator divided by the square root of its denominator.

Example 9: Find the square root of number $\frac{169}{289}$

Solution:

$$\begin{array}{r} 13 \\ 1 \overline{) 169} \\ \underline{1} \\ 69 \\ \underline{69} \\ 0 \end{array} \qquad \begin{array}{r} 17 \\ 1 \overline{) 289} \\ \underline{1} \\ 189 \\ \underline{189} \\ 0 \end{array}$$

Example 10: Find the square root of $9\frac{67}{121}$

Solution:

$$\begin{array}{r} 34 \\ 3 \overline{) 1156} \\ \underline{9} \\ 256 \\ \underline{256} \\ 0 \end{array} \qquad \begin{array}{r} 11 \\ 1 \overline{) 121} \\ \underline{1} \\ 21 \\ \underline{21} \\ 0 \end{array}$$

EXERCISE 2.4

1. Find the square root of the following fractions by prime factorization.

- | | | |
|-----------------------|------------------------|-------------------------|
| (i) $\frac{49}{64}$ | (ii) $\frac{121}{625}$ | (iii) $\frac{196}{441}$ |
| (iv) $1\frac{13}{36}$ | (v) $\frac{676}{729}$ | (vi) $12\frac{24}{25}$ |

2. Find the square root of the following fractions by division method.

$$(i) \frac{144}{225} \quad (ii) \frac{169}{256} \quad (iii) \frac{784}{841}$$

$$(iv) \frac{1024}{1225} \quad (v) 5\frac{41}{64}$$

(c) Finding square root of a decimal

• **By Prime Factorization**

We convert the decimal to common fraction and then find square root.

Example 11: Find the square root of decimal 0.64

Solution:

$$\begin{aligned} 0.64 &= \frac{64}{100} \\ \sqrt{\frac{64}{100}} &= \frac{\sqrt{64}}{\sqrt{100}} \\ &= \frac{\sqrt{2 \times 2 \times 2 \times 2 \times 2 \times 2}}{\sqrt{2 \times 2 \times 5 \times 5}} \\ &= \frac{\sqrt{2 \times 2 \times 2 \times 2 \times 2 \times 2}}{\sqrt{2 \times 2 \times 5 \times 5}} \\ &= \frac{2 \times 2 \times 2}{2 \times 5} = \frac{8}{10} \\ &= 0.8 \end{aligned}$$

Example 12: Find the square root of decimal 2.25

Solution:

• **By Division Method:**

For using this method the following steps will be taken.

- (i) Make pairs of digits on the left side of the decimal point from right to left.
- (ii) Make pairs of digits on the right side of the decimal point from left to right.
- (iii) Place the decimal point in the quotient while bringing down the pair after the decimal point.
- (iv) While bringing down two pairs at a time, place a zero in the quotient.

This method is illustrated with the following examples.

Example 13: Find the square root of 180.9025

Solution:

$$\begin{array}{r}
 13.45 \\
 \hline
 1 \quad 180.9025 \\
 \underline{1} \quad \downarrow \quad \downarrow \quad \downarrow \\
 23 \quad 80 \quad \downarrow \quad \downarrow \\
 \underline{69} \quad \downarrow \quad \downarrow \\
 264 \quad 1190 \quad \downarrow \\
 \underline{1056} \quad \downarrow \\
 2685 \quad 13425 \\
 \underline{13425} \\
 0
 \end{array}$$

$1 \times 21 = 21$
$2 \times 22 = 44$
$3 \times 23 = 69$
$4 \times 24 = 96$

$1 \times 261 = 261$
$2 \times 262 = 524$
$3 \times 263 = 789$
$4 \times 264 = 1056$
$5 \times 265 = 1325$

$1 \times 2681 = 2681$
$2 \times 2682 = 5364$
$3 \times 2683 = 8049$
$4 \times 2684 = 10736$
$5 \times 2685 = 13425$

Example 14: Find the square root of 0.053361

Solution:

$$\begin{array}{r}
 0.231 \\
 \hline
 2 \quad 0.053361 \\
 \underline{04} \quad \downarrow \quad \downarrow \\
 43 \quad 133 \quad \downarrow \\
 \underline{129} \quad \downarrow \\
 461 \quad 461 \\
 \underline{461} \\
 0
 \end{array}$$

Example 15: Find the square root of decimal 152.7696

Solution:

$$\begin{array}{r}
 12.36 \\
 \hline
 1 \quad \overline{152.7696} \\
 \underline{1} \quad \downarrow \quad | \quad | \\
 22 \quad 52 \quad \downarrow \quad | \quad | \\
 \quad \quad 44 \quad \downarrow \quad | \quad | \\
 243 \quad 876 \quad \downarrow \quad | \quad | \\
 \quad \quad \quad 729 \quad \downarrow \quad | \quad | \\
 2466 \quad 14796 \\
 \underline{14796} \\
 0
 \end{array}$$

EXERCISE 2.5

1. Find the square root of the following decimals by prime factorization.

- (i) 1.21 (ii) 0.64 (iii) 7.29
- (iv) 1.44 (v) 1.69 (vi) 12.25

2. Find the square root of the following decimals by division method.

- (i) 0.3249 (ii) 0.5184 (iii) 10.24
- (iv) 20.5209 (v) 648.7209 (vi) 2981.16
- (vii) 7613.609536 (viii) 0.00868624 (ix) 2374.6129

2.3.2 Find square root of a number which is not a perfect square.

Example 16: Find the square root of 2 upto 3 decimal places.

Solution:

$$\begin{array}{r}
 1.414 \\
 \hline
 1 \quad \overline{2.000000} \\
 \underline{1} \quad \downarrow \quad | \quad | \\
 24 \quad 100 \quad \downarrow \quad | \quad | \\
 \quad \quad 96 \quad \downarrow \quad | \quad | \\
 281 \quad 400 \quad \downarrow \quad | \quad | \\
 \quad \quad \quad 281 \quad \downarrow \quad | \quad | \\
 2824 \quad 11900 \\
 \underline{11296} \\
 \quad \quad \quad 604 \\
 \quad \quad \quad \dots\dots\dots \\
 \quad \quad \quad \dots\dots\dots
 \end{array}$$

$\therefore \sqrt{2} = 1.414 \dots$

We observe that:

The process is non-terminating, so we cannot get zero as remainder.

In the quotient after the decimal point there is no group of integers which is repeating itself as in the case of rational numbers.

$$\frac{2}{3} = 0.666 \quad \text{and} \quad \frac{7}{9} = 0.777$$

Remember that:

If we cannot find the number whose square is x , then \sqrt{x} is an irrational number.

Example 17: Find the square root of 2.5 upto two decimal places.

Solution:

$$\begin{array}{r}
 1.58 \\
 1 \overline{) 2.5000} \\
 \underline{1} \\
 150 \\
 \underline{125} \\
 2500 \\
 \underline{2464} \\
 3600 \\
 \dots\dots\dots \\
 \dots\dots\dots
 \end{array}$$

$$\therefore \sqrt{2.5} \cong 1.58$$

In such case we restrict the process after some decimal places. Here we shall restrict it upto 2 decimal places.

Example 18: Find the square root of 0.257960 upto three decimal places.

Solution:

$$\begin{array}{r}
 0.507 \\
 5 \overline{) 0.257960} \\
 \underline{25} \\
 7960 \\
 \underline{7049} \\
 911 \\
 \dots\dots\dots \\
 \dots\dots\dots
 \end{array}$$

$$\therefore \sqrt{0.257960} \cong 0.507 \dots$$

EXERCISE 2.6

1. Find the square root of the following upto three decimal places.

(i) 2

(ii) 3

(iii) 5

(iv) 7

(v) 11

(vi) 15

2. Find the square root of the following upto two decimal places

(i) 3.6

(ii) 6.4

(iii) 28.9

(iv) 63.34

(v) 816.081

(vi) 36.008

2.3.3 Use the Rule to Determine the Number of Digits in the Square Root of a Perfect Square

Rule: Let n be the number of digits in the perfect square then its square root contains:

(i) $\frac{n}{2}$ digits if n is even

(ii) $\frac{n+1}{2}$ digits if n is odd

Now we apply the above rule for finding the number of digits in the square root of a perfect square with the help of following examples:

Example 19: Find the number of digits in the square root of 49729

Solution:

Number of digits of the given number = 5

$n = 5$ is odd, so mentioned above rule (ii) will be applied

\therefore Thus the number of digits in the square root will be $= \frac{n+1}{2} = \frac{5+1}{2} = \frac{6}{2} = 3$

\therefore To check the answer, we proceed as under

$$\begin{array}{r}
 223 \\
 \hline
 2 \overline{) 49729} \\
 \underline{4} \\
 97 \\
 \underline{84} \\
 1329 \\
 \underline{1329} \\
 0
 \end{array}$$

\therefore

The square root 223 has 3 digits

Example 20: Find the number of digits in the square root of 10329796

Solution:

Number of digits (n) = 8

Now $n = 8$ is even, so part (i) of the rule will be applied $\frac{n}{2}$

\therefore The number of digits in the square root = $\frac{n}{2} = \frac{8}{2} = 4$

Now, we can verify it

$$\begin{array}{r}
 3214 \\
 3 \overline{) 10329796} \\
 \underline{9 } \\
 132 \\
 \underline{124 } \\
 897 \\
 \underline{641 } \\
 25696 \\
 \underline{25696} \\
 0
 \end{array}$$

\therefore

The square root 3214 has 4 digits

EXERCISE 2.7

1. Find the number of digits in the square root of the following perfect square

- | | | |
|---------------|----------------|----------------|
| (i) 63504 | (ii) 66564 | (iii) 50625 |
| (iv) 837225 | (v) 839056 | (vi) 1054729 |
| (vii) 1577536 | (viii) 2119936 | (ix) 3283344 |
| (x) 614656 | (xi) 7778521 | (xii) 12880921 |

2.3.4 Real Life Problems Involving Square Roots

Example 21: 1225 students stand in rows in such a way that the number of rows is equal to the number of students in a row. How many students are there in each row?

Solution: Since the number of students in a row is the same as the number of rows, square root of 1225 will be found.

$$\begin{array}{r}
 35 \\
 3 \overline{) 1225} \\
 \underline{9 } \\
 325 \\
 \underline{325} \\
 0
 \end{array}$$

Thus, the number of students in each row = 35

Example 22: A rectangular field has an area of 18432 square metres. Its width is half as long as its length. Find its perimeter.

Solution: Since the width of the field is half as long as its length, this rectangle can be divided into two square regions.

$$\therefore \text{The area of each square region} = \frac{18432}{2} = 9216 \text{ m}^2$$

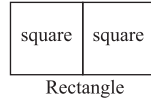

To find the length of its side, we will find the square root of 9216.

$$\begin{array}{r} 96 \\ 9 \overline{) 9216} \\ \underline{81} \downarrow \\ 1116 \\ \underline{1116} \\ 0 \end{array}$$

\therefore The width of each side 96 metres.

So the length of the rectangle = $96 \times 2 = 192$ metres.

Thus the perimeter = $2(192 + 96) = 2(288) = 576$ metres.

Example 23: Find the least number which, when subtracted from 58780, the answer is a complete square.

Solution: To find which number is subtracted from the given number, we find the square root of 58780 and the remainder will be the required number.

$$\begin{array}{r} 242 \\ 2 \overline{) 58780} \\ \underline{4} \downarrow \\ 187 \downarrow \\ \underline{176} \downarrow \\ 1180 \\ \underline{964} \\ 216 \end{array}$$

Remaining Number = Given number – Remainder = $58780 - 216 = 58564$

Thus, if 216 is subtracted from 58780, the remaining number 58564 will be a complete square.

EXERCISE 2.8

- The area of a square field is 14400 sq. metre. Find the length of the side of the square.
- The area of a square field is 422500 sq. metre. How much string is required for fixing along the sides as a fence?

3. A gardener wants to plant 122500 trees in his field in such a way that the number of trees in a row is equal to the number of rows. How many trees will he plant in each row?
4. The area of a rectangular field is 10092 *sq.* metre. Its length is three times as long as its width. Find its perimeter.
5. The area of a circular region is 616 *sq.* decimetre. Find its radius.
6. A rectangular field has an area 28800 *sq.* metre. Its length is twice as long as its width. What is the length of its sides?
7. Find that least number which, when subtracted from 109087, the answer is a complete square.
8. The cost of levelling the ground of a circular region at a rate of *Rs.*2 per square metre is *Rs.*4928. Find the radius of the ground.
9. The cost of ploughing in a square field is *Rs.*2450 at the rate of *Rs.*2 per 100 *sq.* metres. Find the length of the side of the square.
10. A square lawn area is 62500 *sq.* metre. A wooden fence is to be laid around the lawn. How long wooden fence is required? What will be its cost at the rate of *Rs.*50 per metre?

2.4 CUBES AND CUBE ROOTS

2.4.1 Recognition of cubes and perfect cubes

- **Cubes**

Cube of a number means to multiply the number by itself three times.

Let x be any number

then, $x \times x \times x = x^3$

For example

$$2 \times 2 \times 2 = 2^3$$

$$3 \times 3 \times 3 = 3^3$$

$$4 \times 4 \times 4 = 4^3 \quad \text{and so on}$$

- **Perfect cubes**

Perfect cube is a number that is the result of multiplying an integer by itself three times. In other words it is an integer to the third power of another integer.

Example 1: Show that 8, 27 and 216 are perfect cubes.

Solution:

$$8 = 2 \times 2 \times 2 = 2^3$$

8 is a perfect cube of 2

$$27 = 3 \times 3 \times 3 = 3^3$$

27 is a perfect cube of 3

$$216 = 2 \times 2 \times 2 \times 3 \times 3 \times 3$$

$$= 2^3 \times 3^3$$

$$= (2 \times 3)^3 = 6^3 \quad \therefore \quad 216 \text{ is a perfect cube of } 6$$

Example 2: Find cube of 1.2

Solution: $(1.2)^3 = (1.2) \times (1.2) \times (1.2)$
 $= (1.44) \times (1.2)$
 $= 1.728$

2.4.2 Finding cube Roots of numbers which are perfect cubes

In mathematics a cube root of a number, denoted by $x^{1/3}$, is a number such that $a^3 = x$. i.e. $a = x^{1/3}$

Symbol of cube root is $\sqrt[3]{\quad}$, Remember that 3 is a part of the symbol

Example 3: Find the cube root of 125

Solution: $125 = 5 \times 5 \times 5 = 5^3$
 $=$
 $= (5^3)^{1/3}$
 $= 5$

$$\begin{array}{r|l} 5 & 125 \\ \hline 5 & 25 \\ \hline 5 & 5 \\ \hline & 1 \end{array}$$

Example 4: Find the cube root of 9261

Solution:

$9261 = 3 \times 3 \times 3 \times 7 \times 7 \times 7$
 $= 3^3 \times 7^3$
 $\therefore \sqrt[3]{9261} = \sqrt[3]{3^3 \times 7^3}$
 $= (3^3 \times 7^3)^{1/3}$
 $= (3^3)^{1/3} \times (7^3)^{1/3}$
 $= 3 \times 7$
 $= 21$

$$\begin{array}{r|l} 3 & 9261 \\ \hline 3 & 3087 \\ \hline 3 & 1029 \\ \hline 7 & 343 \\ \hline 7 & 49 \\ \hline 7 & 7 \\ \hline & 1 \end{array}$$

2.4.3 Recognition of Properties of Cubes of numbers

- (i) Cube of a positive number is + ve. e.g., $3^3 = 27$
- (ii) Cube of a (negative) number is negative.
e.g., $(-4)^3 = -64$
- (iii) Cube of an even number is even. e.g., $6^3 = 216$
- (iv) Cube of an odd number is odd. e.g., $7^3 = 343$
- (v) Cube of distributive properties under (a) multiplication and (b) division

(a) $(5 \times 7)^3 = 5^3 \times 7^3$

(b) $\left(\frac{5}{7}\right)^3 = \frac{5^3}{7^3}$

(vi) Cube number of the perfect cubes

$6^3 = 216$, $4^3 = 64$, $8^3 = 512$

So, 216, 64 and 512 are perfect cubes.

EXERCISE 2.9

1. Which are the perfect cubes?

(i) 512	(ii) 1100	(iii) 6859
(iv) 729	(v) $\frac{1000}{125}$	
2. Find the cube roots of the following:

(i) 729	(ii) 15625	(iii) 13824
---------	------------	-------------
3. Find the cubes of the following:

(i) 1.4	(ii) 0.4	(iii) 0.8
---------	----------	-----------
4. Find the cube roots of the following:

(i)	(ii)	(iii)
-----	------	-------

REVIEW EXERCISE 2

1. Four options are given against each statement. Encircle the correct one.
 - i. Real number is:
 - (a) difference of rational numbers and irrational numbers
 - (b) intersection of rational numbers and irrational numbers
 - (c) union of rational numbers and irrational numbers
 - (d) complement of set of natural numbers
 - ii. Which of the following is not true about ?

(a) natural number	(b) whole number
(c) rational number	(d) irrational number
 - iii. Which one of the following is perfect square?

(a) 25.6	(b) .256	(c) 2.56	(d) 2560
----------	----------	----------	----------
 - iv. Square of 0.9 is:

(a) 0.81	(b) 8.10	(c) 0.081	(d) 81.0
----------	----------	-----------	----------
 - v. = ?

(a)	(b)	(c)	(d)
-----	-----	-----	-----
 - vi. $1 + 2 + 3 + 4 + 5 + 6 + 7 + 8 + 7 + 6 + 5 + 4 + 3 + 2 + 1 = ?$

(a) 8^2	(b) 9^2	(c) 65	(d) 81
-----------	-----------	--------	--------

vii. If the side length of a square is $0.5m$ then its area is:

- (a) $0.50m^2$ (b) $2.5m^2$ (c) $.25m^2$ (d) $25m^2$

viii. ?

- (a) .02 (b) 2.0 (c) 0.2 (d) 20

ix. ?

- (a) 4 (b) 14 (c) 41 (d) 2

x. ?

- (a) 3 (b) 4 (c) 5 (d) 6

xi. = ?

- (a) $\frac{2}{3}$ (b) $\frac{2}{9}$ (c) $\frac{4}{3}$ (d) $\frac{3}{2}$

xii. = ?

- (a) $\frac{a}{b}$ (b) ab (c) (d)

2. Find the number of digits in the square root of the following numbers. Also find the square root.

- (a) 418609 (b) 30349081 (c) 12544

3. Find the square root of the following:

- (a) $28\frac{4}{9}$ (b) $17\frac{128}{289}$ (c) $101\frac{92}{169}$
 (d) 0.053361 (e) 0.204304 (f) 152.7696
 (g) 0.25694 (h) 38.01 (i) 64.31

4. If the area of a square field is $161604 m^2$. Find the length of its one side.

5. Saeeda has 196 marbles that she is using to make a square formation. How many marbles should be in each row?

6. Find the cube root of the following numbers.

- (a) 1728 (b) 3375 (c) $\frac{216}{125}$

SUMMARY

- The number which cannot be written in the form of $\frac{p}{q}$ where $p, q \in Z$ and $q \neq 0$ is called irrational number.
- Set of Real Numbers is the union of Rational and Irrational Numbers i.e.,
 $R = Q \cup Q'$
- A number whose decimal representation is non-terminating and recurring is called an rational number.
- The decimal fraction in which the digits after the decimal point are finite, is called terminating decimal fraction.
- The decimal fraction, in which the digits after the decimal point are infinite, is called non-terminating.
- The product of a number by itself is known as square.
- The square root of a positive number is that positive number whose square is the given number.
- Cube of a number means to multiply the number by itself three times.

Unit - 3



Number Systems

After completion of this unit, the students will be able to:

- Recognize base of a number system.
- Define number system with base 2, 5, 8 and 10
- Explain
 - Binary number system (system with base 2),
 - Number system with base 5,
 - Octal number system (system with base 8),
 - Decimal number system (system with base 10).
- Convert a number from decimal system to a system with base 2, 5 and 8, and vice versa.
- Add, subtract and multiply numbers with base 2, 5 and 8.
- Add, subtract and multiply numbers with different bases.

3.1 NUMBER SYSTEMS

Any number can be formed with the help of 10 digits

i.e., 0, 1, 2, 3, 4, 5, 6, 7, 8 and 9.

These numbers are called numerals and these numerals are known as 'Arabic numerals'.

3.1.1 Base of a Number System:

The number of digits involved in a number system is called the base of that number system. If a number system involves only two digits 0, 1, then base is 2. A number system, in which 10 digits 0, 1, 2, 3, 4, 5, 6, 7, 8 and 9 are used, is a system with base 10.

Similarly, a number system in which five digits 0, 1, 2, 3 and 4 are used is a system with base 5.

3.1.2 To Define Number System with Base 2, 5, 8 and 10:

(a) Number System with Base 2:

A number system formed by two digits 0, 1 is called **Binary system** and its base is 2. This system is not used in everyday life apparently. But it is very important number system because it is used in all types of computers. Because computer stores information in the form of binary numbers so the binary system is of primary importance in the modern age of computer.

(b) Number System with Base 5:

This number system involves digits 0, 1, 2, 3 and 4. The largest digit in base 5 system is 4.

(c) Number System with Base 8:

The number system with base 8 is called octal system. In this system eight digits 0, 1, 2, 3, 4, 5, 6 and 7 are used. The largest digit in base 8 system is 7.

(d) Decimal Number System:

Decimal number system is the most popular number system in the world. In this system, ten digits (0 to 9) are used. Every number can be expressed as the sum of multiples of powers of 10 and 10 is called its base.

3.2 CONVERSIONS:

The above discussed number systems are all place value number systems. The numbers used in these systems can be converted from one system to another system. The method of successive division is used to convert a number from one system to another system. The division is performed by the base of the system in which it is being converted.

3.2.1(a) Conversion from Decimal Number System to Other Number Systems:

(i) Conversion from Decimal to Binary System:

Example 1: Convert 15 into an equivalent number with base 2

Solution:

$$\begin{array}{r|l}
 2 & 15 \\
 \hline
 2 & 7 - 1 \uparrow \\
 \hline
 2 & 3 - 1 \\
 \hline
 & 1 - 1 \rightarrow
 \end{array}
 \quad 15 = (1111)_2$$

The number $(1111)_2$ will be read as one, one, one, one base 2

Example 2: Convert 541 into binary system.

Solution:

$$\begin{array}{r|l}
 2 & 541 \\
 \hline
 2 & 270 - 1 \uparrow \\
 \hline
 2 & 135 - 0 \\
 \hline
 2 & 67 - 1 \\
 \hline
 2 & 33 - 1 \\
 \hline
 2 & 16 - 1 \\
 \hline
 2 & 8 - 0 \\
 \hline
 2 & 4 - 0 \\
 \hline
 2 & 2 - 0 \\
 \hline
 & 1 - 0 \rightarrow
 \end{array}$$

Thus, $541 = (1000011101)_2$

(ii) Conversion from Decimal System to a Number with Base 5:

Any number of decimal system can be converted into an equivalent number with base 5 as follows.

Example 3: Convert 17 into an equivalent number with base 5

Solution:

$$\begin{array}{r|l}
 5 & 17 \\
 \hline
 & 3 - 2 \rightarrow
 \end{array}$$

Thus, $17 = (32)_5$

Example 4: Convert 89651 into an equivalent number with base 5

Solution:

5	89651	
5	17930	- 1
5	3586	- 0
5	717	- 1
5	143	- 2
5	28	- 3
5	5	- 3
	1	- 0

Thus, $89651 = (10332101)_5$

(iii) Conversion from Decimal to Octal System (Base 8)

Example 5: Convert 824 into an equivalent number with base 8

Solution:

8	824	
8	103	- 0
8	12	- 7
	1	- 4

Hence, $824 = (1470)_8$

Example 6: Convert 4837 into an equivalent number with base 8

Solution:

8	4837	
8	604	- 5
8	75	- 4
8	9	- 3
8	1	- 1

Hence, $4837 = (11345)_8$

3.2.1(b) Conversion from other Number Systems to Decimal Number System:

(i) Conversion from Binary System to Decimal System:

For converting a number written in binary system into a number in decimal system, consider the following example.

Example 7: Convert $(1101)_2$ into equivalent number in decimal system.

Solution: $(1101)_2 = 1 \times 2^3 + 1 \times 2^2 + 0 \times 2^1 + 1 \times 2^0$
 $= 8 + 4 + 0 + 1 = 13$

(ii) Converting a Number written in Base 5 System into Decimal System:

Any number in base 5 system can be converted into base 10 system.

For converting a number in base 5 into an equivalent number with base 10, consider the following example.

Example 8: Convert $(413242)_5$ into equivalent decimal system.

Solution: $(413242)_5 = 4 \times 5^5 + 1 \times 5^4 + 3 \times 5^3 + 2 \times 5^2 + 4 \times 5^1 + 2 \times 5^0$
 $= 4 \times 3125 + 1 \times 625 + 3 \times 125 + 2 \times 25 + 4 \times 5 + 2 \times 1$
 $= 12500 + 625 + 375 + 50 + 20 + 2$
 $= 13572$

(iii) Conversion from Octal System to Decimal System:

Consider the following examples.

Example 9: Write the following octal numbers as decimal numbers.

(i) $(126)_8$ **(ii)** $(424002)_8$

Solution: **(i)** $(126)_8$

$$(126)_8 = 1 \times 8^2 + 2 \times 8^1 + 6 \times 8^0$$

$$= 1 \times 64 + 2 \times 8 + 6 \times 1$$

$$= 64 + 16 + 6 = 86$$

(ii) $(424002)_8$

$$(424002)_8 = 4 \times 8^5 + 2 \times 8^4 + 4 \times 8^3 + 0 \times 8^2 + 0 \times 8^1 + 2 \times 8^0$$

$$= 4 \times 32768 + 2 \times 4096 + 4 \times 512 + 0 + 0 + 2 \times 1$$

$$= 131072 + 8192 + 2048 + 0 + 0 + 2$$

$$= 141314$$

EXERCISE 3.1

1. Convert the following into decimal system.

(i) $(101)_2$

(ii) $(2044)_5$

(iii) $(1101110)_2$

(iv) $(7016)_8$

(v) $(2360)_8$

(vi) $(1011010100)_2$

(vii) $(1001001)_2$

(viii) $(3100)_5$

2. Convert the following into the base system as indicated against each question.
- (i) 3025 to binary, octal and base 5 (ii) $(671)_8$ to binary and base 5
 (iii) $(2006)_8$ to binary and base 5 (iv) 867 to binary, octal and base 5
 (v) $(10011001)_2$ to octal and base 5

3.2.2 Adding, Subtracting and Multiplying Numbers with Base 2:

(a) Binary Number System (Base 2):

Addition: We know that in the binary number system only two digits 0 and 1 are used.

While adding, if the sum is greater than 1 then, divide the sum by 2, write the remainder and carry quotient to the next digit.

The following addition table is helpful in finding the sums in the number system with base 2.

Addition Table for Binary System

+	0	1
0	0	1
1	1	(10)

Example 10: Find the sum of $(111)_2$ and $(10)_2$.

Solution: We have $(111)_2 + (10)_2 = (1001)_2$ in the horizontal form.

In the vertical form, we write

$$\begin{array}{r} (111)_2 \\ + (10)_2 \\ \hline (1001)_2 \end{array}$$

In the second column $1 + 1 = 2$ and so we carry 1 to the third column and in binary system 2 is written as $(10)_2$.

Example 11: Solve: $(10110111)_2 + (100011)_2$

Solution: $(10110111)_2 + (100011)_2 = (11011010)_2$ in the horizontal form.

In the vertical form, we write

$$\begin{array}{r} (10110111)_2 \\ + (100011)_2 \\ \hline (11011010)_2 \end{array}$$

Subtraction:**Example 12:** Find: $(101)_2 - (11)_2$ **Solution:**

$$\begin{array}{r}
 \textcircled{2} \\
 (101)_2 \\
 - (11)_2 \\
 \hline
 (10)_2
 \end{array}$$

In decimal system we borrow one "10" from the next column for subtracting a greater number from smaller number. Similarly, in binary system we borrow one "2" from the next column. In the 2nd column 1 cannot be subtracted from 0, so we borrow 1 from third column.

Example 13: Subtract $(1101)_2$ from $(10011)_2$ **Solution:**

$$\begin{array}{r}
 \textcircled{1} \\
 \textcircled{0} \textcircled{2} \textcircled{2} \\
 (10011)_2 \\
 - (1101)_2 \\
 \hline
 (110)_2
 \end{array}$$

Multiplication:

The numbers having base 2, we use the following multiplication table.

Multiplication Table (Base 2)

×	0	1
0	0	0
1	0	1

Example 14: Multiply $(11)_2$ by $(10)_2$ **Solution:**

$$\begin{array}{r}
 (11)_2 \\
 \times (10)_2 \\
 \hline
 (00)_2 \\
 (110)_2 \\
 \hline
 (110)_2
 \end{array}$$

Example 15: Solve: $(11011011)_2 \times (10101)_2$

Solution:

$$\begin{array}{r}
 (1\ 1\ 0\ 1\ 1\ 0\ 1\ 1)_2 \\
 \times (1\ 0\ 1\ 0\ 1)_2 \\
 \hline
 1\ 1\ 0\ 1\ 1\ 0\ 1\ 1 \\
 0\ 0\ 0\ 0\ 0\ 0\ 0\ 0\ 0 \\
 1\ 1\ 0\ 1\ 1\ 0\ 1\ 1\ 0\ 0 \\
 0\ 0\ 0\ 0\ 0\ 0\ 0\ 0\ 0\ 0\ 0 \\
 1\ 1\ 0\ 1\ 1\ 0\ 1\ 1\ 0\ 0\ 0\ 0 \\
 \hline
 (1\ 0\ 0\ 0\ 1\ 1\ 1\ 1\ 1\ 0\ 1\ 1\ 1)_2
 \end{array}$$

(b) Base 5 Number System:

Addition:

While adding, if the sum of two or more digits is greater than 5, divide the sum by 5, write the remainder and carry the quotient to the next digit.

The following addition table will be helpful in finding the sums in the number system with base 5.

Addition Table for base 5

+	0	1	2	3	4
0	0	1	2	3	4
1	1	2	3	4	10
2	2	3	4	10	11
3	3	4	10	11	12
4	4	10	11	12	13

The process of addition is explained by the following examples.

Example 16: Solve: $(4)_5 + (3)_5$

Solution:

$4 + 3 = 7$ and in the system with base 5, 7 is represented by $(12)_5$

So, $(4)_5 + (3)_5 = (12)_5$.

Example 17: Find the sum of $(12433)_5$ and $(31243)_5$

Solution:

$$\begin{array}{r}
 \textcircled{1}\ \textcircled{1}\ \textcircled{1} \\
 (1\ 2\ 4\ 3\ 3)_5 \\
 + (3\ 1\ 2\ 4\ 3)_5 \\
 \hline
 (4\ 4\ 2\ 3\ 1)_5
 \end{array}$$

Subtraction:

Example 18: Find: $(3421)_5 - (2143)_5$

Solution:

$$\begin{array}{r}
 \textcircled{5} \\
 \textcircled{3} \textcircled{1} \textcircled{5} \\
 (3 \ 4 \ 2 \ 1)_5 \\
 - (2 \ 1 \ 4 \ 3)_5 \\
 \hline
 (1 \ 2 \ 2 \ 3)_5
 \end{array}$$

To subtract 3 from 1 is not possible so borrow a “5” from the second column and add it to the 1st column i.e., $5 + 1 = 6$ and then subtract 3 from 6.
 In the 2nd column “1” is left behind. Now 4 cannot be subtracted from 1. Again borrow a “5” from the 3rd column and add it to the second column i.e., $5 + 1 = 6$ and $6 - 4 = 2$. After borrowing 1, 3 is left in the 3rd column and so $3 - 1 = 2$.

Multiplication:

For multiplying the number having base 5, the following multiplication table is useful.

Multiplication Table (Base 5)

×	0	1	2	3	4
0	0	0	0	0	0
1	0	1	2	3	4
2	0	2	4	11	13
3	0	3	11	14	22
4	0	4	13	22	31

Example 19: Multiply $(23)_5$ by $(14)_5$

Solution:

$$\begin{array}{r}
 \textcircled{2} \\
 (2 \ 3)_5 \\
 \times (1 \ 4)_5 \\
 \hline
 2 \ 0 \ 2 \\
 2 \ 3 \ 0 \\
 \hline
 (4 \ 3 \ 2)_5
 \end{array}$$

Since $4 \times 3 = 12$, divide 12 by 5, carry the quotient 2 and write down the remainder 2.
 Similarly $4 \times 2 = 8$, add 2 already carried then divide 10 by 5, carry the quotient 2 and write down the remainder 0.

Example 20: Solve: $(421)_5 \times (234)_5$

Solution:

$$\begin{array}{r}
 \textcircled{1} \textcircled{2} \qquad \textcircled{1} \\
 \downarrow \qquad \downarrow \qquad \textcircled{3} \textcircled{1} \\
 \downarrow \qquad \downarrow \qquad \downarrow \\
 \begin{array}{r}
 (4 \ 2 \ 1)_5 \\
 \times (2 \ 3 \ 4)_5 \\
 \hline
 3 \ 2 \ 3 \ 4 \\
 2 \ 3 \ 1 \ 3 \ 0 \\
 1 \ 3 \ 4 \ 2 \ 0 \ 0 \\
 \hline
 (2 \ 2 \ 1 \ 1 \ 1 \ 4)_5
 \end{array}
 \end{array}$$

(c) Octal Number System (Base 8)**Addition:**

In octal number system, we start counting from 0 and proceed to 7. We add one more unit in 7, we get eight which is written as:

$$7 + 1 = (10)_8$$

It is read as, one zero with base 8

Example 21: Add the following octal numbers.

(i) $(6)_8 + (7)_8$ **(ii)** $(64)_8 + (44)_8$ **(iii)** $(255636)_8 + (143576)_8$

Solution:

(i) $(6)_8 + (7)_8$

Write $(6)_8 + (7)_8$ in the vertical form.

$$\begin{array}{r} (6)_8 \\ + (7)_8 \\ \hline (15)_8 \end{array}$$

Thus, $(6)_8 + (7)_8 = (15)_8$

(ii) $(64)_8 + (44)_8$

Write $(64)_8 + (44)_8$ in the vertical form.

$$\begin{array}{r} \textcircled{1} \\ (64)_8 \\ + (44)_8 \\ \hline (130)_8 \end{array}$$

Thus, $(64)_8 + (44)_8 = (130)_8$

(iii) $(255636)_8 + (143576)_8$

Write $(255636)_8 + (143576)_8$ in the vertical form.

$$\begin{array}{r} \textcircled{1} \textcircled{1} \textcircled{1} \textcircled{1} \textcircled{1} \\ (255636)_8 \\ + (143576)_8 \\ \hline (421434)_8 \end{array}$$

Thus, $(255636)_8 + (143576)_8 = (421434)_8$

Subtraction:**Example 22:** Evaluate the following:

(i) $(14)_8 - (6)_8$ (ii) $(604)_8 - (247)_8$ (iii) $(455122)_8 - (216634)_8$

Solution: (i) $(14)_8 - (6)_8$ Write $(14)_8 - (6)_8$ in the vertical form.

$$\begin{array}{r} (14)_8 \\ - (6)_8 \\ \hline (6)_8 \end{array}$$

Thus, $(14)_8 - (6)_8 = (6)_8$

(ii) $(604)_8 - (247)_8$

Write $(604)_8 - (247)_8$ in the vertical form.

$$\begin{array}{r} (604)_8 \\ - (247)_8 \\ \hline (335)_8 \end{array}$$

Thus, $(604)_8 - (247)_8 = (335)_8$

(iii) $(455122)_8 - (216634)_8$

Write $(455122)_8 - (216634)_8$ in the vertical form.

$$\begin{array}{r} (455122)_8 \\ - (216634)_8 \\ \hline (236266)_8 \end{array}$$

Thus, $(455122)_8 - (216634)_8 = (236266)_8$ **Multiplication:****Example 23:** Multiply

(i) $(36)_8 \times (43)_8$

(ii) $(446)_8 \times (213)_8$

Solution:

(i) $(36)_8 \times (43)_8$

Write $(36)_8 \times (43)_8$ in the vertical form.

$$\begin{array}{r} \textcircled{3} \\ \textcircled{2} \\ (36)_8 \\ \times (43)_8 \\ \hline (132)_8 \\ (1700)_8 \\ \hline (2032)_8 \end{array}$$

Thus, $(36)_8 \times (43)_8 = (2032)_8$

(ii) $(446)_8 \times (213)_8$

Write $(446)_8 \times (213)_8$ in the vertical form.

$$\begin{array}{r}
 \textcircled{1}\textcircled{1} \\
 \textcircled{1}\textcircled{2} \\
 (446)_8 \\
 \times (213)_8 \\
 \hline
 (1562)_8 \\
 (4460)_8 \\
 (111400)_8 \\
 \hline
 (117642)_8
 \end{array}$$

Thus, $(446)_8 \times (213)_8 = (117642)_8$

3.2.3 Adding, Subtracting and Multiplying Numbers with Different Bases

As we are familiar in our daily life with decimal number system so, in order to perform arithmetic operations on numbers with different bases (2, 5, 8 or 10), we first convert all the numbers into the decimal system and perform the given operations. Then the answer can be converted into base 2, 5 and 8 as required.

Example 24: Find: $(100111)_2 + (4123)_5 + 567$ and express the answer in all the three number systems. (i.e., in the number system with bases 2, 5 and 10)

Solution: We convert both $(100111)_2$ and $(4123)_5$ into decimal system.

$$\begin{aligned}
 (100111)_2 &= 1 \times 2^5 + 0 \times 2^4 + 0 \times 2^3 + 1 \times 2^2 + 1 \times 2^1 + 1 \times 2^0 \\
 &= 32 + 0 + 0 + 4 + 2 + 1 = 39
 \end{aligned}$$

$$\begin{aligned}
 (4123)_5 &= 4 \times 5^3 + 1 \times 5^2 + 2 \times 5^1 + 3 \times 5^0 \\
 &= 500 + 25 + 10 + 3 = 538
 \end{aligned}$$

$$(10111)_2 + (4123)_5 + 567 = 39 + 538 + 567 = 1144$$

Now, we convert 1144 into the systems with base 2 and base 5.

$$\begin{array}{r|l}
 2 & 1144 \\
 \hline
 2 & 572 - 0 \\
 \hline
 2 & 286 - 0 \\
 \hline
 2 & 143 - 0 \\
 \hline
 2 & 71 - 1 \\
 \hline
 2 & 35 - 1 \\
 \hline
 2 & 17 - 1 \\
 \hline
 2 & 8 - 1 \\
 \hline
 2 & 4 - 0 \\
 \hline
 2 & 2 - 0 \\
 \hline
 & 1 - 0
 \end{array}$$

$$\begin{array}{r|l}
 5 & 1144 \\
 \hline
 5 & 228 - 4 \\
 \hline
 5 & 45 - 3 \\
 \hline
 5 & 9 - 0 \\
 \hline
 & 1 - 4
 \end{array}$$

$$1144 = (14034)_5$$

$$1144 = (10001111000)_2$$

$$(100111)_2 + (4123)_5 + 567 = (10001111000)_2$$

$$(100111)_2 + (4123)_5 + 567 = (14034)_5$$

Example 25: Evaluate: $(777)_8 - (2343)_5 - (1000111)_2$

And express the answer in the number system with base 2

Solution: Convert all the numbers into decimal number system.

$$(777)_8 = 7 \times 8^2 + 7 \times 8^1 + 7 \times 8^0$$

$$= 7 \times 64 + 56 + 7 \times 1$$

$$= 448 + 56 + 7$$

$$= 511$$

$$(2343)_5 = 2 \times 5^3 + 3 \times 5^2 + 4 \times 5^1 + 3 \times 5^0$$

$$= 250 + 75 + 20 + 3$$

$$= 348$$

$$(1000111)_2 = 1 \times 2^6 + 0 \times 2^5 + 0 \times 2^4 + 0 \times 2^3 + 1 \times 2^2 + 1 \times 2^1 + 1 \times 2^0$$

$$= 64 + 4 + 2 + 1 = 71$$

$$(777)_8 - (2343)_5 - (1000111)_2 = 511 - 348 - 71$$

$$= 511 - 419$$

$$= 92$$

Now convert 92 into binary system

2	92	
2	46	- 0
2	23	- 0
2	11	- 1
2	5	- 1
2	2	- 1
1	1	- 0

$$\therefore 92 = (1011100)_2$$

EXERCISE 3.2

1. Solve:

(i) $(101)_2 + (111)_2$

(ii) $(11001000111)_2 + (1010110111)_2$

(iii) $(11011)_2 - (10000)_2$

(iv) $(111011)_2 - \{(1010)_2 + (1001)_2\}$

(v) $(11111111)_2 \times (11011)_2$

(vi) $(2244)_5 + (4433)_5$

(vii) $(340102)_5 + (230124)_5$

(viii) $(100001)_5 - (33322)_5$

(ix) $(44143)_5 \times (23023)_5$

(x) $(43230)_5 \times (2412)_5$

(xi) $(5631)_8 + (2456)_8$

(xii) $(7541)_8 - (5675)_8$

(xiii) $(4672)_8 \times (507)_8$

(xiv) $(2465)_8 \times (465)_8$

(xv) $635 - \{(2244)_5 - (1243)_5 - (110111)_2\}$

2. Evaluate and express the answer with bases 2, 5 and 8.
- (i) $(75)_8 + (1342)_5 + (100111)_2$
- (ii) $248 + (3124)_5 - (110110)_2$
- (iii) $(563)_8 - \{(4433)_5 - (2134)_5 - (111011)_2\}$
- (iv) $(3344)_5 + \{(4101)_5 + (217)_8 + (1010101)_2 - (11011)_2\}$
- (v) $(6767)_8 - \{(101111101)_2 - (4213)_5 + (1423)_5 - (1110111001)_2\}$
- (vi) $(1423)_5 \times (110011)_2 - (243)_5$
- (vii) $(1010111010)_2 \times (40401)_5 + (4301)_5 \times (111001)_2$
- (viii) $\{(3404)_5 + (1100101)_2\} \{(3404)_5 - (1100101)_2\}$
- (ix) $\{(467)_8 + (101110011)_2\} \times \{(467)_8 + (3004)_5\}$
- (x) $\{(31234)_5 + (10110111)_2\} \{2459 - (1342)_5\}$

REVIEW EXERCISE 3

1. Four options are given against each statement. Encircle the correct one.
- i. Only 0, 1, 2, 3 and 4 are used in:
- | | |
|--------------------|------------------------|
| (a) binary system | (b) octal system |
| (c) decimal system | (d) system with base 5 |
- ii. The place value of 10^3 is:
- | | | | |
|--------|---------|---------|----------|
| (a) 30 | (b) 300 | (c) 100 | (d) 1000 |
|--------|---------|---------|----------|
- iii. $(100)_2$ in decimal system is written as:
- | | | | |
|-------|-------|-------|--------|
| (a) 2 | (b) 4 | (c) 7 | (d) 10 |
|-------|-------|-------|--------|
- iv. $(304)_5$ in decimal system is written as:
- | | | | |
|--------|--------|--------|--------|
| (a) 75 | (b) 79 | (c) 30 | (d) 34 |
|--------|--------|--------|--------|
- v. $(11)_2 + (10)_2 = ?$
- | | | | |
|---------------|---------------|---------------|--------------|
| (a) $(110)_2$ | (b) $(101)_2$ | (c) $(111)_2$ | (d) $(11)_2$ |
|---------------|---------------|---------------|--------------|
- vi. $(3)_5 \times (4)_5 = ?$
- | | | | |
|--------------|--------------|--------------|--------------|
| (a) $(22)_5$ | (b) $(33)_5$ | (c) $(34)_5$ | (d) $(12)_5$ |
|--------------|--------------|--------------|--------------|
- vii. $(400)_5 - (33)_5 = ?$
- | | | | |
|---------------|---------------|------------------|------------------|
| (a) $(312)_5$ | (b) $(367)_5$ | (c) $(312)_{10}$ | (d) $(367)_{10}$ |
|---------------|---------------|------------------|------------------|
2. Answer the following questions.
- i. Define the binary system
- ii. Write the digits used in octal system.
- iii. Define decimal number system.
- iv. Which is the biggest digit used in system with base 2?

3. Express the following as decimal numbers.
 i. $(101)_2$ ii. $(1000)_2$ iii. $(2003)_5$ iv. $(3276)_8$ v. $(1134)_5$
4. Convert the following into number with base 5 and octal system.
 i. 154 ii. 820 iii. 2640 iv. 51605 v. 898
5. Solve the following:
 i. $(11001)_2 + (101)_2$ ii. $(100111)_2 + (10111)_2$
 iii. $(10000)_2 - (111)_2$
6. Evaluate the following:
 i. $(21304)_5 + (2003)_5$ ii. $(4001)_5 - (302)_5$
 iii. $(2442)_5 + (4043)_5$ iv. $(212)_5 \times (34)_5$
7. Solve the following:
 i. $(546)_8 + (327)_8$ ii. $(7000)_8 - (4456)_8$
 iii. $(7643)_8 \times (2346)_8$ iv. $(467)_8 \times (433)_8$
8. Evaluate and express the answer into decimal number system.
 i. $(2273)_8 - \{(104)_5 + (42)_5\}$ ii. $\{(80)_{10} + (241)_5\} + \{(34)_5 - (111)_2\}$
 iii. $[278819 - \{60065 - ((202)_5 + (101)_2)\}]$

SUMMARY

- The number system with base 2 is also called “Binary number system”.
- All the numbers in binary number system are represented by only two digits 0 and 1.
- All the binary numbers can be represented by the sum of multiples of power of base 2.
- In base 5 number system, five digits 0, 1, 2, 3 and 4 are used to represent numbers in the system.
- All the base 5 numbers can be represented by the sum of multiples of power of base 5
- The number system with base 8 is also called “Octal number system”.
- In octal number system eight digits 0, 1, 2, 3, 4, 5, 6 and 7 are used to represent numbers in the system.
- All the octal numbers can be represented by the sum of multiples of power of base 8.
- In decimal number system numbers are represented by ten digits 0, 1, 2, 3, 4, 5, 6, 7, 8 and 9.
- Decimal number system is a place value system in which value of each position is some power of 10 starting from zero onwards.
- To convert a number from one system to another system, the method of successive division by the base is used.

Unit - 4



Financial Arithmetic

After completion of this unit, the students will be able to:

- Define compound proportion.
- Solve real life problems involving compound proportion, partnership and inheritance.
- Define commercial bank deposits, types of a bank account (PLS saving account, current deposit account, PLS term deposit account and foreign currency account).
- Describe negotiable instruments like cheque, demand draft and pay order.
- Explain online banking, transactions through ATM (Auto Teller Machine), debit card and credit card (Visa and Master).
- Convert Pakistani Currency to well-known international currencies.
- Calculate:
 - The profit/markup,
 - The principal amount,
 - The profit/markup rate,
 - The period.
- Explain:
 - Overdraft (OD),
 - Running Finance (RF),
 - Demand Finance (DF),
 - Leasing.
- Solve real life problems related to banking and finance.
- Find percentage profit and percentage loss,
- Find percentage discount.
- Solve problems involving successive transactions.
- Define insurance.
- Solve real life problems regarding life and vehicle insurance.
- Explain income tax, exempt income and taxable income.
- Solve simple real life problems related to individual income tax assesse.

4.1 COMPOUND PROPORTION

We have learnt in previous grades that the equality of two ratios is called a proportion.

If four quantities a, b, c and d are in proportion then mathematically these are written as $a : b :: c : d$.

In fact it is a relationship between two ratios $a : b$ and $c : d$.

Proportion is of two kinds:

- (i) Direct proportion
- (ii) Inverse proportion

(i) Direct proportion

The relationship between two ratios in which increase or decrease in one quantity causes a proportional increase or decrease in the second quantity is called direct proportion.

Example 1: If the price of 12 eggs is Rs.96, how many eggs can be bought with Rs.80?

Solution:

We see that as the amount decreases the number of eggs also decreases. So it is a direct proportion.

Let the number of eggs be x .

$$\begin{array}{ccccccc} \text{Eggs} & : & \text{Eggs} & : & \text{Rs.} & : & \text{Rs.} \\ 12 & : & x & : & 96 & : & 80 \end{array}$$

$$\Rightarrow \frac{12}{x} = \frac{96}{80}$$

$$\Rightarrow 96 \times x = 12 \times 80$$

$$\Rightarrow x = \frac{12 \times 80}{96} = 10 \text{ eggs}$$

In vertical form it can be written as:

$$\begin{array}{ccc} \text{Eggs} & : & \text{Rupees} \\ 12 & \uparrow & 96 \\ x & \uparrow & 80 \end{array}$$

$$\Rightarrow \frac{x}{12} = \frac{80}{96}$$

$$\Rightarrow x = \frac{80 \times 12}{96} = 10 \text{ eggs}$$

(ii) Inverse proportion

The relationship between two ratios in which increase in one quantity causes a proportional decrease in the second quantity and vice versa is called an inverse proportion.

Example 2: 10 men have ration for 21 days in a camp. If 3 men leave the camp, for how many days will the ration be sufficient for the remaining men?

Solution:

Total men = 10

The men leave the camp = 3

The remaining men = 7

We see that as the number of men decreases, the ration will be sufficient for more days (days increase). So it is an inverse proportion.

Let the number of days be x

Men : **Men :** **Days :** **Days**
 10 : 7 : 21 : x

In vertical form we can write it as:

$$\begin{array}{ccc}
 \text{Men} & : & \text{Days} \\
 10 \downarrow & & 21 \uparrow \\
 7 & & x
 \end{array}$$

$$\Rightarrow \frac{x}{21} = \frac{10}{7}$$

$$\Rightarrow x = \frac{10 \times 21}{7} = 30 \text{ days}$$

Thus the ration (food) will be sufficient for 30 days.

4.1.1 Definition of compound proportion

The relationship between two or more proportions is known as compound proportion.

4.1.2 Solve real life problems involving compound proportion, partnership and inheritance**(a) Compound proportion**

The procedure of solving questions relating to the compound proportion is illustrated below with the help of examples.

Example 3: If 35 labourers dig 805 cm^3 of earth in 5 hours, how much of the earth will 30 labourers dig in 6 hours?

Solution: As the number of labourers decrease, the earth dug will also decrease. It is a direct proportion.

As the working time increase, the earth dug will also increase. It is also a direct proportion.

Let the earth dug be $x \text{ cm}^3$

Labourers 35 ↑ 30 ↑	:	Hours 5 ↑ 6 ↑	:	Earth (cm^3) 805 ↑ x ↑
----------------------------------	---	----------------------------	---	---

$$\Rightarrow \frac{x}{805} = \frac{6}{5} \times \frac{30}{35}$$

$$\Rightarrow x = \frac{6 \times 30 \times 805}{35}$$

$$x = 6 \times 6 \times 23$$

$$x = 828 \text{ cm}^3$$

Thus, 828 cm^3 earth will be dug.

Example 4: Rs.8,000 are sufficient for a family of 4 members for 40 days. For how many days Rs.15,000 will be sufficient for a family of 5 members?

Solution: We see that as amount increases the number of days also increases. So it is direct proportion.

As the members of a family increase the number of days decrease. So it is an inverse proportion.

Let the number of days be x .

Rupees 8,000 ↑ 15,000 ↑	:	Members 4 ↓ 5 ↓	:	Days 40 ↑ x ↑
--------------------------------------	---	------------------------------	---	----------------------------

$$\Rightarrow \frac{x}{40} = \frac{4}{5} \times \frac{15000}{8000}$$

$$\text{or } x = \frac{4 \times 15000 \times 40}{8000}$$

$$x = 4 \times 15 = 60 \text{ days}$$

Thus, the amount shall be sufficient for 60 days.

Example 5: If 4200 men have sufficient food for 32 days at a rate of 12 hectogram per person, how many men may leave so that the same food be sufficient for 42 days at a rate of 16 hectogram per person?

Solution: As the number of days increase, the number of men decreases. So, it is an Inverse Proportion.

As the quantity of food increases the number of men decreases. So it is also Inverse Proportion.

Let the number of men be x .

Days	:	Food	:	Men
32		12		4200
42	↓	16	↓	x
	↓			↑

$$\Rightarrow \frac{x}{4200} = \frac{32}{42} \times \frac{12}{16}$$

$$\text{or } x = \frac{2 \cancel{32} \times 12 \times \cancel{4200}^{100}}{1 \cancel{42} \times \cancel{16}_1}$$

$$x = 2 \times 12 \times 100$$

$$= 2400 \text{ men}$$

Thus, the food will be sufficient for 2400 men. So, $4200 - 2400 = 1800$ men may leave.

EXERCISE 4.1

1. 30 men repair a road in 56 days by working 6 hours daily. In how many days 45 men will repair the same road by working 7 hours daily?
2. If 60 women spin 48 kg of cotton by working 8 hours daily, how much cotton will 30 women spin by working 12 hours daily?
3. If the price of a carpet 8 metre long and 3 metre wide is Rs. 6288, what will be the price of 12 metre long and 6 metre wide carpet?
4. If 15 laboures earn Rs. 67,500 in 9 days, how much money will 10 laboures earn in 12 days?
5. 70 men can complete a wall of 150 metre length in 12 days. How many men will complete the wall of length 600 metre in 30 days?
6. If the fare of 12 quintal luggage for a distance of 18 km is 12 rupees, how much fare will be charged for a luggage of 9 quintals for a distance of 20 km?

7. 14 masons can build a wall 12 metres high in 12 days. How many masons will be needed to build a wall 120 metre high in 7 days?
8. 15 machines prepare 360 sweaters in 6 days. 3 machines get out of order. How many sweaters can be prepared in 10 days by the remaining machines?
9. 1440 men had sufficient food for 32 days in a camp. How many men may leave the camp so that the same food is sufficient for 40 days when the ration is increased by $1\frac{1}{2}$ times? [Hint: The 1st element (food) is 1 and the 2nd element (food) is $\frac{3}{2}$]
10. Ten men can assemble 400 cycles in 8 days. How many cycles 5 men will assemble if they work for 16 days?

(b) Partnership

A business in which two or more persons run the business and they are responsible for the profit and loss is called the partnership.

If the partners start the business and close it together with same or different investment capital, this partnership is called a simple partnership.

If the partners contribute different capitals for different time periods or at least one partner contributes two or more capitals for different time periods, then this partnership is called a compound partnership. In this case the profit or loss is divided in the ratio of monthly investments.

Example 6: Saud and Ammar started a business with capitals of Rs.56,000 and Rs.64,000 respectively. After one year they earned a profit of Rs.22,500. Find the share of each one.

Solution: The simplified form of capital share ratio:

Saud's share	:	Ammar's Share
$56,000$:	$64,000$
56	:	64
7	:	8
Sum of ratios	=	$7 + 8 = 15$
Total Profit	=	Rs. 22,500
Saud's Profit	=	$\frac{7}{15} \times 22500 = 1500$
	=	$7 \times 1500 = \text{Rs. } 10,500$
Ammar's Profit	=	$\frac{8}{15} \times 22500$
	=	$8 \times 1500 = \text{Rs. } 12,000$

Example 7:

Tahir started a business with a capital of *Rs. 15,000*. After 5 months Umar also joined him with an investment of *Rs. 30,000*. At the start of 9 month's Usman joined them by investing *Rs. 45,000*. At the end of the year they earned a profit of *Rs. 406000*. Find the share of each one.

Solution:

$$\begin{aligned}
 \text{Tahir's investment for 12 months} &= \text{Rs. } 15,000 \\
 \text{Tahir's effective investment for 1 month} &= 15000 \times 12 \\
 &= \text{Rs. } 180000 \\
 \text{Umar's investment for 7 months} &= \text{Rs. } 30,000 \\
 \text{Umar's effective investment for 1 month} &= 30,000 \times 7 \\
 &= \text{Rs. } 210000 \\
 \text{Usman's investment for 3 months} &= \text{Rs. } 45,000 \\
 \text{Usman's effective investment for 1 month} &= 45000 \times 3 \\
 &= \text{Rs. } 135000
 \end{aligned}$$

Ratios of Capitals

$$\begin{array}{rcccc}
 \textbf{Tahir} & : & \textbf{Umar} & : & \textbf{Usman} \\
 180\ 000 & : & 210\ 000 & : & 135\ 000 \\
 180 & : & 210 & : & 135 \\
 12 & : & 14 & : & 9
 \end{array}$$

$$\text{Sum of ratios} = 12 + 14 + 9 = 35$$

$$\begin{aligned}
 \text{Tahir's share} &= \frac{12}{35} \times \frac{81200}{7} \times 11600 \\
 &= 12 \times 11600 = \text{Rs. } 139200
 \end{aligned}$$

$$\begin{aligned}
 \text{Umar's share} &= \\
 &= 14 \times 11600 = \text{Rs. } 162400
 \end{aligned}$$

$$\begin{aligned}
 \text{Usman's share} &= \\
 &= 9 \times 11600 = \text{Rs. } 104400
 \end{aligned}$$

Example 8:

Saud, Ali and Saad started a business with *Rs.15,000*, *Rs.19,000* and *Rs.12,000* respectively. Saud manages the business and receives allowance of *Rs. 16,000* for this assignment. After 5 months Ali withdraws *Rs.9,000* and business is closed after 9 months. What did each receive in the profit of *Rs. 58,000*.

Solution:

Saud's capital for 9 months	=	<i>Rs. 15,000</i>
Saud's effective capital for 1 month	=	<i>15000 × 9</i>
	=	<i>Rs. 135,000</i>
Ali's capital for 5 months	=	<i>Rs. 19,000</i>
Ali's effective capital for 1 month	=	<i>19,000 × 5</i>
	=	<i>Rs. 95,000</i>
Ali's capital for 4 months	=	<i>Rs. 10,000</i>
Ali's effective capital for 1 month	=	<i>10,000 × 4</i>
	=	<i>Rs. 40,000</i>
Ali's total capital	=	<i>95,000 + 40,000</i>
	=	<i>Rs. 135000</i>
Saad's capital for 9 months	=	<i>Rs. 12,000</i>
Saad's effective capital for 1 month	=	<i>12,000 × 9</i>
	=	<i>Rs. 108000</i>
Total Profit	=	<i>Rs. 58,000</i>
Saud's Allowance	=	<i>Rs. 16,000</i>
Net Profit = <i>58,000-16000</i>	=	<i>Rs. 42,000</i>

Ratios of capital:

Saud's	:	Ali's	:	Saad's
<i>135000</i>	:	<i>135000</i>	:	<i>108000</i>
<i>135</i>	:	<i>135</i>	:	<i>108</i>
<i>15</i>	:	<i>15</i>	:	<i>12</i>
<i>5</i>	:	<i>5</i>	:	<i>4</i>

$$\text{Sum of ratios} = 5 + 5 + 4 = 14$$

$$\begin{aligned} \text{Saud's Profit} &= \frac{5}{14} \times \cancel{42,000}^{3000} \\ &= 5 \times 3000 \\ &= \text{Rs. } 15,000 \end{aligned}$$

$$\text{Saud's Allowance} = \text{Rs. } 16,000$$

$$\begin{aligned} \text{Saud received} &= \text{Total of Saud's Profit} + \text{Allowance} \\ &= 15,000 + 16,000 = \text{Rs. } 31,000 \end{aligned}$$

$$\begin{aligned}\text{Ali's Profit} &= \frac{5}{14} \times 42000 \\ &= 5 \times 3000 \\ &= \text{Rs. } 15,000\end{aligned}$$

$$\begin{aligned}\text{Saad's Profit} &= \frac{4}{14} \times 42000 \\ &= 4 \times 3000 \\ &= \text{Rs. } 12,000\end{aligned}$$

EXERCISE 4.2

- Aslam and Akram invested *Rs. 27,000* and *Rs. 30,000* to start a business. If they earned a profit of *Rs. 66,500* at the end of the year, find the profit of each one.
- Amina and Maryam started a business with investment of *Rs. 30,000* and *Rs. 40,000* respectively in one year. At the end of the year they earned a profit of *Rs. 8400*. Find the share of each one.
- Two partners contributed *Rs. 4000* and *Rs. 3000*. *1st* contributed for 9 months and the *2nd* contributed the amount for 7 months. Divide a profit of *Rs. 11590* between the partners.
- Saad, Saud and Saeed started a business with capital of *Rs. 12,000*, *Rs. 18,000* and *Rs. 24,000* respectively. At the end of the year, they suffered with a loss of *Rs. 13,500*. Find the share of each in this loss.
- Akram and Asghar started a business with *Rs. 9,000* and *Rs. 11,000* respectively. Akram withdraws *Rs. 1000* after 6 months. After 2 months of his withdrawal Asghar invested *Rs. 1000* more. After a year they earned a profit of *Rs. 14,000*. Find the share of each in the profit.
- Three friends *A*, *B* and *C* started a firm with *Rs. 20,000*, *Rs. 16,000* and *Rs. 18,000* respectively. *A* kept his money for 4 months, *B* for 6 months and *C* for 8 months. Divide a profit of *Rs. 12,000* among these friends.
- Aslam started a business with *Rs. 35,000*. After 3 months Akram joined the business with *Rs. 4000* and after 6 months Asghar invested *Rs. 5000*. At the end of the year they earned a profit of *Rs. 1620*. Find the share of each in the profit.

(C) Inheritance

When a person dies, then the assets left by him are called inheritance and it is distributed among his legal inheritors according to Islamic Shariah Law. In Islam the principles of distribution of inheritance are given below.

- First of all his/her funeral expenses and all his/her all debt be paid.
- Then execute the will upto $\frac{1}{3}$ of his/her property if asked for.
- Then distribute the remaining inheritance accordingly.

The procedure is illustrated with the help of following examples.

Example 9: A man left his property of Rs. 640000. A debt of Rs. 40,000 was due to him and Rs. 5,000 was spent on his burial. Distribute the amount between his widow, 1 daughter and 2 sons according to the Islamic Law.

Solution:

$$\begin{aligned} \text{Total amount of Property} &= \text{Rs. } 640000 \\ \text{His debt} &= \text{Rs. } 40,000 \\ \text{Burial Expenses} &= \text{Rs. } 5,000 \\ \text{Total Amount paid} &= 40,000 + 5,000 = \text{Rs. } 45,000 \\ \text{Remaining amount} &= 640000 - 45,000 \\ &= \text{Rs. } 595000 \\ \text{Widow's Share} &= \frac{1}{8} \times 595000 \\ &= \text{Rs. } 74,375 \\ \text{Remaining Inheritance} &= 595000 - 74,375 \\ &= \text{Rs. } 520625 \end{aligned}$$

Now ratios of shares

$$\begin{array}{ccc} \text{Sons} & : & \text{Daughter} \\ 2 & : & 1 \\ 2 \times 2 = 4 & : & 1 \times 1 = 1 \end{array}$$

$$\text{Sum of ratios} = 4 + 1 = 5$$

$$\begin{aligned} \text{Share of 2 Sons} &= \frac{4}{5} \times 520625 \\ &= 4 \times 104125 \\ &= \text{Rs. } 416500 \end{aligned}$$

$$\text{Share of each son} = \frac{416500}{2} = \text{Rs. } 208250$$

$$\begin{aligned} \text{Share of one daughter} &= \frac{1}{5} \times 520625 \\ &= \text{Rs. } 104125 \end{aligned}$$

Example 10: Mst. Zainab Begum died leaving behind her a property of Rs. 802500 which was to be distributed among her husband, her mother and two daughters. The husband got $\frac{1}{4}$, mother got $\frac{1}{6}$ and remaining for 2 daughters. Rs. 7,500 was spent on her burial. Find the share of each one.

Solution:

$$\begin{aligned} \text{Total amount left} &= \text{Rs. } 802500 \\ \text{Expenditure on her burial} &= \text{Rs. } 7,500 \\ \text{Remaining amount} &= 802500 - 7,500 \\ &= \text{Rs. } 795000 \end{aligned}$$

$$\begin{aligned}
 \text{Share of her husband} &= \frac{1}{4} \times 795000 \\
 &= \text{Rs. } 198750 \\
 \text{Share of her mother} &= \frac{1}{6} \times 795000 \\
 &= \text{Rs. } 132500 \\
 \text{Total share of her husband and her mother} &= 198750 + 132500 \\
 &= \text{Rs. } 331250 \\
 \text{Remaining Inheritance} &= 795000 - 331250 \\
 &= \text{Rs. } 463750 \\
 \text{Share of 2 daughters} &= \text{Rs. } 463750 \\
 \text{Share of each daughter} &= \frac{463750}{2} \\
 &= \text{Rs. } 231875
 \end{aligned}$$

EXERCISE 4.3

1. A man left *Rs. 240000* as inheritance. His heirs are 6 daughters and 2 sons. Find the share of each such in heritor that a son gets twice of his sister's share.
2. Allah Ditta died leaving a property of *Rs. 850000*. He left a widow, two sons and one daughter. Find the share of each in the inheritance if the burial expenditure was *Rs. 50,000*.
3. Akram left a wealth of *Rs. 780000*. His heir is a widow, 3 sons and 4 daughters. Calculate the share of each one if the funeral expenses is *Rs. 30,000* and a loan of *Rs. 50,000* is due to him.
4. A man died leaving a saving of *Rs. 72,000* in the bank. Find the share of each: widow, one son and one daughter.
5. Aslam left a property worth *Rs. 650000*. He had to pay *Rs. 50,000* as debt. The remaining amount was divided among his 2 sons and 2 daughters. Find the share of each.
6. Asghar Ali died leaving assets worth *Rs. 655275*. Funeral expenses were *Rs. 5275*. He had to pay *Rs. 50,000* as debt. After marking these payments, his widow shall get $\frac{1}{8}$ of the remaining property. Find the share of his son and one daughter when share of son is double the share of his daughter.

7. A person died leaving behind inheritance of Rs. 300000. Distribute the amount among 4 sons and 3 daughters so that each son gets double of what a daughter gets. Find the share of each when a debt of Rs. 80,000 was also to be paid.
8. Wife of Ahmad died leaving behind 2 daughters and a son. Ahmad got $\frac{1}{4}$ of the inheritance of Rs. 180000. The remaining amount was to be distributed among her children such that each son got twice of what a daughter got. Find the share of her son and each daughter.

4.2 BANKING

It is a business activity of accepting and safeguarding the money and then earn a profit by lending out this money.

4.2.1 Define Commercial Bank deposits

The function of bank which accepts deposits, provides loans and other services to the clients is known as commercial banking.

4.2.1.1 Types of a Bank Account

There are four types of bank accounts.

- **PLS Saving Bank Account:**

It is an account on the basis of profit and loss sharing. The bank uses the deposits in some business and gives the share in profit and loss to the account holder at the end of specified period. This account is meant to encourage the saving habits among the persons having small income means. Zakat is deducted on notified balance on first Ramadan each year.

- **Current Deposit Account:**

This account is usually opened by businessmen who have a number of deposits and withdrawal regularly. It is a running account and no interest is paid on its balance. In this account amount can be deposited and withdrawn at any time during banking hours without any notice. No Zakat is deducted on this account.

- **PLS Term Deposit Account:**

This account is free of interest. PLS term deposit holder shares profit and loss on the rate determined by the bank after every six months. The rate of profit on fixed deposits is comparatively higher than saving deposits.

- **Foreign Currency Account:**

A foreign currency account is the account maintained in a commercial bank in the currency other than Pakistani currency. Usually foreign currency accounts are maintained in Dollars, Pounds, Euro etc. Foreign currency accounts are exempted from Zakat and taxes. Rate of profit in this account is very low.

4.2.1.2 Describe negotiable instruments like cheque, demand draft and pay order

Negotiable Instrument:

It is a document which can be transferred from one person to another. It is payable either to the order of the bearer or to his agent as the case may be. This document is entitled to receive that amount which is mentioned in it.

Cheque:

A cheque is a written order that instructs a bank to pay the specific amount from a specified account to the holder of the cheque. A crossed cheque has to be deposited in the specified account.

Demand Draft:

It is a method used by individuals to make transfer payments from one bank account to another. The bank receives the money in advance before it issues the draft. A very small fee is charged by the bank to prepare it.

Pay order:

It is a document which instructs a bank to pay a certain amount to a third party. Pay order is issued by the bank on the request of its customer. It is issued on the receipt of full amount for which a pay order is issued by the bank. It can be encashed from any other bank.

4.2.2 On-line Banking

4.2.2.1 Explain On-line Banking

The use of internet by banks to assist their customers through on-line banking. It allows customers to perform banking transactions such as money withdrawal, pay utility bills and transfer funds from their account to another account. A good online bank will offer its customers just about every service traditionally available through a local branch.

- **Transactions through ATM (Auto Teller Machine)**

An automated teller machine (ATM) is electric devices that allows a bank's customer, to draw cash and check their account balances without any need for a humane teller. The transactions are as given below:

Withdraw money, make deposits, print a statement, check account balances and trasfer money between accounts.

- **Debit Card**

It is a plastic payment card that provides card holder electronic access to his bank account at anytime and anywhere. It is a facility provided to the customers to perform different transactions. It is a smarter and secured way to make quick payments at the time of purchase of different goods from traditional or online market.

- **Credit Card (Visa and Master)**

It is a thin plastic card which can be used to buy articles. Visa and Master cards are used worldwide for making payments. These are not the names of cards but are the names of global credit card companies. Credit card holder is charged an annual fee.

4.2.3 Conversion of Currencies

A foreign currency exchange rate is a price that represents how much it costs to buy the currency of one country using the currency of another country.

4.2.3.1 Convert Pakistani Currency to well-known international currencies

Currency conversion rates are not permanent but these change day by day. We use these currency rates to convert Pakistani currency to different international currencies. (rate of US \$ is equal to Rs. 99.80)

Example 1: Mr. Saud wants to exchange Pakistani Rupees (PKR). 50,000 to US dollars. How many US Dollars will he receive? (Rate of US \$ = Rs 99.80)

Solution: Amount to be converted = Rs. 50,000
 Rate of one US Dollar = Rs. 99.80

$$\text{Number of US Dollars} = \frac{50,000}{99.80} = \text{US } \$ 501$$

Example 2: Convert Rs. 75,810 into UK£. (1 UK Pound = Rs. 168.50)

Solution: Amount to be converted = Rs. 75810
 Rate of 1UK £ = Rs. 168.50

$$\text{Number of UK } \pounds = \frac{75810}{168.50} = \text{UK} \pounds 449.91$$

Table below shows current rate exchange rates of some currencies.

Country	Currency	Symbol	Buying(PKR)	Selling(PKR)
US	Dollar (\$)	\$	99.80	99.05
UK	Pound (£)	£	168.50	168.75
Saudi	Riyal (SR)	SAR	26.85	27.10
Indian	Rupee	₹	1.60	1.65

EXERCISE 4.4

1. Convert Rs. 70,000 into US \$ if the conversion rate is 1 US \$ = Rs.99.80.
2. Convert Rs. 75,000 into UK £. (Rate 1UK £ = Rs.168.50).
3. Convert Rs. 50,000 into Saudi Riyal. (Rate 1 SAR=Rs. 26.85).
4. Convert Rs. 48,000 into Indian Rupee. (1 INR = Rs. 1.60).
5. Convert Rs. 35,000 into Australian Dollar. (1 Australian Dollar=Rs.92.77).
6. Convert Rs. 80,000 into Chinese Yaun. (1 Chinese Yaun=Rs. 15.91).
7. Convert Rs. 50,000 into Canadian Dollar. (1 Canadian Dollar=Rs.92.00).
8. Convert Rs.70,000 into Turkish Lira. (1 Turkish Lira=Rs. 46.50).

4.2.4 Profit / Markup

- **Profit**

When we deposit money into a bank, the bank uses our money and in return pays an extra amount alongwith our actual deposit. The extra money which the bank gives for the use of our amount is called profit on the deposit.

- **Markup**

When we borrow money from bank to run a business, the bank in return receives some extra amount alongwith the actual money given. This extra money which the bank receives is known as markup.

- **Principal amount**

The amount we borrow or deposit in the bank is called principal amount.

- **Profit / Markup rate**

The rate at which the bank gives share to its account holders is known as profit / markup rate. It is expressed in percentage.

- **Period**

The time for which a particular amount is invested in a business is known as period.

4.2.4.1 Calculate the profit / markup, the Principal amount, the profit / markup rate, the period

- **Calculate profit / markup**

For calculation of profit / markup, we use the formula.

$$\text{Profit / markup} = \text{Principal} \times \text{Time} \times \text{Rate}$$

$$\text{or } I = P \times R \times T$$

The use of this formula is illustrated with the help of examples.

Example 3:

Younas borrowed Rs. 65,000 from a bank at the rate of 5% for 2 years. Find the amount of markup and the total amount to be paid.

Solution:

Here principal (P) = Rs. 65,000

Rate = 5%

Time (T) = 2 years

Markup = $P \times R \times T$

$$\text{Markup} = 65,000 \times \frac{5}{100} \times 2$$

$$= 650 \times 5 \times 2$$

$$= \text{Rs. } 6,500$$

So, Younas will have to pay Rs. 6,500 as markup.

$$\text{Total amount to be paid} = 65,000 + 6,500 = \text{Rs. } 71,500$$

Example 4:

A student purchased a computer by taking loan from a bank on simple interest. He took loan of Rs. 25,000 at the rate of 10% for 2 years. Calculate the markup to be paid and the total amount to be paid back.

Solution:

$$\begin{aligned} \text{Here } \textit{Principal (P)} &= \text{Rs. } 25,000 \\ \text{Rate (R)} &= 10\% \\ \text{Time (T)} &= 2 \text{ years} \\ \text{Markup} &= P \times R \times T \\ &= 25000 \times \frac{10}{100} \times 2 \\ &= 250 \times 20 = \text{Rs. } 5,000 \end{aligned}$$

He has to pay Rs. 5,000 as markup.

$$\text{Total amount to be paid} = 25,000 + 5,000 = \text{Rs. } 30,000$$

- **Calculate Principal Amount**

We have used formula of markup in the previous examples, we will use the same formula principal amount.

$$\begin{aligned} I &= P \times R \times T \\ P &= \frac{I}{R \times T} \end{aligned}$$

Example 5:

What principal amount is taken to bring in Rs. 640 as profit at the rate of 4% in 2 years?

Solution:

$$\begin{aligned} \text{Profit} &= \text{Rs. } 640 \\ \text{Rate (R)} &= 4\% \\ \text{Time (T)} &= 2 \text{ years} \\ \textit{Principal} &= \frac{\text{Profit}}{R \times T} \\ &= \frac{\cancel{640}^{80} \times 100}{\cancel{4}^1 \times \cancel{2}^1} \\ &= 80 \times 100 \\ &= \text{Rs. } 8,000 \end{aligned}$$

Thus, the principal amount = Rs. 8,000

Example 6:

A person got some loan on which he has to pay Rs. 3,500 as markup at the rate of 10% for 3.5 years. What is the amount of loan?

Solution:

$$\text{Markup} = \text{Rs. } 3,500$$

$$\text{Rate (R)} = 10\%$$

$$\text{Time (T)} = 3.5 \text{ years} = \frac{7}{2} \text{ years}$$

$$\text{Principal (P)} = \frac{\text{Interest}}{\text{Rate} \times \text{Time}}$$

$$\begin{aligned} \text{Principal} &= \frac{3500 \times 100 \times 2}{10 \times 7} \\ &= 50 \times 200 \\ &= \text{Rs. } 10,000 \end{aligned}$$

Thus, the amount of loan = Rs. 10,000

- **Calculate Profit / Markup rate**

The formula for calculation of profit rate is $\text{Rate} = \frac{\text{Markup}}{\text{Principal} \times \text{Time}}$

Example 7:

At what annual rate percent of markup would the principal amount Rs. 68,000 become Rs. 86,360 in 3 years?

Solution:

$$\text{Total amount to be paid} = \text{Rs. } 86,360$$

$$\text{Principal} = \text{Rs. } 68,000$$

$$\begin{aligned} \text{Markup} &= 86,360 - 68,000 \\ &= \text{Rs. } 18,360 \end{aligned}$$

$$\text{Period / Time} = 3 \text{ years}$$

$$\text{Rate} = \frac{\text{Markup}}{\text{Principal} \times \text{Time}}$$

$$= \frac{18360 \times 100}{68000 \times 3}$$

$$= \frac{612}{68} = 9\%$$

$$\text{Rate of markup} = 9\%$$

- **Calculate the Period**

Example 8:

A person got loan from a bank at a rate of 3% per year for some period. In how much period his loan of Rs. 65,000 will become Rs. 68,900.

Solution:

$$\begin{aligned} \text{Total Amount} &= \text{Rs. } 68,900 \\ \text{Principal} &= \text{Rs. } 65,000 \\ \text{Markup} &= 68,900 - 65,000 \\ &= \text{Rs. } 3,900 \\ \text{Rate} &= 3\% \\ \text{Period / Time} &= ? \end{aligned}$$

$$\begin{aligned} \text{Period / Time} &= \frac{\text{Markup}}{\text{Principal} \times \text{Rate}} \\ &= \frac{3900}{65000 \times 3\%} \\ &= \frac{3900}{65000 \times \frac{3}{100}} \\ &= \frac{3900 \times 100}{65000 \times 3} \\ &= \frac{390000}{195000} \\ &= 2 \text{ years.} \end{aligned}$$

4.2.5 Types of Finance

4.2.5.1 Explain Overdraft (OD), Running Finance, Demand Finance and Leasing

- **Overdraft (OD):**

It is a borrowing facility provided by a bank to account holder to withdraw some amount in excess of his original account balance. In other words if there is no amount left in an account and the bank does not send a cheque back due to lack of funds in the drawer's account, then this is called Overdraft.

- **Running Finance:**

Running Finance is very similar to overdraft. The aim of running finance is to give a chance to the customers to withdraw more money that they actually have. Therefore it can be considered as a credit facility which is meant for a credit limit with a variable interest rate. Usually the running finance is granted for a period of 1 year.

- **Demand Finance:**

One can think of demand as a person's willingness to go out and buy a certain product. For example market demand is the total of what everybody in the market wants and is willing to pay for. To meet these requirements banks have demand finance. Demand is a type of loan that may be called in by the bank (or lender) at any time. It may be either short term or long term.

- **Leasing:**

A lease is a contractual agreement between the lessee (user) to pay the lessor (owner) for the use of an asset. It means the user rents the land or goods rented out by the owner. The ownership of the leased asset during the leased period known as term remains with the lessor. Hire purchase is a method of buying goods in which payments of purchase price is spread over specific term by payment of an initial deposit known as the down payment. It is explained with the help of examples.

4.2.5.2 Solve Real Life Problems Related to Banking and Finance

Example 9:

The price of a car is Rs. 450000. It can be bought at 15% of the price as down payment. It had to be leased on simple markup of $10\frac{1}{2}\%$ per year for 2 years. The installments will be made on monthly basis. Find

- The monthly installments
- The total leased price of the car paid.

Solution:

$$\begin{aligned}\text{Down payment} &= 15\% \text{ of } 450,000 \\ &= \frac{15}{100} \times 450,000\end{aligned}$$

$$\begin{aligned}&= 15 \times 4500 \\ &= \text{Rs. } 67,500\end{aligned}$$

$$\begin{aligned}\text{The remaining amount} &= 450000 - 67,500 \\ &= \text{Rs. } 382500\end{aligned}$$

$$I = P \times R \times T$$

$$\text{The markup on Rs. } 382500 \text{ for 2 years} = 382500 \times \frac{21}{2} \times \frac{1}{100} \times 2$$

$$\begin{aligned}&= 3825 \times 21 \\ &= \text{Rs. } 80,325\end{aligned}$$

Additional amount to be paid in 24 monthly installments

$$\begin{aligned}&= 382500 + 80,325 \\ &= \text{Rs. } 462825\end{aligned}$$

$$\begin{aligned}\text{(i) Monthly installments} &= 462825 \div 24 \\ &= \text{Rs. } 19,284.38\end{aligned}$$

$$\begin{aligned}\text{(ii) Total amount paid} &= 67,500 + 462825 \\ &= \text{Rs. } 530325\end{aligned}$$

Example 10:

A company gets a house on lease for 6 years. According to agreement the company paid Rs. 1000000 as down payment and shall pay Rs. 20,000 per month as rent. After 3 years the company shall increase the rent 3%. Calculate the total amount the lesser (owner) would get:

Solution:

$$\text{Down payment received by the owner} = \text{Rs. } 1000000$$

$$\text{Rent per month for 3 years} = \text{Rs. } 20,000$$

$$\begin{aligned} \text{Total rent for 3 years} &= 3 \times 12 \times 20,000 \\ &= \text{Rs. } 720000 \end{aligned}$$

$$\text{Rate of rent after 3 years} = 20,000 \times \frac{103}{100}$$

$$= \text{Rs. } 20,600$$

$$\begin{aligned} \text{Total rent for next 3 years} &= 3 \times 12 \times 20600 \\ &= \text{Rs. } 741600 \end{aligned}$$

$$\begin{aligned} \text{Total amount received by the owner} &= 1000000 + 720000 + 7,41,600 \\ &= \text{Rs. } 2461000 \end{aligned}$$

EXERCISE 4.5

- Find the profit on Rs. 40,000 at the rate of 3% per year for 4 years.
- Saud borrowed Rs. 25,000 from bank at the rate of 6% per year for 3 years. Find the markup of the bank.
- Find the principal amount invested by Riaz in a business if he receives a profit of Rs. 4200 in 3 years at the rate of 10% per year.
- Ajmal invested some amount in a business. He receives a profit of Rs. 27,000 at the rate of 12% per year for 3 years. Find his original investment.
- At what annual rate percent would Rs. 68,00 amount become Rs. 9,044 in 11 years?
- At what annual rate of profit would a sum of Rs. 5800 will increase to Rs. 7105 in 3 years' time?
- How long would Rs. 15,500 have to be invested at a markup rate of 6% per year to gain Rs. 2790.
- How long would Rs. 25,000 have to be deposited in the bank at 12% per year to receive back Rs. 31,000.
- Saeed invests Rs. 12,000 at $8\frac{1}{2}\%$ per year profit. How much would the amount be after 2 years and 6 months?
- Arshad buys an air-conditioner at Rs. 45,000. For leasing it, he has to pay 10% down payment and remaining amount on simple markup of 15% per year for 2 years on monthly investments. Find (i) Monthly installment and (ii) Total amount paid

11. A bank gets a piece of land on lease for 5 years. According to the agreement the bank paid Rs. 1200000 as down payment and shall pay Rs. 18,000 per month as rent. After 3 years the bank shall increase the rent by 3%. Find the total amount the owner (lessor) would get.

4.3 PERCENTAGE

The percentage means “per hundred” or “out of hundred”. The symbol used for percentage is %.

4.3.1 Profit and Loss:

If the selling price (S.P) is higher than the cost price (C.P), then profit occurs. It can be written as

$$\begin{aligned} \text{Profit} &= \text{Sale Price} - \text{Cost Price} \\ \text{or} \quad \text{Profit} &= \text{S.P} - \text{C.P} \end{aligned}$$

If the cost price (C.P) is higher than the selling price (S.P), then loss occurs. It can be written as

$$\begin{aligned} \text{Loss} &= \text{Cost Price} - \text{Sale Price} \\ \text{or} \quad \text{Loss} &= \text{C.P} - \text{S.P} \end{aligned}$$

4.3.1.1 Find Percentage Profit and Percentage Loss

Percentage profit or loss is always expressed in terms of cost price. To find percent profit and percentage loss we will use the following formulas accordingly.

$$\text{Percentage Profit} = \frac{\text{Profit}}{\text{Cost Price}} \times 100$$

$$\text{Percent Loss} = \frac{\text{Loss}}{\text{Cost Price}} \times 100$$

Example 1:

Saud bought a motor-cycle for Rs. 50,000 and sold it for Rs. 56,000. Find his percentage profit.

Solution:

$$\begin{aligned} \text{Cost Price (C.P)} &= \text{Rs. } 50,000 \\ \text{Sale Price (S.P)} &= \text{Rs. } 56,000 \\ \text{Profit} &= \text{S.P} - \text{C.P} \\ &= 56,000 - 50,000 \\ &= \text{Rs. } 6,000 \end{aligned}$$

$$\begin{aligned} \text{Profit \%} &= \frac{\text{Profit}}{\text{C.P}} \times 100 \\ &= \frac{6,000}{50,000} \times 100 \\ &= 12\% \end{aligned}$$

Example 2:

Hameed bought a piece of land worth *Rs. 300000* and sold, it for *Rs. 240000*. Find his profit / loss percentage?

Solution:

$$\begin{aligned}
 \text{Cost Price (C.P)} &= \text{Rs. } 300000 \\
 \text{Sale Price (S.P)} &= \text{Rs. } 240000 \\
 \text{Loss} &= \text{C.P} - \text{S.P} \\
 &= 300000 - 240000 \\
 &= \text{Rs. } 60,000 \\
 \text{Loss Percentage} &= \frac{\text{Loss}}{\text{C.P}} \times 100 \\
 &= \frac{20\cancel{00,000}}{1\cancel{00,000}} \times 100 \\
 &= \text{Rs. } 20\%
 \end{aligned}$$

4.3.2 Discount:

Discount means to reduce the price of an article from its market price which is also called list price or regular price. After reduction the amount is known as the sale price. The discount is the amount you saved in buying an article.

$$\text{Discount} = \text{Market price} - \text{Sale price}$$

The discount is usually expressed as the percentage of the market price.

4.3.2.1 Find Percentage Discount:

Following examples illustrate the procedure of finding percentage discount.

Example 3:

Ali bought some articles of worth *Rs. 2,500*. He was allowed *15%* discount on his purchase. Find sale price of the said articles.

Solution:

$$\begin{aligned}
 \text{Market price} &= \text{Rs. } 2500 \\
 \text{Discount} &= 15\% \\
 \text{Discount on the articles} &= \frac{2500 \times 15}{100} \\
 &= \text{Rs. } 375 \\
 \text{So, sale price} &= 2500 - 375 \\
 &= \text{Rs. } 2,125
 \end{aligned}$$

Example 4:

The market price of an article is Rs. 1,700. The sale price of the article is Rs. 1,360. Find the percentage discount.

Solution:

$$\begin{aligned}\text{Market Price} &= \text{Rs. } 1,700 \\ \text{Sale Price} &= \text{Rs. } 1,360 \\ \text{Discount} &= M.P - S.P \\ &= 1700 - 1360 \\ &= \text{Rs. } 340\end{aligned}$$

$$\begin{aligned}\text{Percentage discount} &= \frac{\text{Discount}}{\text{Market Price}} \times 100 \\ &= \frac{20}{100} \times 100 \\ &= 20\%\end{aligned}$$

4.3.2.2 Solve Problems Involving Successive Transactions**Example 5:**

The Cost Price of an article is Rs. 6,000. The shopkeeper writes the market price of the article 15% above the cost price. The sale price of that article is Rs. 4600. Find percentage discount given to the customer.

Solution:

$$\begin{aligned}\text{Cost Price} &= \text{Rs. } 6,000 \\ \text{Percentage increase} &= 15\% \\ \text{Total increase on Cost Price} &= \frac{6000 \times 15}{100} \\ &= \text{Rs. } 900 \\ \text{Market Price} &= 6000 + 900 \\ &= \text{Rs. } 6900 \\ \text{Sale Price} &= \text{Rs. } 4600 \\ \text{Discount} &= M.P - S.P \\ &= 6900 - 4600 \\ &= \text{Rs. } 2300 \\ \text{Percentage discount} &= \frac{\text{Discount}}{\text{Market Price}} \times 100 \\ &= \frac{1}{3} \times 100 \\ &= \frac{100}{3} = 33\frac{1}{3}\%\end{aligned}$$

Example 6:

A wholeseller sold an article to a retailer at a profit of 10%. The retailer sold it for Rs. 1897.50 at a profit of 15%. What is the cost of wholeseller?

Solution:

$$\text{Sale price of the retailer} = \text{Rs. } 1897.50 = \text{Rs. } \frac{3795}{2}$$

$$\text{Profit} = 15\%$$

$$\text{Cost price of retailer} = ?$$

$$\text{Let the cost price of the retailer} = \text{Rs. } 100$$

$$\text{Profit} = 15\%$$

$$\text{Sale price of retailer} = 100 + 15 = \text{Rs. } 115$$

$$\text{If the sale price of retailer is Rs. } 115, \text{ his cost price} = \text{Rs. } 100$$

$$\text{If the sale price of retailer is Rs. } 1, \text{ his cost price} = \frac{100}{115}$$

$$\text{If the sale price of retailer is Rs. } \frac{3795}{2} \text{ his cost price}$$

$$= \frac{50}{123} \times \frac{3795}{12}$$

$$= 50 \times 33$$

$$= \text{Rs. } 1,650$$

$$\text{The cost price of retailer} = \text{The sale price of wholeseller}$$

$$\text{Sale price of wholeseller} = \text{Rs. } 1,650$$

$$\text{Let the cost price of the wholeseller} = \text{Rs. } 100$$

$$\text{Profit} = 10\%$$

$$\text{Sale price of wholeseller} = 100 + 10 = \text{Rs. } 110$$

$$\text{If the sale price of wholeseller is Rs. } 110, \text{ then his cost price} = 100$$

$$\text{If the sale price of the wholeseller is Rs. } 1, \text{ then cost price} = \frac{100}{110}$$

$$\text{If the sale price of wholeseller is Rs. } 1,650, \text{ the cost price is}$$

$$= \frac{100}{110} \times 1650$$

$$= \text{Rs. } 1,500$$

$$\therefore \text{The cost of wholeseller} = \text{Rs. } 1,500$$

EXERCISE 4.6

1. Haneef bought a car for *Rs.550000*. He sold it for *Rs.605000* after some time. Find his profit percentage.
2. The market price of an article is *Rs.3000*. Discount on this article is *20%*. Find the sale price of the article.
3. A manufacturer sells an article which cost him *Rs.2,500* at *20%* profit. The purchaser sells the article at *30%* gain. Find the final sale price of the article.
4. The market price of every article was reduced by *12%* in sale at a store. A cash customer was given a further *10%* discount. What price would a cash customer pay for an article marked initially as *Rs.2000*?
5. Tahir purchased two toys for his children. He buys Spider Man and Barbie Doll for *Rs.3000*, and *Rs.5000* respectively. If a discount of *20%* is given on all toys, find the amount of discount and the sale price for each toy.
6. Tufail buys some items from a store. A special discount of *15%* is offered on food items and *20%* on other items. If he purchases food worth *Rs. 1250* and other items worth *Rs. 750*, find the amount of discount and sale price of each separately.
7. A wholeseller sets his sale price by adding *15%* to his cost price. The retailer adds *25%* to the price he pays to the wholeseller to fix his Sale Price. At what price would a retailer sell an article which cost the wholeseller *Rs.400*.

4.4 INSURANCE**4.4.1 Definition of Insurance:**

Insurance is a system of protecting or safeguarding against risk or injuries. It provides financial protection for property, life, health, etc. against specified contingencies such as death, loss or damage and involving payment of regular premium in return for a policy guaranteeing. The contract is called the insurance policy. The party bearing the risk is the insurer or assurer and the party whose risk is covered is known as insured or assured.

There are many different types of insurance including health, life, property, etc. We will learn about only two types in this grade namely (i) Life insurance and (ii) Vehicle insurance

4.4.2 Solve Real Life Problems Regarding Life and Vehicle Insurance

(i) Life Insurance:

Life insurance is an agreement between the policy owner and the insurance company for an agreed time period. Insurance company agrees to pay back a sum equal to original amount and the profit at the end of agreed period or on the death or critical illness of the policy owner. In return the policy owner agrees to pay regular installments of premium.

Example 1:

Saud got a life insurance policy of Rs. 500000. Rate of annual premium is 4.5% of the total amount of the policy whereas the policy fee is at the rate of 0.25%. Find the annual premium of the policy.

Solution:

$$\begin{aligned} \text{Policy amount} &= \text{Rs. } 500000 \\ \text{Policy fee @ } 0.25\% &= \frac{25}{100} \times 500000 \times \frac{1}{100} \\ &= \text{Rs. } 1250 \\ \text{First premium @ } 4.5\% &= \frac{45}{100} \times \frac{1}{100} \times 500000 \\ &= \text{Rs. } 22,500 \\ \text{Annual premium} &= \text{First premium} + \text{policy fee} \\ &= 22,500 + 1,250 \\ &= \text{Rs. } 23,750 \end{aligned}$$

Example 2:

A man purchased a life insurance policy for Rs. 300000. The annual premium is 4.5% of the policy amount whereas policy fee is at the rate of 0.25%. Calculate the annual premium and quarterly premium at 27% of the annual premium.

Solution:

$$\begin{aligned} \text{Policy amount} &= \text{Rs. } 300000 \\ \text{Policy fee @ } 0.25\% &= \frac{25}{100} \times \frac{1}{100} \times 300000 \\ &= \text{Rs. } 750 \\ \text{First premium @ } 4.5\% &= \frac{45}{100} \times \frac{1}{100} \times 300000 \\ &= \text{Rs. } 13,500 \\ \text{Annual premium} &= \text{First premium} + \text{policy fee} \\ &= 13500 + 750 \end{aligned}$$

$$\text{Annual premium} = \text{Rs. } 14,250$$

$$\begin{aligned} \text{Quarterly premium} &= \frac{285}{\cancel{1425} \cancel{0}} \times \frac{27}{\cancel{2} \cancel{10} \cancel{0}} \\ &= \frac{285 \times 27}{2} \\ &= \text{Rs. } 3847.50 \end{aligned}$$

(ii) Vehicle Insurance:

Vehicle insurance provides a protection against risks to the vehicle. The amount of policy in this case depends upon the actual value of the vehicle.

Example 3:

Aslam got his motorcycle insured for one year. The price of his motorcycle is *Rs. 50,000* and the rate of insurance is *4.5%*. Find the amount of premium.

Solution:

$$\begin{aligned} \text{The price of the motorcycle} &= \text{Rs. } 50,000 \\ \text{Rate of insurance} &= 4.5\% \\ \text{Amount of premium} &= \frac{4.5}{100} \times 50000 \\ &= \frac{45}{10} \times \frac{1}{100} \times \cancel{500} \cancel{00} \\ &= \text{Rs. } 2,250 \end{aligned}$$

Example 4:

Khalid purchased an insurance policy for his car. The worth of the car is *Rs. 750000*. The rate of annual premium is *3%* for two years and depreciation rate is *10%*. Find the total amount he paid as premium.

Solution:

$$\begin{aligned} \text{Worth of car} &= \text{Rs. } 750000 \\ \text{Rate of annual premium} &= 3\% \\ \text{Depreciation rate} &= 10\% \\ \text{Time period} &= 2 \text{ years} \\ \text{First premium} &= 3\% \text{ of } 750000 \\ \text{First premium} &= \frac{3}{100} \times \cancel{7500} \cancel{00} \\ &= \text{Rs. } 22,500 \\ \text{Depreciation after one year} &= 10\% \text{ of } 750000 \end{aligned}$$

$$\begin{aligned}
 \text{Depreciation after one year} &= \frac{10}{100} \times 750000 \\
 &= \text{Rs. } 75,000 \\
 \text{Depreciated price after one year} &= 750000 - 75,000 \\
 &= \text{Rs. } 675000 \\
 \text{2}^{\text{nd}} \text{ premium} &= 3\% \text{ of } 675000 \\
 &= \frac{3}{100} \times 6,75,000 \\
 &= \text{Rs. } 20,250 \\
 \text{Depreciation after 2 years} &= 10\% \text{ of } 675000 \\
 &= \frac{10}{100} \times 675000 \\
 &= \text{Rs. } 67,500 \\
 \text{Depreciated price after 2 years} &= 675000 - 67,500 \\
 &= \text{Rs. } 607500 \\
 \text{Total amount paid as premium} &= 22,500 + 20,250 \\
 &= \text{Rs. } 42,750
 \end{aligned}$$

EXERCISE 4.7

1. Usman purchased a car for *Rs.1250000* and insured it for one year at the rate of *4.5%*. Find the annual premium
2. Hameed got a life insurance policy of *Rs.200000*. Find the first premium he has to pay when the rate of annual premium is *5.2%* and policy fee is *0.25%*.
3. Zahid got a life insurance policy of *Rs.500000* at the rate of *5.2%* and the policy fee is *0.25%*. Calculate half yearly premium at *52%* of the annual premium.
4. Usama insured his life for *Rs.700000*. Find annual premium at *4.5%* of the policy amount with policy fee at the rate of *0.25%*. Calculate monthly premium at *9%* of the annual premium.
5. Saud bought a car for *Rs.700000* and got it insured at *4.2%* annual premium for 3 years. Calculate how much premium he paid in 3 years if depreciation rate is *12%*.
6. A man has a car of worth *Rs.1400000*. He got it insured for a period of 2 years at the rate of *4.5%*. The depreciation rate is *10%* per year. He has to pay the premium yearly. Find the total amount of premium he has to pay for a period of 2 years.
7. Faheem got his car insured at a rate of *3%* for 3 years. The worth of his car is *Rs.850000*. Find the total amount paid as premium if rate of depreciation is *10%* per year.

4.5 INCOME TAX

4.5.1 Explain Income Tax, Exempt Income and Taxable Income

- **Income Tax:**

Income tax is imposed on the annual income of a person whose income exceeds a certain limit which is determined by the government. The rules for income tax are amended by the government from time to time.

- **Exempt Income:**

Tax exempt-income is money on which a person does not have to pay tax. In other words it is income which is not subject to income tax.

- **Taxable Income:**

Taxable income is the difference of annual income and exempted income.

$$\text{Taxable Income} = \text{Annual Income} - \text{Exempted Income}$$

Taxable Income Slabs

Sr. #	Annual Income	Rate of Tax
1.	Rs. 0 to Rs. 400,000	0%
2.	Rs. 400001 to Rs. 750000	5% of the amount exceeding Rs. 400000
3.	Rs. 750001 to Rs. 1400000	Rs. 17500 + 10% of the amount exceeding Rs. 750000
4.	Rs. 1400001 to Rs. 1500000	Rs. 82,500 + 12.5% of the amount exceeding Rs. 1400000
5.	Rs. 1500001 to Rs. 1,800,000	Rs. 95,000 + 15% of the amount exceeding Rs. 1500000
6.	Rs. 1800001 to Rs. 2500000	Rs. 140000 + 17.5% of the amount exceeding Rs. 1800000
7.	Rs. 2500001 to Rs. 3000000	Rs. 262500 + 20% of the amount exceeding Rs. 2500000
8.	Rs. 3000001 to Rs. 3500000	Rs. 362500 + 22.5% of the amount exceeding Rs. 3000000
9.	Rs. 3,500,001 to Rs. 4000000	Rs. 475000 + 25% of the amount exceeding Rs. 3500000
10.	Rs. 4000001 to Rs. 7000000	Rs. 600000 + 27.5% of the amount exceeding Rs. 4000000
11.	Rs. 7000001 and above	Rs. 1425000 + 30% of the amount exceeding Rs. 7000000

4.5.2 Solve Simple Real Life Problems Related to Individual Income Tax Assessee

Calculation of Income Tax is illustrated with the help of following examples.

Use the above table for calculations.

Example 1: Calculate the amount of Income Tax at 5% of a person whose income is Rs.578,000 for the year.

Solution:

$$\text{Income of the person} = \text{Rs. } 578,000$$

The amount lies in Taxable income slab at Sr. # 2

i.e, 5% of the amount exceeding Rs. 400,000

$$\text{Taxable income} = 578,000 - 400,000$$

$$= \text{Rs. } 178,000$$

$$\therefore \text{Income Tax @ } 5\% = \frac{5}{100} \times 178,000$$

$$= \text{Rs. } 8,900$$

Example 2: The annual income of a person is Rs. 1,885,000. Calculate the amount of income tax if he paid Zakat Rs. 47,125.

Solution:

$$\text{Total income for the year} = \text{Rs. } 1,885,000$$

$$\text{Zakat} = \text{Rs. } 47,125$$

$$\text{Taxable income} = 1,885,000 - 47,125$$

$$= \text{Rs. } 1,837,875$$

This amount lies in Taxable income slab at Sr. # 6

i.e., Rate of tax is Rs.140000 + 17.5% of the amount exceeding Rs.1,800,000

$$\therefore \text{Income exceeding Rs. } 1,800,000 = 1,837,875 - 1,800,000$$

$$= \text{Rs. } 37,875$$

$$\text{Income tax @ } 17.5\% =$$

$$= \text{Rs. } 6628.12$$

$$\therefore \text{Total income tax} = 140,000 + 6628.12$$

$$= \text{Rs. } 146628.12$$

Example 3: The annual income of a person is *Rs.2,085,000*. He paid zakat *Rs.52,125*. Calculate his income tax on his income.

Solution:

$$\text{Total income of a year} = \text{Rs. } 2,085,000$$

$$\text{Zakat} = \text{Rs. } 52,125$$

$$\begin{aligned} \text{Taxable income} &= 2,085,000 - 52,125 \\ &= \text{Rs. } 2,032,875 \end{aligned}$$

This amount falls in the taxable income slab at Sr. # 6

i.e, *Rs.140,000 + 17.5% of the amount exceeding Rs.1,800,000*

$$\begin{aligned} \text{Amount exceeding Rs. } 1,800,000 &= 2,032,875 - 1,800,000 \\ &= \text{Rs. } 232,875 \end{aligned}$$

Income tax @ 17.5% of *Rs.232,875*,

$$= \text{Rs. } 40753$$

$$\begin{aligned} \therefore \text{Total income tax to be paid} &= 140,000 + 40753 \quad (\text{From slab at Sr. \# 6}) \\ &= \text{Rs. } 180,753 \end{aligned}$$

Example 4: A person earns *Rs.385,000* in a year. Calculate his income tax for the year.

Solution:

$$\text{Annual income} = \text{Rs.}385,000$$

Since this amount falls in the taxable income slab at Sr.# 1

i.e, 0% tax, it means he has to pay no income tax for the year.

EXERCISE 4.8

Solve the following questions by using the table of taxable income slabs.

1. The annual income of a person is *Rs.420,000*. Calculate his income tax when tax rate is 5%.
2. Calculate income tax of a person whose annual income is *Rs.1,085,000* and tax rate is 10%.

3. Annual salary of a person is *Rs. 1,475,000*. Calculate the annual income tax when tax rate is *12.5%*.
4. Calculate income tax of a person whose annual income is *Rs. 1,650,000*. The rate of tax is *15%*.
5. The annual income of a person is *Rs. 2,350,000*. Calculate his income tax when tax rate is *17.5%*.
6. Calculate income tax of a person whose annual income is *Rs. 2,875,000*. The rate of tax is *20%*.
7. A salaried person has his annual income *Rs. 3,375,000*. Calculate his income tax when tax rate is *22.5%*.
8. The annual income of an individual is *Rs. 3,987,500*. The tax rate is *25%*. Calculate the income tax of the person on his income.
9. A person earns *Rs. 12,735,000* from his business. Calculate his income tax on his income when tax rate is *30%*. If tax has been deducted tax at source amounting *Rs. 200,000*, how much money he has to pay now?

REVIEW EXERCISE 4

1. Four options are given against each statement. Encircle the correct one.
 - i. Proportion means:
 - (a) equality of two ratios
 - (b) equality of quantities
 - (c) inequality of two ratios
 - (d) inequality of quantities
 - ii. If the rate of conversion is $1\$ = \text{Rs. } 104$ then $\text{Rs. } 2600 = \$$:
 - (a) \$25
 - (b) \$250
 - (c) \$2500
 - (d) \$2.50
 - iii. An institution which accepts deposits, makes business loans and offers related services is called:
 - (a) bank
 - (b) leasing company
 - (c) ATM machine
 - (d) credit card company

- iv. ATM stands for:
 (a) Account Transfer Machine (b) Automated Teller Machine
 (c) Auto cash Transfer Machine (d) Account Teller Machine
- v. A person who buys life insurance from an insurance company is called:
 (a) insured (b) insurer
 (c) lesser (d) beneficiary
- vi. A person who deposits money in a bank is called:
 (a) account holder (b) visitor
 (c) borrower (d) drawer
- vii. The cost price of a toy car is *Rs.100*. If it is sold at 10% discount then the selling price of the toy car:
 (a) *Rs.90* (b) *Rs.110*
 (c) *Rs.80* (d) *Rs.120*
- viii. The relation between two or more proportions is called:
 (a) Compound Proportion (b) Direct Proportion
 (c) Inverse Proportion (d) Indirect Proportion
- ix. The rate of zakat is:
 (a) 10% (b) 2.5%
 (c) 25% (d) 0.25%
- x. Income tax at the rate of 4% on the income of *Rs. 200000* is:
 (a) *Rs.8000* (b) *Rs.80000*
 (c) *Rs.4000* (d) *Rs.2000*
2. Define the following:
- i. Proportion. ii. Compound Proportion iii. Partnership
 iv. Commercial Bank v. Negotiable instruments.
3. What is difference between cheque, Demand Draft and Pay order.
4. The price of a tricycle is *Rs.4000*. If 16% sales tax is charged, then calculate the amount of sales tax on 30 such tricycles.
5. A person has earned *Rs.8,000,000* in a year. The tax deducted at source is *Rs.150,000* and Zakat deducted *Rs.200,000* and tax rate 30%. Calculate his income tax for the year. (Use taxable income slabs)
6. Ammar insured his life for *Rs.1,000,000* at the rate of 5% per year. Find the amount of annual premium he has to pay.
7. A factory marked prices of the articles 25% above the cost price. The Cost Price of an article is *Rs.5000* and its selling price is *Rs.4500*. Find the discount % given to the customer.

SUMMARY

- The relationship between two or more proportions is known as compound proportion.
- A business in which two or more partners run the business and are responsible for profit or loss is called partnership.
- When a person dies, then the assets left by him is called inheritance.
- Banking is a business activity of accepting and safeguarding the money and earning a profit by lending out this money.
- The function of a bank which accepts deposits, provides loans and services to the clients is known as commercial banking.
- An account on the basis of profit and loss is known as PLS bank account.
- Current deposited account is usually opened by businessmen who have number of deposits and withdrawals regularly. It is a running account without any interest.
- PLS term deposit holder shares profit and loss on the rate determined by the bank after every six months.
- A foreign currency account is the account maintained in the currency other than Pakistani currency.
- A cheque is a written order that instructs a bank to pay the specific amount from a specified account to the holder of the cheque.
- Demand draft is a method used by individuals to make transfer payments from one bank account to another.
- Pay order is a document which instructs a bank to pay a certain amount to a third party and it is issued by the bank on the request of its customer.
- Online banking is the use of internet by the banks to assists their customers.
- An automated teller machine (ATM) is an electric device that allows a bank's customers to make cash and check their account balance.
- Credit card is a thin plastic card used to buy articles. Visa and Master cards are used worldwide for making payments. These are the names of global credit companies.
- Debit Card is a plastic payment card that provides card holder electronic access to his bank account at anytime and anywhere.
- The extra money which the bank pays for the use of our amount is called profit on the deposit.

- The extra money which a bank receives from a client on borrowed money is known as mark-up.
- Principal amount is the amount we borrow or deposit in the bank.
- The rate at which the bank gives share to its account holder is known as profit/mark-up rate.
- The time for which a particular amount is invested in a business is known as period
- Overdraft is a borrowing facility provided by a bank to account holder to withdraw some amount excess of his original balance.
- A lease is contractual agreement between the lessee (user) to pay the lessor (owner) for the use of an asset.
- Discount means to reduce the price of an article in its market price.
$$\text{Discount} = \text{Market price} - \text{Sale price}$$
- Insurance is a system of protecting or safeguarding against risk or injuries.
- Life insurance is an agreement between the policy owner and the insurance company for an agreed time period.
- Vehicle insurance provides a protection against risk to the vehicle.
- Income tax is imposed on the annual income of a person whose income exceeds a certain limit which is determined by the government.
- The income which is not subject to federal income tax is known as tax exempt income.
- Taxable income is the difference of annual income and exempted income i.e.,
$$\text{Taxable income} = \text{Annual income} - \text{Exempted income}$$

Unit - 5



Polynomials

After completion of this unit, the students will be able to:

- Recall constant, variable, literal and algebraic expression.
- Define
 - Polynomial
 - Degree of a polynomial
 - Coefficient of a polynomial
- Recognize polynomial in one, two and more variables.
- Recognize polynomials of various degrees (e.g. linear, quadratic, cubic and biquadratic polynomials).
- Add, subtract and multiply polynomials.
- Divide a polynomial by a linear polynomial.

5.1 ALGEBRAIC EXPRESSIONS:

An algebraic expression is made up of symbols and signs of algebra. Algebra helps us to make general formula because algebra is linked with arithmetic. For example, $x^2 + 2x + 1$ and $x \neq 0$ are algebraic expressions.



Algebra was introduced by Muslim Mathematician named Al Khwarazmi (780 - 850). He was also considered the "father of modern Algebra".

5.1.1 Recall Constant, Variable, Literal and Algebraic Expression

- **Constant**

A symbol that has a fixed numerical value is called a constant. For example in $5x + 7$, 5 and 7 are constants, whereas 7 is a constant term.

- **Variable:**

Variable is a symbol, usually a letter that is used to represent a quantity that may have an infinite number of values are also called unknowns. For example, in $x^2 + y + 3z$; x , y and z are variables.

- **Literal:**

The alphabets that are used to represent constants or coefficients are called literals. For example, in $ax^2 + bx + c$; a , b and c are literals whereas x is a variable.

- **Algebraic Expression:**

An expression which connects variables and constants by algebraic operations of addition, subtraction, multiplication and division is called an algebraic expression. A few algebraic expressions are given below:

(i) 14 (ii) $x + 2y$ (iii) $4x - y + 5$ (iv) $\frac{-2}{x} + y$ (v) $3y + 7z -$

5.2 POLYNOMIAL

5.2.1 Definitions

- **Polynomial**

A polynomial expression or simply a polynomial is an algebraic expression consisting of one or more terms in each of which the exponent of the variable is zero or a positive integer.

For example, 13, $-x$, $5x + 3y$, $x^2 - 3x + 1$ are all polynomials.

The following algebraic expressions are not polynomials.

$$x^{-2}, \frac{1}{y}, x^3 - x^{-3} + 3, x^2 + y^{-4} - 7 \text{ and } \frac{x}{y} + 5x$$

- **Degree of a Polynomial**

Degree of a polynomial is the highest power of a part (term) in a polynomial.

Degree of a term in a polynomial is the sum of the exponents on the variables in a single term. The degree of $2x^3y^4$ is 7 as $3 + 4 = 7$

- **Coefficient of a Variable**

In a term the number multiplied by the variable is called the coefficient of the variable as well as constant. In $4x + 6y$, 4 is coefficient of x , 6 is coefficient of y and both (4, 6) are constants.

5.2.2 Recognition of Polynomial in one, two and more Variables

(a) Polynomials in one Variable

Consider the following Polynomials:

(i) $x^4 + 4$ (ii) $x^2 - x + 1$ (iii) $y^3 + y^2 - y + 1$ (iv) $y^2 - y + 8$

In polynomials (i) and (ii) x is the variable and in polynomial (iii) and (iv) y is the variable. All these polynomials are polynomials in one variable.

(b) Polynomials in two Variables

Consider the following Polynomials:

(i) $x^2 + y + 2$ (ii) $x^2y + xy + 6$ (iii) $x^2z + xz + z$ (iv) $x^2z + 8$

In polynomials (i) and (ii) x, y are the variables. In polynomials (iii) and (iv) x, z are the variables. All these polynomials are in two variables.

(c) Polynomials in more Variables

Similarly $x^2yz + xy^2z + xy + 7$ is a polynomial in three variables x, y and z

5.2.3 Recognition of polynomials of various degrees

(e.g., linear, quadratic, cubic and biquadratic polynomials)

(a) Linear Polynomials:

Consider the following polynomials:

(i) $x + 2$ (ii) x (iii) $x + 2y$ (iv) $x + z$

In all these polynomials the degree of the variables x, y or z is one.

Such types of polynomials are linear polynomials.

(b) Quadratic Polynomials:

Let us write a few polynomials in which the highest exponent or sum of exponents is always 2.

(i) x^2 (ii) $x^2 - 3$ (iii) $xy + 1$

In the first two polynomials x is the variable and its degree is 2. In the third polynomial x, y are the variables and sum of their exponents is $1 + 1 = 2$. Its degree is also 2. Therefore polynomials of the type (i), (ii) and (iii) are quadratic polynomials.

(c) Cubic Polynomials:

Consider the following polynomials:

$$(i) \quad 5x^3 + x^2 - 4x + 1 \qquad (ii) \quad x^2y + xy^2 + y - 2$$

The degree of each one of the polynomial is 3. These polynomials are called cubic polynomials.

(d) Biquadratic Polynomials:

Let us take a few polynomials of 4 degrees.

$$(i) \quad x^4 + x^3y + x^2y^2 + y^3 - 1 \qquad (ii) \quad y^4 + y^3 - y^2 - y + 8$$

These are biquadratic polynomials.

EXERCISE 5.1

- Write the constant terms given in the expressions.
 (i) $3x + 4$ (ii) $2x^3 - 1$ (iii) $5y + 2x$ (iv) $7y^2 - 8$
- Write the variables taken in the equations.
 (i) $2x - 1 = 0$ (ii) $y + x = 3$
 (iii) $x^2 - x - 1 = 0$ (iv) $7y^2 - 2y + 3 = 0$
- Write the literals used in the equations.
 (i) $ax^2 + bx + c - y = 0$ (ii) $cx^2 + dx = 0$
 (iii) $bx + d = 0$ (iv) $ay^2 + d = 0$
- Separate the polynomial expressions and expressions that are not polynomials
 (i) $x^2 + x - 1$ (ii) $x^2y + xy^2 + 7$
 (iii) $x^{-2} + y + 7$ (iv) $\frac{x}{y^2} + 1 - \frac{y^2}{x}$
 (v) $x^3 - x^2 + y - 1$ (vi) $x^4 + x^2 + 5x + \frac{1}{2}$
- What constants are used in the following expressions?
 (i) $7x - 6y + 3z$ (ii) $5x^2 - 3$
 (iii) $8x^2 + 2y + 5$ (iv) $9y + 3x - 2z$
- Write the degree of the polynomials given below.
 (i) $x + 1$ (ii) $x^2 + x$
 (iii) $x^3 - xy + 1$ (iv) $x^2y^2 + x^3 + y^2 - 1$
- Separate the polynomials as linear, quadratic, cubic and biquadratic.
 (i) $3x + 1$ (ii) $x^2 - 2$ (iii) $y^2 - y$
 (iv) $x + y$ (v) $x^3 + x^2 - 2$ (vi) $x^4 + x^3 + x^2$
 (vii) $x^2y^2 + xy$ (viii) $x^2 + xy + 8$

5.3 OPERATIONS ON POLYNOMIALS

5.3.1 Addition, Subtraction and Multiplication of Polynomials

(i) Addition of algebraic expressions (Polynomials)

If $P(x)$ and $Q(x)$ are two polynomials, then their addition is represented as $P(x) + Q(x)$. In order to add two or more than two polynomials we first write the polynomials in descending or ascending order and like terms each in the form of columns. Finally, we add the coefficients of like terms.

Example 1: Add $3x^3 + 5x^2 - 4x$, $x^3 - 6 + 3x^2$ and $6 - x^2 - x$

Solution:

$$\begin{array}{r} 3x^3 + 5x^2 - 4x + 0 \\ x^3 + 3x^2 + 0x - 6 \\ 0x^3 - x^2 - x + 6 \\ \hline \text{Sum: } 4x^3 + 7x^2 - 5x \end{array}$$

(ii) Subtraction of polynomials

The subtraction of two polynomials P and Q is represented by $P - Q$ or $[P + (-Q)]$. If the sum of two polynomials is zero then P and Q are called additive inverse of each other.

$$\text{If } P = x + y \quad \text{and} \quad Q = -x - y,$$

$$\text{Then } P + Q = (x + y) + (-x - y) = 0$$

Like addition we write the polynomials in descending or ascending order and then change the sign of every term of the polynomial which is to be subtracted.

Example 2: Subtract $2x^3 - 4x^2 + 8 - x$ from $5x^4 + x - 3x^2 - 9$

Solution: Arrange the terms of the polynomials in descending order.

$$\begin{array}{r} 5x^4 + 0x^3 - 3x^2 + x - 9 \\ \pm 0x^4 \pm 2x^3 \mp 4x^2 \mp x \pm 8 \\ \hline \text{Difference: } 5x^4 - 2x^3 + x^2 + 2x - 17 \end{array}$$

(iii) Multiplication of polynomials

Multiplication of polynomials is explained through examples:

Example 3: Find the product of $4x^2$ and $5x^3$

$$\begin{aligned} \text{Solution: } (4x^2)(5x^3) &= 4 \times 5(x^2 \times x^3) && \text{(Associative Law)} \\ &= (20)(x^2 \times x^3) \\ &= 20x^{2+3} && \text{(Law of exponents)} \\ &= 20x^5 \end{aligned}$$

Example 4: Find the product of $3x^2 + 2x - 4$ and $5x^2 - 3x + 3$

Solution: Horizontal Method

$$\begin{aligned} & (3x^2 + 2x - 4)(5x^2 - 3x + 3) \\ &= 3x^2(5x^2 - 3x + 3) + 2x(5x^2 - 3x + 3) - 4(5x^2 - 3x + 3) \\ &= 15x^4 - 9x^3 + 9x^2 + 10x^3 - 6x^2 + 6x - 20x^2 + 12x - 12 \\ &= 15x^4 + (10 - 9)x^3 + (9 - 6 - 20)x^2 + (6 + 12)x - 12 \\ &= 15x^4 + x^3 - 17x^2 + 18x - 12 \end{aligned}$$

Example 5: Multiply $2x - 3$ with $5x + 6$

Solution: Vertical Method

$$\begin{array}{r} 5x + 6 \\ \times 2x - 3 \\ \hline 10x^2 + 12x \\ - 15x - 18 \\ \hline 10x^2 - 3x - 18 \end{array}$$

Note: The product of two polynomials is also a polynomial whose degree is equal to the sum of the degrees of the two polynomials.

5.3.2 Division of Polynomials

Division is the reverse process of multiplication.

The method of division of polynomials is explained through examples.

Example 6: Divide $(-8x^5)$ by $(-4x^3)$

Solution:

$$\begin{aligned} (-8x^5) \div (-4x^3) &= (-8x^5) \times \frac{1}{-4x^3} \\ &= 2x^{5-3} \\ &= 2x^2 \end{aligned}$$

Example 7: Divide $x^3 - 2x + 4$ by $x + 2$

Solution:

$$\begin{array}{r} x^2 - 2x + 2 \\ x + 2 \overline{) x^3 + 0x^2 - 2x + 4} \\ \underline{\pm x^3 \pm 2x^2} \\ -2x^2 - 2x \\ \underline{\mp 2x^2 \mp 4x} \\ 2x + 4 \\ \underline{\pm 2x \pm 4} \\ 0 \end{array}$$

Note: If a polynomial is exactly divisible by another polynomial then the remainder is zero.

EXERCISE 5.2

- Add:
 - $1 + 2x + 3x^2, 3x - 4 - 2x^2, x^2 - 5x + 4$
 - $a^3 + 2a^2 - 6a + 7, a^3 + 2a + 5, 2a^3 + 2a - a^2 - 8$
 - $a^3 - 2a^2b + b^3, 4a^3 + 2ab^2 + 6a^2b, 2b^3 - 5a^3 - 4a^2b$
- Subtract P from Q when,
 - $P = 3x^4 + 5x^3 + 2x^2 - x$; $Q = 4x^4 + 2x^2 + x^3 - x + 1$
 - $P = 2x + 3y - 4z - 1$; $Q = 2y + 3x - 4z + 1$
 - $P = a^3 + 2a^2b + 3ab^2 + b^3$; $Q = a^3 - 3a^2b + 3ab^2 - b^3$
- Find the value of $x - 2y + 3z$ where $x = 2a^2 - a^3 + 3a + 4$,
 $y = 2a^3 - 3a^2 + 2 - 2a$ and $z = a^4 + 3a^3 - 6 - 5a^2$
- The sum of two polynomials is $x^2 + 2x - y^2$. If one polynomial is $x^2 - 2xy + 3$, then find the other polynomial.
- Subtract $4x + 6 - 2x^2$ from the sum of $x^3 + x^2 - 2x$ and $2x^3 + 3x - 7$
- Find the product of the following polynomials.
 - $(x + 3)(x^2 - 3x + 9)$ (ii) $(3x^2 - 7x + 5)(4x^2 - 2x + 1)$
 - $(a + b + c)(a^2 + b^2 + c^2 - ab - bc - ca)$
- If $P = x^2 - yz$, $Q = y^2 - xz$ and $R = z^2 - xy$, then find PQ , QR , PR and PQR .
- Simplify:
 - $(x^2 + x - 6) \div (x - 2)$ (ii) $(x^3 - 19x - 30) \div (x + 3)$
 - $(x^5 - y^5) \div (x - y)$ (iv) $(x^3 + x^2 - 14x - 24) \div (x + 2)$
 - $(16a^5 + 4a^3 - 4a^2 + 3a - 1) \div (4a^2 - 2a + 1)$
 - $(x^4 - 3x^2y^2 + y^4) \div (x^2 + xy - y^2)$
- What should be added to $4x^3 - 10x^2 + 12x + 6$ so that it becomes exactly divisible by $2x + 1$?
- The product of two polynomials $6y^3 - 11y^2 + 6y - 1$. If one polynomial is $3y^2 - 4y + 1$, then find the other polynomial.
- For what value of p the polynomial $3x^3 - 7x^2 - 9x + p$ becomes exactly divisible by $x - 3$?

REVIEW EXERCISE 5

1. Four options are given against each statement. Encircle the correct one.
- $4x + 2y + 3z$ is an algebraic:
 - expression
 - equation
 - inequality
 - symbol
 - The alphabet which can assume different values is called
 - constant
 - variable
 - term
 - number
 - In $2x - 3y + 4z$, there are variables:
 - 2
 - 3
 - 4
 - 5
 - To represent variable we use:
 - Constants
 - Numbers
 - Alphabets
 - Literals
 - An algebraic expression can contain:
 - numbers, variables and operations
 - number and operations
 - variables only
 - operations only
 - $2x^{-2}$ is:
 - a polynomial
 - not a polynomial
 - a constant term
 - an inequality
 - In $3x^2 + 2x - 1$, the degree of the polynomial is:
 - 1
 - 2
 - 3
 - 4
 - In a polynomial the number multiplied with the variable is called a:
 - number
 - coefficient
 - index
 - constant
 - Polynomial $3y^2$ is:
 - linear
 - quadratic
 - cubic
 - biquadratic
 - Biquadratic algebraic expression is a polynomial of degree:
 - one
 - two
 - three
 - four
2. Indicate polynomial and their degree in the following table.

Sr. #	Algebraic Expression	Polynomial	Degree of polynomial
i.	$2.3 + 1.2x$		
ii.	$k^2 + 5k^{-1} + 6$		
iii.	-9		
iv.	$2c^4 + 5b + \frac{6}{7}$		

3. Find the sum of the following polynomials.

i. $2a + 3b + c$, $3a - b - c$, $4b + 5c$, $-2a + 3c$ and $-b + c$

ii. $9z + 3y^2 - 5x^3$, $-z - 2y^2 - 4x^3$, $z - x^3$ and $-2z + 3y^2$

4. Solve:

i. $(-2x^2 + 5y^2 - 3z^2) - (5x^2 - 3y^2 - 6z^2)$

ii. $(6x^3 + x^2 - 26) - (9 + 3x^2 - 5x^3)$

iii. $(y^2 - 5)(-y^2 + 5)$

iv. $(3a + 2b)(4a^2 - 7b + 5)$

v. $(x^4 + x - 2) \div (x - 1)$

SUMMARY

- An expression which connects variables and constants by algebraic operations of addition subtraction, multiplication and division is called an algebraic expression.
- Constants are algebraic symbols that have a fixed value and do not change.
- A symbol in algebra which can assume different numerical values (numbers) is called a variable.
- A literal is a value that is expressed as itself. For example, the number 25 or the word "speed" are both literals.
- An algebraic expression which has finite number of terms and the exponents of variables are whole numbers, is called polynomial.
- A polynomial is either zero or can be written as the sum of a finite number of non-zero terms.
- In a polynomial coefficient is a number or symbol multiplied with a variable in an algebraic term.
- The polynomials of degree one are called linear polynomials.
- The polynomials of degree two are called quadratic polynomials.
- The polynomials of degree three are called cubic polynomials.
- The polynomials of degree four are called biquadratic polynomial.

After completion of this unit, the students will be able to:

- Recall the formulas:
 - $(a + b)^2 = a^2 + 2ab + b^2$
 - $(a - b)^2 = a^2 - 2ab + b^2$
- $a^2 - b^2 = (a - b)(a + b)$ and apply them to solve problems like:
- Evaluate $(102)^2$, $(1.02)^2$, $(98)^2$ and $(0.98)^2$.
- Find $x^2 + \frac{1}{x^2}$ and $x^4 + \frac{1}{x^4}$ when the value of $x \pm \frac{1}{x}$ is given.

Factorize expressions of the following types:

- $Ka + kb + kc$
- $ac + ad + bc + bd$
- $a^2 \pm 2ab + b^2$
- $a^2 - b^2$
- $a^2 + 2ab + b^2 - c^2$
- Recognize the formulas:
 - $(a + b)^3 = a^3 + 3a^2b + 3ab^2 + b^3$
 - $(a - b)^3 = a^3 - 3a^2b + 3ab^2 - b^3$ and apply them to solve the problems like this
 - $x^3 + \frac{1}{x^3}$ and $x^3 - \frac{1}{x^3}$ when the value of $x \pm \frac{1}{x}$ is given.
- Recognize simultaneous linear equations in one and two variables.
- Give the concept of formation of linear equation in two variables.
- Know that:
 - A single linear equation in two unknown is satisfied by many pair of values as required.
 - Two linear equations in two unknown have only one solution (i.e. one pair of values).
- Solve simultaneous linear equations using
 - Method of equating the coefficients
 - Method of elimination by substitution
 - Method of cross multiplication
 - Solve real life problems involving two simultaneous linear equations in two variables.
- Eliminate a variable from two equations by:
 - Substitution
 - Application of formulas

6.1 BASIC ALGEBRAIC FORMULAS

- $(a + b)^2 = a^2 + 2ab + b^2$

Example 1: Evaluate $(107)^2$ by using formula

Solution: $(107)^2 = (100 + 7)^2$
 $= (100)^2 + 2(100 \times 7) + (7)^2$
 $= 10000 + 1400 + 49$
 $= 11449$

- $(a - b)^2 = a^2 - 2ab + b^2$

Example 2: Using the formula, evaluate $(87)^2$

Solution: $(87)^2 = (90 - 3)^2$
 $= (90)^2 - 2(90 \times 3) + (3)^2$
 $= 8100 - 540 + 9$
 $= 7569$

- $a^2 - b^2 = (a + b)(a - b)$

Example 3: Using the formula, evaluate 107×93

Solution: $107 \times 93 = (100 + 7)(100 - 7)$
 $= (100)^2 - (7)^2$
 $= 10000 - 49$
 $= 9951$

Example 4: Find the value of $x^2 + \frac{1}{x^2}$ and $x^4 + \frac{1}{x^4}$ when $x - \frac{1}{x} = 2$

Solution: Here, $x - \frac{1}{x} = 2$

$$\left(x - \frac{1}{x}\right)^2 = (2)^2 \quad (\text{Taking square of both the sides})$$

or $x^2 - 2(x)\left(\frac{1}{x}\right) + \left(\frac{1}{x}\right)^2 = 4$

or $x^2 - 2 + \frac{1}{x^2} = 4$

or $x^2 + \frac{1}{x^2} = 4 + 2$

or $x^2 + \frac{1}{x^2} = 6$

or $\left(x^2 + \frac{1}{x^2}\right)^2 = (6)^2 \quad (\text{Again taking square of both the sides})$

$$\text{or } (x^2)^2 + 2(x^2) + \quad = 36$$

$$\text{or } x^4 + 2 + \frac{1}{x^4} = 36$$

$$\text{or } x^4 + \frac{1}{x^4} = 36 - 2$$

$$x^4 + \frac{1}{x^4} = 34$$

EXERCISE 6.1

Solve the following questions by using formulas:

- Evaluate square of each of the following:
 (i) 53 (ii) 77 (iii) 509 (iv) 1006
- Evaluate each of the following:
 (i) $(57)^2$ (ii) $(95)^2$ (iii) $(598)^2$ (iv) $(1997)^2$
- Evaluate:
 (i) 46×54 (ii) 197×203 (iii) 999×1001 (iv) 0.96×1.04
- (i) Find the value of $x^2 + \frac{1}{x^2}$, when $x + \frac{1}{x} = 7$
 (ii) Find the value of $x^2 + \frac{1}{x^2}$, when $x - \frac{1}{x} = 3$
 (iii) Find the value of $x^4 + \frac{1}{x^4}$, when $x - \frac{1}{x} = 1$

6.2 FACTORIZATION

Factors of an expression are the expressions whose product is the given expression.

The process of expressing the given expressions as a product of its factors is called 'Factorization' or 'Factorizing'.

(i) Type $Ka + Kb + Kc$:

Example 1: Factorize $2x - 4y + 6z$

Solution: $2x - 4y + 6z$
 $= 2(x - 2y + 3z)$ "2" is a factor common to each term

Example 2: Factorize $x^2 - xy + xz$

Solution: $x^2 - xy + xz$
 $= x(x - y + z)$

Example 3: Factorize $3x^2 - 6xy$

Solution: $3x^2 - 6xy$
 $= 3x(x - 2y)$

EXERCISE 6.2

Factorize the following:

- | | | | |
|-----|------------------------------|-----|-------------------------------|
| 1. | $3x - 9y$ | 2. | $xy + xz$ |
| 3. | $6ab - 14ac$ | 4. | $3m^3np - 6m^2n$ |
| 5. | $30x^3 - 45xy$ | 6. | $17x^2y^2 - 51$ |
| 7. | $4x^3 + 3x^2 + 2x$ | 8. | $2p^2 - 4p^3 + 8p$ |
| 9. | $x^3y - x^2y + xy^2$ | 10. | $7x^4 - 14x^2y + 21xy^3$ |
| 11. | $x^2y^2z^2 - xyz^2 + xyz$ | 12. | $4x^3y^2 - 8xy + 4xy^3$ |
| 13. | $xy^4 - 3xy^3 - 6xy^2$ | 14. | $x^2y^2z + x^2yz^2 + xy^2z^2$ |
| 15. | $77x^2y - 33xy^2 - 55x^2y^2$ | 16. | $5x^5 + 10x^4 + 15x^3$ |

(ii) Type $ac + ad + bc + bd$:

Consider the following examples for such cases.

Example 4: Factorize: $3x + cx + 3c + c^2$

Solution:

$$\begin{aligned} & 3x + cx + 3c + c^2 \\ &= (3x + cx) + (3c + c^2) \\ &= x(3 + c) + c(3 + c) \\ &= (3 + c)(x + c) \end{aligned}$$

Example 5: Factorize: $2x^2y - 2xy + 4y^2x - 4y^2$

Solution:

$$\begin{aligned} & 2x^2y - 2xy + 4y^2x - 4y^2 \\ &= 2y(x^2 - x + 2yx - 2y) \\ &= 2y[x(x - 1) + 2y(x - 1)] \\ &= 2y(x - 1)(x + 2y) \end{aligned}$$

EXERCISE 6.3

Factorize the following:

- | | | | |
|-----|-------------------------------|-----|-------------------------|
| 1. | $ax - by + bx - ay$ | 2. | $2ab - 6bc - a + 3c$ |
| 3. | $x^2 + 2x - 3x - 6$ | 4. | $x^2 + 5x - 2x - 10$ |
| 5. | $x^2 - 7x + 2x - 14$ | 6. | $x^2 + 3x - 4x - 12$ |
| 7. | $y^2 - 9y + 3y - 27$ | 8. | $x^2 - 8x - 4x + 32$ |
| 9. | $x^2 - 7x - 5x + 35$ | 10. | $x^2 - 13x - 2x + 26$ |
| 11. | $a(x - y) - b(x - y)$ | 12. | $y(y - a) - b(y - a)$ |
| 13. | $a^2(pq - rs) + b^2(pq - rs)$ | 14. | $ab(x + y) + cd(x + y)$ |

(iii) Type $a^2 \pm 2ab + b^2$:

Consider the following examples for such cases.

Example 6: Factorize: $9a^2 + 30ab + 25b^2$

Solution: $9a^2 + 30ab + 25b^2$
 $= (3a)^2 + 2(3a \times 5b) + (5b)^2$
 $= (3a + 5b)^2$

Example 7: Factorize: $16x^2 - 64x + 64$

Solution: $16x^2 - 64x + 64$
 $= 16(x^2 - 4x + 4)$
 $= 16[(x)^2 - 2(2)(x) + (2)^2]$
 $= 16(x - 2)^2$

Example 8: Factorize: $8x^3y + 8x^2y^2 + 2xy^3$

Solution: $8x^3y + 8x^2y^2 + 2xy^3$
 $= 2xy(4x^2 + 4xy + y^2)$
 $= 2xy[(2x)^2 + 2(2x)(y) + (y)^2]$
 $= 2xy(2x + y)^2$

EXERCISE 6.4

Factorize:

1. $x^2 + 14x + 49$

3. $16 + 24a + 9a^2$

5. $7a^4 + 84a^2 + 252$

7. $x^2 - 34x + 289$

9. $x^2 - 18xy + 81y^2$

11. $2a^2 - 64a + 512$

13. $4x^4 + 20x^3yz + 25x^2y^2z^2$

15. $\frac{49}{64}x^2 - 2xy + \frac{64}{49}y^2$

17. $16x^6 - 16x^5 + 4x^4$

2. $9a^2 + 12ab + 4b^2$

4. $25x^2 + 80xy + 64y^2$

6. $4a^2 + 120a + 900$

8. $49x^2 - 84x + 36$

10. $a^4 - 26a^2 + 169$

12. $1 - 6a^2b^2c + 9a^4b^4c^2$

14. $\frac{9}{16}x^2 + xy + \frac{4}{9}y^2$

16. $\frac{a^2}{b^2}x^2 - \frac{2ac}{bd}xy +$

18. $a^4b^4x^2 - 2a^2b^2c^2d^2xy + c^4d^4y^2$

(iv) Type $a^2 - b^2$:

Consider the following examples for such cases.

Example 9: Factorize: $25x^2 - 64$

Solution: $25x^2 - 64$
 $= (5x)^2 - (8)^2$
 $= (5x + 8)(5x - 8)$

Example 10: Factorize: $16y^2b - 81bx^2$

Solution: $16y^2b - 81bx^2$
 $= b(16y^2 - 81x^2)$
 $= b[(4y)^2 - (9x)^2]$
 $= b(4y + 9x)(4y - 9x)$

Example 11: Factorize: $(3x - 5y)^2 - 49z^2$

Solution: $(3x - 5y)^2 - 49z^2$
 $= (3x - 5y)^2 - (7z)^2$
 $= (3x - 5y + 7z)(3x - 5y - 7z)$

Example 12: Factorize: $36(x + y)^2 - 25(x - y)^2$

Solution: $36(x + y)^2 - 25(x - y)^2$
 $= [6(x + y)]^2 - [5(x - y)]^2$
 $= [6(x + y) + 5(x - y)][6(x + y) - 5(x - y)]$
 $= (11x + y)(x + 11y)$

Example 13: Use formula to evaluate: $(677)^2 - (323)^2$

Solution: $(677)^2 - (323)^2$
 $= (677 + 323)(677 - 323)$
 $= 1000 \times 354$
 $= 354000$

Example 14: Simplify: $\frac{0.987 \times 0.987 - 0.643 \times 0.643}{0.987 + 0.643}$

Solution: $\frac{0.987 \times 0.987 - 0.643 \times 0.643}{0.987 + 0.643}$
 $= \frac{(0.987)^2 - (0.643)^2}{0.987 + 0.643}$
 $= \frac{(0.987 + 0.643)(0.987 - 0.643)}{0.987 + 0.643}$
 $= 0.987 - 0.643$
 $= 0.344$

EXERCISE 6.5

Factorize the following expressions:

- | | |
|--------------------------|-----------------------|
| 1. $9 - x^2$ | 2. $-6 + 6y^2$ |
| 3. $16x^2y^2 - 25a^2b^2$ | 4. $x^3y - xy^3$ |
| 5. $16a^2 - 400b^2$ | 6. $a^2b^3 - 64a^2b$ |
| 7. $7xy^2 - 343x$ | 8. $5x^3 - 45x$ |
| 9. $11(a + b)^2 - 99c^2$ | 10. $75 - 3(a - b)^2$ |

11. $-\frac{36}{25}y^2$

12. $25 - 16$

13. $16(a+b)^2 - 49(a-b)^2$

14. $36 - 64$

Evaluate the following:

15. $(371)^2 - (129)^2$

16. $(674.17)^2 - (325.83)^2$

17. $\frac{(0.567)^2 - (0.433)^2}{0.567 - 0.433}$

18. $\frac{(0.409)^2 - (0.391)^2}{0.409 - 0.391}$

(v) Type $a^2 \pm 2ab + b^2 - c^2$:

This type can be explained through the following examples.

Example 15: $a^2 - 2ab + b^2 - 4c^2$

Solution:

$$\begin{aligned} & (a^2 - 2ab + b^2) - 4c^2 \\ &= (a-b)^2 - (2c)^2 \\ &= (a-b-2c)(a-b+2c) \end{aligned}$$

Example 16: $4a^2 + 4ab + b^2 - 9c^2$

Solution:

$$\begin{aligned} & 4a^2 + 4ab + b^2 - 9c^2 \\ &= (2a)^2 + 2(2a)(b) + (b)^2 - 9c^2 \\ &= (2a+b)^2 - (3c)^2 \\ &= (2a+b-3c)(2a+b+3c) \end{aligned}$$

EXERCISE 6.6

Factorize:

1. $a^2 + 2ab + b^2 - c^2$

2. $a^2 + 6ab + 9b^2 - 16c^2$

3. $a^2 + b^2 + 2ab - 9a^2b^2$

4. $x^2 - 4xy + 4y^2 - 9x^2y^2$

5. $9a^2 - 6ab + b^2 - 16c^2$

6.3 MANIPULATION OF ALGEBRAIC EXPRESSION• **Formula** $(a+b)^3 = a^3 + 3ab(a+b) + b^3$ **Example 1:** Expand $(3a+4b)^3$ **Solution:**

$$\begin{aligned} & (3a+4b)^3 \\ &= (3a)^3 + 3(3a)(4b)(3a+4b) + (4b)^3 \\ &= 27a^3 + 36ab(3a+4b) + 64b^3 \\ &= 27a^3 + 108a^2b + 144ab^2 + 64b^3 \end{aligned}$$

- **Formula** $(a - b)^3 = a^3 - 3ab(a - b) - b^3$

This type can be explained with the following examples.

Example 2: Expand $(2a - 3b)^3$

Solution:

$$\begin{aligned} & (2a - 3b)^3 \\ &= (2a)^3 - 3(2a)(3b)(2a - 3b) - (3b)^3 \\ &= 8a^3 - 18ab(2a - 3b) - 27b^3 \\ &= 8a^3 - 36a^2b + 54ab^2 - 27b^3 \end{aligned}$$

Example 3: If $x + \frac{1}{x} = 5$, then find the value of $x^3 + \frac{1}{x^3}$

Solution: We have, $x + \frac{1}{x} = 5$

$$= (x)^3 + 3(x) \quad \times \quad +$$

$$= x^3 + 3 \quad + \frac{1}{x^3}$$

=

$$(5)^3 = x^3 + \frac{1}{x^3} + 3(5) \quad = 5$$

$$125 = x^3 + \frac{1}{x^3} + 15$$

$$\Rightarrow \quad x^3 + \frac{1}{x^3} = 125 - 15$$

Thus, $x^3 + \frac{1}{x^3} = 110$

EXERCISE 6.7

1. Find the cube of the following:

(i) $x + 4$

(ii) $2m + 1$

(iii) $a - 2b$

(iv) $5x - 1$

(v) $2a + b$

(vi) $3x + 10$

(vii) $2m + 3n$

(viii) $4 - 3a$

(ix) $3x + 3y$

(x) $7 + 2b$

(xi) $4x - 2y$

(xii) $5m + 4n$

2. If $x + \frac{1}{x} = 8$, then find the value of $x^3 + \frac{1}{x^3}$
3. If $x - \frac{1}{x} = 3$, then find the value of $x^3 - \frac{1}{x^3}$
4. If $x + \frac{1}{x} = 7$, then find the value of $x^3 + \frac{1}{x^3}$
5. If $x - \frac{1}{x} = 2$, then find the value of $x^3 - \frac{1}{x^3}$
6. Find the cube of the following by using formula.
 - (i) 13
 - (ii) 103
 - (iii) 0.99

6.4 SIMULTANEOUS LINEAR EQUATIONS

If two or more linear equations consisting of same set of variables are satisfied simultaneously by the same values of the variables, then these equations are called simultaneous linear equations.

6.4.1 Recognizing Simultaneous Linear Equations in One and Two Variables

We know that a linear equation is an algebraic equation in which each term is either a constant or a variable or the product of a constant or a variable. The standard form of linear equation consisting of one variable is:

$$ax + b, \quad \forall a, b \in R$$

Similarly, a linear equation in two variables is of the form $ax + by = c$, where a , b and c are constants. Two linear equations considered together, form a system of linear equations. For example

$x + y = 2$ and $x - y = 1$ is a system of two linear equations with two variables x and y . This system of two linear equations is known as the simplest form of linear system which can be written in general form as:

$$\begin{aligned} a_1x + b_1y &= c_1 \\ a_2x + b_2y &= c_2 \end{aligned}$$

6.4.2 Concept of Formation of Linear Equation in Two Variables

Statements involving two unknowns can be written in algebraic form as explained in the following examples.

Example 1: Write an equation for each statement.

- (i) The price of a book and 3 pencils is 90 rupees.
 (ii) Sum of two numbers is 5.
 (iii) The weight of Iram is half of the weight of Ali.

Solution:

(i) Price of a book and 3 pencils = Rs.90
 Let the price of one book = x
 The price of one pencil = y
 \therefore The equation can be written as $x + 3y = 90$

(ii) Sum of two numbers = 5
 Let the first number = x
 The second number = y
 \therefore The equation can be written as $x + y = 5$

(iii) Let the weight of Iram = x
 The weight of Ali = y
 \therefore The equation can be written as $x = \frac{y}{2}$

6.4.3 Solution of a Linear Equation in Two Unknowns

The solution of linear equation $ax + by = c$ in two variables “ x ” and “ y ” is an ordered pair of “ x ” and “ y ” that satisfies $ax + by = c$. Since a linear equation represents a straight line, hence an equation may have so many solutions.

Example 2: Find four solutions for the equation $3x + y = 2$.

Solution: $3x + y = 2$

Put the value of $x = 0$

$$3(0) + y = 2$$

$$\Rightarrow 0 + y = 2$$

$$\Rightarrow y = 2$$

Put the value of $x = 2$

$$3(2) + y = 2$$

$$\Rightarrow 6 + y = 2$$

$$\Rightarrow y = 2 - 6$$

$$\Rightarrow y = -4$$

Put the value of $x = 1$

$$3(1) + y = 2$$

$$\Rightarrow 3 + y = 2$$

$$\Rightarrow y = 2 - 3 = -1$$

Put the value of $x = 3$

$$3(3) + y = 2$$

$$\Rightarrow 9 + y = 2$$

$$\Rightarrow y = 2 - 9$$

$$\Rightarrow y = -7$$

Thus, the solutions of the given equation are infinite $(0, 2)$, $(1, -1)$, $(2, -4)$, $(3, -7)$,

• Solution of two Linear Equations in two Unknowns

A pair of linear equations in two variables is said to form a system of simultaneous linear equations. A pair of values of x and y which satisfy each one of the given equations in x and y is called solution of the system of simultaneous linear equations.

For example, two linear equations $x + y = 5$ and $x - y = 3$ have solution $x = 4$ and $y = 1$ i.e.,

$$\begin{array}{l|l} x + y = 5 & x - y = 3 \\ \text{L.H.S} = x + y & \text{L.H.S} = x - y \\ = (4) + (1) & = (4) - (1) \\ = 5 = \text{R.H.S} & = 3 = \text{R.H.S} \end{array}$$

Thus, $x = 4$ and $y = 1$ is a solution of the given equations.

EXERCISE 6.8

1. Write equations for the following statements.
 - (i) The difference between father's age and daughter's age is 26 years.
 - (ii) The price of 6 biscuits is equal to the price of one chocolate.
 - (iii) If a number is added to three times of another number, the sum is 25
 - (iv) The division of sum of two numbers by their difference is equal to 1 (2^{nd} number is less than 1^{st})
 - (v) Twice of any age increased by 7 years becomes y years.
2. Find two solutions for the equation $2x + y = 3$
3. Find three solutions for the equations $x + y = 2$
4. Find four solutions for the equations $y = 2x$
5. Is $(1, 2)$ a solution set of $x + y = 3$ and $2x + 7y = 16$?
6. Which one of $(3, 1)$ and $(0, 3)$ is a solution of $2x + 5y = 15$ and $y - x = 3$?

6.5 SOLUTION OF SIMULTANEOUS LINEAR EQUATIONS

The solution of simultaneous linear equations means finding values for the variables that make them true sentences. Let us learn how to find the solution of simultaneous linear equations.

6.5.1 Solve Simultaneous Linear Equations

There are many methods of solving simultaneous linear equations but here we shall confine ourselves to the following three methods.

- Method of equating the coefficients.
- Method of elimination by substitution.
- Method of cross Multiplication.

• Method of Equating the Coefficients

Example 1: Find the solution with the method of equating the coefficients.

$$\begin{array}{l} 9x + 8y = 1 \\ 5x - y = 6 \end{array}$$

Solution:

$$\begin{array}{ll} 9x + 8y = 1 & \dots\dots\dots (i) \\ 5x - y = 6 & \dots\dots\dots (ii) \end{array}$$

Step 1: Convert the given equation into an equivalent equation in such a way that the coefficient of one variable must be same. Multiply both sides of equation (ii) by 8, we have

$$\begin{aligned} 8(5x - y) &= 8(6) \\ 40x - 8y &= 48 \quad \dots\dots\dots \text{(iii)} \end{aligned}$$

Step 2: Add equations (i) and (iii) to find the value of one variable.

$$\begin{array}{r} 9x + 8y = 1 \\ 40x - 8y = 48 \\ \hline 49x \quad = 49 \\ \hline x = \frac{49}{49} = 1 \end{array}$$

Step 3: Put the value of “x” in equation (i) or (ii) to find the value of “y”.

$$\begin{aligned} 5x - y &= 6 \quad \dots\dots\dots \text{(ii)} \\ 5(1) - y &= 6 \\ 5 - y &= 6 \\ y = 5 - 6 &= -1 \end{aligned}$$

Thus, $x = 1$ and $y = -1$ is the required solution.

Step 4: Check the answer by placing the values of “x” and “y” in any equation.

$$\begin{aligned} 9x + 8y &= 1 \\ \text{L.H.S} &= 9x + 8y \\ &= 9(1) + 8(-1) \\ &= 9 - 8 = 1 = \text{R.H.S} \end{aligned}$$

• Method of Elimination by Substitution

Example 2: Find the solution set with the method of elimination by substitution.

$$\begin{aligned} 3x + 5y &= 5 \\ x + 2y &= 1 \end{aligned}$$

Solution:

$$\begin{aligned} 3x + 5y &= 5 \quad \dots\dots\dots \text{(i)} \\ x + 2y &= 1 \quad \dots\dots\dots \text{(ii)} \end{aligned}$$

Step 1: Find the value of “x” or “y” from any of the given equations.

From equation (ii)

$$x + 2y = 1 \Rightarrow x = 1 - 2y \quad \dots\dots\dots \text{(iii)}$$

Step 2: Substitute the value of “x” in equation (i)

$$\begin{aligned} &3x + 5y = 5 \\ \Rightarrow &3(1 - 2y) + 5y = 5 \\ \Rightarrow &3 - 6y + 5y = 5 \\ \Rightarrow &3 - y = 5 \\ \Rightarrow &y = 3 - 5 = -2 \end{aligned}$$

Step 3: Put the value of “y” in equation (iii) to find the value of “x”.

$$x = 1 - 2y \quad (\text{from (iii)})$$

$$x = 1 - 2(-2) = 1 + 4$$

$$x = 5$$

Hence, $x = 5$ and $y = -2$ is the required solution.

Step 4: Check the answer by putting the values in any equation i.e., in (i) or (ii).

$$3x + 5y = 5 \quad \text{from (i)}$$

$$\text{L.H.S} = 3(5) + 5(-2)$$

$$= 15 - 10$$

$$= 5 = \text{R.H.S}$$

Also check by putting the values in equation (ii) $x + 2y = 1$

$$\text{L.H.S} = (5) + 2(-2)$$

$$= 5 - 4$$

$$= 1 = \text{R.H.S}$$

• Method of cross Multiplication

Let the two equations be

$$a_1x + b_1y + c_1 = 0 \quad \dots\dots\dots \text{(i)}$$

$$a_2x + b_2y + c_2 = 0 \quad \dots\dots\dots \text{(ii)}$$

Multiplying (i) by b_2 and (ii) by b_1 , we have

$$a_1b_2x + b_1b_2y + b_2c_1 = 0 \quad \dots\dots\dots \text{(iii)}$$

$$a_2b_1x + b_1b_2y + b_1c_2 = 0 \quad \dots\dots\dots \text{(iv)}$$

Subtracting (iii) from (iv)

$$a_2b_1x + b_1b_2y + b_1c_2 = 0$$

$$\pm a_1b_2x \pm b_1b_2y \pm b_2c_1 = 0$$

$$\hline a_2b_1x - a_1b_2x + b_1c_2 - b_2c_1 = 0$$

$$\Rightarrow x(a_2b_1 - a_1b_2) = b_2c_1 - b_1c_2 \quad \Rightarrow \quad \frac{x(a_2b_1 - a_1b_2)}{1} = \frac{b_2c_1 - b_1c_2}{1}$$

$$\Rightarrow \quad \quad \quad \Rightarrow$$

Now, multiplying (i) by a_2 and (ii) by a_1 , we have

$$a_1a_2x + a_2b_1y + a_2c_1 = 0 \quad \dots\dots\dots \text{(v)}$$

$$a_1a_2x + a_1b_2y + a_1c_2 = 0 \quad \dots\dots\dots \text{(vi)}$$

Subtracting (v) from (vi)

$$a_1a_2x + a_1b_2y + a_1c_2 = 0$$

$$\pm a_1a_2x \pm a_2b_1y \pm a_2c_1 = 0$$

$$\hline a_1b_2y - a_2b_1y + a_1c_2 - a_2c_1 = 0$$

$$\Rightarrow y(a_1b_2 - a_2b_1) = a_2c_1 - a_1c_2$$

$$\Rightarrow y = \frac{a_2c_1 - a_1c_2}{a_1b_2 - a_2b_1}$$

\Rightarrow

The following diagram helps in remembering and writing the above solution.

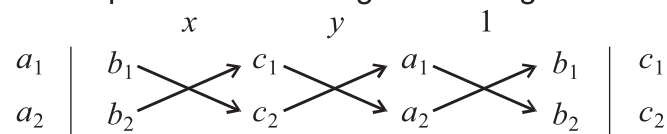

The arrows between two numbers indicate that they are to be multiplied and the second product is to be subtracted from the first.

Example 3: Find the solution set with the method of cross multiplication.

$$\begin{aligned} 2x + y &= 5 \\ 3x - 4y &= 2 \end{aligned}$$

Solution: Rewrite the given equation to have zero on the right hand side.

$$\begin{aligned} 2x + y &= 5 && \dots\dots\dots (i) \\ 3x - 4y &= 2 && \dots\dots\dots (ii) \\ 2x + y - 5 &= 0 \\ 3x - 4y - 2 &= 0 \end{aligned}$$

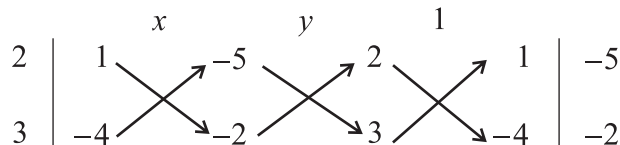

Now, we can immediately write down the solution.

$$\frac{x}{(1)(-2) - (-4)(-5)} = \frac{y}{(-5)(3) - (-2)(2)} = \frac{1}{(2)(-4) - (3)(1)}$$

$$\frac{x}{-2 - 20} = \frac{y}{-15 + 4} = \frac{1}{-8 - 3}$$

$$\Rightarrow \frac{x}{-22} = \frac{y}{-11} = \frac{1}{-11}$$

$$\Rightarrow x = \frac{-22}{-11} = 2 \text{ and } y = \frac{-11}{-11} = 1$$

Thus, $x = 2$ and $y = 1$ is the required solution.

Step 4: Check the answer by putting the values of $x = 2$ and $y = 1$ in the equation

$$\begin{aligned} 2x + y &= 5 \text{ from (i)} \\ \text{L.H.S} &= 2(2) + (1) \\ &= 4 + 1 = 5 = \text{R.H.S} \end{aligned}$$

EXERCISE 6.9

- Find the solution set by using the method of equating the coefficients.

<p>(i) $2x + 5y = -1$ $x - 2y = 4$</p> <p>(iii) $2x + 3y = 3$ $x + 5y = 5$</p> <p>(v) $2x - 3y = 6$ $3x + 5y = 0$</p>	<p>(ii) $x + y = 2$ $x - y = 0$</p> <p>(iv) $x - 4y = 4$ $4x - y = 16$</p> <p>(vi) $3x - 4y = 7$ $5x + y = 27$</p>
---	--
- Find the solution set by using the method of elimination by substitution.

<p>(i) $2x + 2y = 5$ $x - 2y = 3$</p> <p>(iii) $6x + y = 2$ $x - 4y = 15$</p> <p>(v) $2x - 4y = -10$ $y - 5x = -5$</p>	<p>(ii) $5x + 2y = 15$ $-2x + y = 4$</p> <p>(iv) $2x + 7y = 10$ $3x + y = 3$</p> <p>(vi) $x + 8y = 15$ $3x - y = 0$</p>
--	---
- Find the solution set by using the method of cross multiplication.

<p>(i) $2x - 7y = 11$ $5x - 10y = 10$</p> <p>(iii) $2x - 9y + 10 = 0$ $3x - 5y - 10 = 0$</p> <p>(v) $9x - 11y - 15 = 0$ $7x - 13y - 25 = 0$</p>	<p>(ii) $11x + 12y = 15$ $12x + 11y = -23$</p> <p>(iv) $5x + y - 56 = 0$ $x + 18y - 29 = 0$</p> <p>(vi) $2y - 10x - 86 = 0$ $2x + 5y - 11 = 0$</p>
---	--

6.5.2 Solving Real Life Problems Involving Two Simultaneous Linear Equations in two Variables

Example 4: A number is half of another number. The sum of 3 times of 1st number and 4 times of 2nd number is 22. Find the numbers.

Solution: Suppose that the numbers are x and y . Then according to given condition.

$$\begin{aligned} x &= \frac{y}{2} && \text{..... (i)} \\ 3x + 4y &= 22 && \text{..... (ii)} \end{aligned}$$

From equation (i) we get,

$$x = \frac{y}{2} \Rightarrow y = 2x \quad \dots\dots\dots \text{(iii)}$$

Put the value of "y" in equation (ii)

$$3x + 4(2x) = 22 \Rightarrow 3x + 8x = 22 \Rightarrow 11x = 22 \Rightarrow x = \frac{22}{11} = 2$$

Put the value of "x" in equation (iii)

$$y = 2x \Rightarrow y = 2(2) = 4$$

Thus, the numbers are 2 and 4.

Example 5: 11 years ago Ali's age was 5 times of Waleed's age. But after 7 years Ali's age will be 2 times of Waleed's age. Find their ages.

Solution: Suppose that Ali's age is "x" years and Waleed's age is "y" years.

Before 11 years their ages were:

Ali's age = (x - 11) years, Waleed's age = (y - 11) years

Then according to the given condition,

Ali's age = 5 (Waleed's age)

$$\Rightarrow x - 11 = 5(y - 11)$$

$$\Rightarrow x - 11 = 5y - 55$$

$$\Rightarrow x - 5y = -55 + 11$$

$$\Rightarrow x - 5y = -44 \quad \dots\dots\dots \text{(i)}$$

After 7 years their ages will be:

Ali's age = (x + 7) years, Waleed's age = (y + 7) years

Then according to the given condition,

Ali's age = 2 (Waleed's age)

$$\Rightarrow x + 7 = 2(y + 7)$$

$$\Rightarrow x + 7 = 2y + 14$$

$$\Rightarrow x - 2y = 14 - 7$$

$$\Rightarrow x - 2y = 7 \quad \dots\dots\dots \text{(ii)}$$

By solving equation (i) and (ii).

$$x - 5y = -44 \quad \dots\dots\dots \text{(i)}$$

$$\pm x \mp 2y = \pm 7 \quad \dots\dots\dots \text{(ii)}$$

$$-3y = -51 \text{ (By subtracting)}$$

$$\Rightarrow y = 17$$

Put the value of "y" in equation (ii)

$$x - 2y = 7$$

$$\Rightarrow x - 2(17) = 7$$

$$\Rightarrow x - 34 = 7$$

$$\Rightarrow x = 34 + 7 = 41$$

Thus, Ali's age = 41 years and Waleed's age = 17 years.

Example 6: If numerator and denominator of a fraction are increased by 5, the fraction becomes $\frac{1}{2}$ and if numerator and denominator are decreased by 3, the fraction becomes $\frac{2}{5}$. Find the fraction.

Solution: Suppose the numerator is x and denominator is y , therefore the fraction is $\frac{x}{y}$. Then, according to the given condition.

$$\frac{x+5}{y+5} = \frac{1}{2} \Rightarrow 2(x+5) = y+5 \Rightarrow 2x+10 = y+5 \Rightarrow 2x-y = -5$$

$$\Rightarrow y = 2x+5 \quad \dots\dots\dots (i)$$

Then, by the second condition.

$$\frac{x-3}{y-3} = \frac{2}{5}$$

$$\Rightarrow 5(x-3) = 2(y-3)$$

$$\Rightarrow 5x-15 = 2y-6$$

$$\Rightarrow 5x-2y = 15-6$$

$$5x-2y = 9 \quad \dots\dots\dots (ii)$$

Put the value of “ y ” from equation (i), in equation (ii) we have,

$$5x-2(2x+5) = 9$$

$$\Rightarrow 5x-4x-10 = 9$$

$$\Rightarrow x-10 = 9$$

$$\Rightarrow x = 10+9 = 19$$

Put the value of “ x ” in equation (i),

$$y = 2x+5 \quad \dots\dots\dots (iii)$$

$$\Rightarrow y = 2(19)+5$$

$$\Rightarrow y = 38+5$$

$$\Rightarrow y = 43$$

Thus, the required fraction is $\frac{19}{43}$

EXERCISE 6.10

- Ahmad added 5 in the twice of a number. Then he subtracted half of the number from the result. Finally, he got the answer 8. Find the number.
- If we add 3 in the half of a number, we get the same result as we subtract 1 from the quarter of the number. Find the number.
- The sum of two numbers is 5 and their difference is 1. Find the numbers.

4. The difference of two numbers is 4. The sum of twice of one number and 3 times of the other number is 43. Find the numbers.
5. Adnan is 7 years older than Adeel. Find their ages when $\frac{1}{4}$ of Adnan's age is equal to the $\frac{1}{2}$ of Adeel's age.
6. 5 years ago Ahsan's age was 7 times of Shakeel's age but after 3 years Ahsan's age will be 4 times of Shakeel's age. Calculate their ages.
7. The denominator of a fraction is 5 more than the numerator. But if we subtract 2 from the numerator and the denominator of the fraction, we get $\frac{1}{6}$. Find the fraction.
8. Fida bought 3kg melons and 4kg mangoes for Rs.470. Anam bought 5kg melons and 6kg mangoes for Rs.730. Calculate the price of melons and mangoes per kg.
9. The cost of 2 footballs and 10 basketballs is Rs.2300 and the cost of 7 footballs and 5 basketballs is Rs.2650. Calculate the price of each football and basketball.
10. If the numerator and denominator of a fraction are increased by 1, the fraction becomes $\frac{2}{3}$ and if the numerator and denominator of same fraction are decreased by 2, it becomes $\frac{1}{3}$. Find the fraction.
11. If the numerator and denominator of a fraction are decreased by 1, the fraction becomes $\frac{1}{2}$. If the numerator and denominator of the same fraction are decreased by 3, it becomes $\frac{1}{4}$. Find the fraction.

6.6 ELIMINATION

Look at the following simultaneous linear equations.

$$x + 5 = 8 \quad \dots\dots\dots (i)$$

$$x - 1 = 1 \quad \dots\dots\dots (ii)$$

From above it can be seen that the equation (i) is true for $x = 3$ and the equation (ii) is true for $x = 2$, but both equations are not true for a unique value of x .

Now observe the following simultaneous linear equations.

$$x + a = 5 \quad \dots\dots\dots (iii)$$

$$x + b = 4 \quad \dots\dots\dots (iv)$$

Here the equation (iii) is true for $x = 5 - a$ and the equation (iv) is true for $x = 4 - b$. While finding a single value of x for which both the equations are true, we put

$$\begin{aligned} 5 - a &= 4 - b \\ \Rightarrow a - b &= 5 - 4 \\ \Rightarrow a - b &= 1 \qquad \dots\dots\dots (v) \end{aligned}$$

It can be noted that a new relation (v) is established here which is independent of x . This process is called elimination and the relation $a - b = 1$ is called eliminated.

6.6.1 ELIMINATION OF A VARIABLE FROM TWO EQUATIONS

At least two equations are required for elimination of one variable. There are different methods of elimination, but we learn here only two methods through examples.

(a) Elimination of Variable from two Equations by Substitution

Example 1: Eliminate “ x ” from the following equations by substitution method.

$$\begin{aligned} ax - b &= 0 \\ cx - d &= 0 \end{aligned}$$

Solution: Given:

$$\begin{aligned} ax - b &= 0 \qquad \dots\dots\dots (i) \\ cx - d &= 0 \qquad \dots\dots\dots (ii) \end{aligned}$$

From equation (i), we have

$$ax = b \qquad \text{or} \qquad x = \frac{b}{a}$$

Put the value of x in equation (ii), we get

$$c \left(\frac{b}{a} \right) - d = 0$$

$$\Rightarrow bc - ad = 0 \quad \Rightarrow \quad bc = ad \quad \text{Here “}x\text{” is eliminated.}$$

Example 2: Eliminate “ x ” from $ax^2 + bx + c = 0$ and $\ell x + m = 0$ by substitution method.

Solution:

$$\begin{aligned} ax^2 + bx + c &= 0 \qquad \dots\dots\dots (i) \\ \ell x + m &= 0 \qquad \dots\dots\dots (ii) \end{aligned}$$

From equation (ii), we have,

$$\ell x + m = 0 \Rightarrow x = \frac{-m}{\ell}$$

Put the value of x in equation (i)

$$a + b + c = 0$$

$$\Rightarrow a \frac{m^2}{\ell^2} - b \frac{m}{\ell} + c = 0$$

$$\Rightarrow \frac{am^2}{\ell^2} - \frac{bm}{\ell} + c = 0 \quad (\text{Multiply equation by } \ell^2)$$

$$\Rightarrow am^2 - b\ell m + c\ell^2 = 0$$

This is the required result.

EXERCISE 6.11

1. Eliminate “x” from the following equations by substitution method.

(i) $ax - b = 0$

$cx - d = 0$

(iii) $x + a = b$

$x^2 + a^2 = b^2$

(v) $x - m = \ell$

$(\ell - m)x + a = 0$

(ii) $2x + 3y = 5$

$x - y = 2$

(iv) $a - b = 2x$

$a^2 + b^2 = 3x^2$

2. Eliminate v_i from the following equations.

(i) $v_f = v_i + at$

$S = v_i t + \frac{1}{2} at^2$

(ii) $v_f = v_i + at$

$2aS = v_f^2 - v_i^2$

(iii) $v_f = v_i - gt$

$S = v_i t + \frac{1}{2} gt^2$

(b) **Elimination of a Variable from two Equations by Application of Formulas**

Example 3: Elimination of “x” from the following equations by using the formula.

$$x + \frac{1}{x} = \ell; \quad x^2 + \frac{1}{x^2} = m^2$$

Solution: $x + \frac{1}{x} = \ell$ (i)

and $x^2 + \frac{1}{x^2} = m^2$ (ii)

Taking square of both the sides of (i), we have

$$= (\ell)^2$$

or $x^2 + \frac{1}{x^2} + 2 = \ell^2$

or $x^2 + \frac{1}{x^2} = \ell^2 - 2$ (iii)

Compare equations (ii) and (iii), we get

$$\ell^2 - 2 = m^2$$

This is the required relation.

Example 4: Eliminate “t” from the following equations.

$$x = \frac{2at}{1+t^2}, \quad y = \frac{b(1-t^2)}{1+t^2}$$

Solution: $x = \frac{2at}{1+t^2}$ (i) , $y = \frac{b(1-t^2)}{1+t^2}$ (ii)

Equation (i) gives

$$\frac{x}{a} = \frac{2t}{1+t^2}$$

or $\quad =$ (Taking square of both the sides)

or $\frac{x^2}{a^2} = \frac{4t^2}{1+2t^2+t^4}$ (iii)

Equation (ii) gives

$$\frac{y}{b} = \frac{1-t^2}{1+t^2}$$

or $\quad =$ (Taking square of both the sides)

or $\frac{y^2}{b^2} = \frac{1-2t^2+t^4}{1+2t^2+t^4}$ (iv)

By adding equations (iii) and (iv),

we have, $\frac{x^2}{a^2} + \frac{y^2}{b^2} = \frac{4t^2}{1+2t^2+t^4} + \frac{1-2t^2+t^4}{1+2t^2+t^4}$

$$\frac{x^2}{a^2} + \frac{y^2}{b^2} = \frac{4t^2 + 1 - 2t^2 + t^4}{1 + 2t^2 + t^4} = \frac{1 + 2t^2 + t^4}{1 + 2t^2 + t^4} = 1$$

Thus, $\frac{x^2}{a^2} + \frac{y^2}{b^2} = 1$, is the required solution.

EXERCISE 6.12

1. Eliminate “x” from the following equations by using appropriate formula.

(i)	$x - \frac{1}{x} = m ; x^2 + \frac{1}{x^2} = n^2$	(ii)	$x - \frac{1}{x} = \frac{a}{2} ; x^2 + \frac{1}{x^2} = b^2$
(iii)	$\frac{x^2}{\ell^2} + \frac{\ell^2}{x^2} = b^2 ; \frac{\ell}{x} - \frac{x}{\ell} = a$	(iv)	$\frac{x}{c} + \frac{c}{x} = 2a ; \frac{x}{c} - \frac{c}{x} = 3b$
(v)	$x - \frac{1}{x} = \ell ; x^3 - \frac{1}{x^3} = m^3$	(vi)	$x - \frac{1}{x} = p ; x^2 + \frac{1}{x^2} = 2q^2$
(vii)	$x^2 + \frac{1}{x^2} = 3m^2 ; x^4 + \frac{1}{x^4} = n^4$	(viii)	$x - \frac{1}{x} = a ; x^4 + \frac{1}{x^4} = a^4$

2. Eliminate “t” from the following equations.

(i)	$at^2 = x$	(ii)	$x - y = 2t$
	$bt^3 = y$		$x^2 + y^2 = 3t^2$

REVIEW EXERCISE 6

1. Four options are given against each statement. Encircle the correct one.

- i. The square of 99 by formula is:

(a)	$(100)^2 - 2(100)(1) + (1)^2$	(b)	$(100)^2 + 2(100)(1) + (1)^2$
(c)	$(100)^2 + 2(100)(1) - (1)^2$	(d)	$(100)^2 - 2(100)(1) - (1)^2$

- ii. If $x + \frac{1}{x} = 9$, then $x^2 + \frac{1}{x^2} = ?$

(a)	81	(b)	18	(c)	27	(d)	79
-----	----	-----	----	-----	----	-----	----

- iii. The correct factorization of $5y(y-3) + 4(y-3)$ is:

(a)	$(5y + y)(4 - 3)$	(b)	$(5y - 3)(y - r)$
(c)	$(5y + 4)(y - 3)$	(d)	$(y + 3)(5y + 4)$

- iv. The factorization of $4x^2 - 12xy + 9y^2$ is:

(a)	$(2x + 3y)(2x - 3y)$	(b)	$(2x - 3y)(2x - 3y)$
(c)	$(2x + 3y)(2x + 3y)$	(d)	$(2x - 3y)(2x + 3y)$

- v. If $x - \frac{1}{x} = 3$, then $x^3 - \frac{1}{x^3} = ?$
 (a) 27 (b) 18 (c) 30 (d) 36
- vi. If $x + y = 6$, $x - y = 2$, then $y = ?$
 (a) 4 (b) 2 (c) 6 (d) 8
- vii. After eliminating "x" from $ax^2 = b$ and $cx^2 = d$, we get:
 (a) $bc = ad$ (b) $bd = ac$ (c) $\frac{a}{b} = \frac{c}{d}$ (d) $abc = d$
- viii. After eliminating x from $x + \frac{1}{x} = b$, $x^2 + \frac{1}{x^2} = a^2$, we get:
 (a) $a^2 = b^2 + 2$ (b) $a^2 + b^2 = 2$
 (c) $a^2 - b^2 = -2$ (d) $a^2 + b^2 = -2$
2. Answer the following questions.
- What are the simultaneous linear equations?
 - Write any three methods for solving simultaneous linear equations.
 - How many equations are required for elimination of one variable?
3. Find the value of $x^4 + \frac{1}{x^4}$, when $x + \frac{1}{x} = 7$.
4. Factorize the following:
 i. $3xy + 6x^2y^2 + 9xz$ ii. $y^4 - 12y^2 + 36$ iii. $x^8 - y^8$
5. Find the cube of the following:
 i. 13 ii. $2x - 3y$ iii. $7a - b$
6. If $x + \frac{1}{x} = 5$, then find the value of $x^3 + \frac{1}{x^3}$.
7. Eliminate "x" by substitution method from the following equations.
 i. $ax - b = 0$, $cx^2 + mx = 0$ ii. $\ell x - n = 0$, $sx^2 + tx + u = 0$
8. Eliminate "x" from the following equations by using formula.
 i. $x + \frac{1}{x} = \frac{a}{3}$, $x^2 + \frac{1}{x^2} = b^2$ ii. $x + \frac{1}{x} = 3b$, $x^3 + \frac{1}{x^3} = a^3$
 iii. $x - \frac{1}{x} = a$, $x^4 + \frac{1}{x^4} = b^4$

9. If the numerator and denominator of a fraction are increased by 1, the fraction becomes $\frac{3}{4}$ and if the numerator and denominator of same fraction are decreased by 1, it becomes $\frac{2}{3}$. Find the fraction.
10. Eliminate “ t ” from the following equations.

$$(i) \quad x = \frac{1+t^2}{1-t^2}, \quad y = \frac{2at}{1-t^2}$$

$$(ii) \quad x = \frac{1+t^2}{2at}, \quad y = \frac{b(1-t^2)}{1+t^2}$$

SUMMARY

- Three basic algebraic formulas are:
 - i. $(a + b)^2 = a^2 + 2ab + b^2$
 - ii. $(a - b)^2 = a^2 - 2ab + b^2$
 - iii. $a^2 - b^2 = (a + b)(a - b)$
- Expressing polynomials as product of two or more polynomials that cannot be further expressed as product of factors is called Factorization.
- The cubic formulas are:
 - i. $(a + b)^3 = a^3 + 3a^2b + 3ab^2 + b^3$
 - ii. $(a - b)^3 = a^3 - 3a^2b + 3ab^2 - b^3$
- If a and b are real numbers (and if a and b are not both equal to 0) then $ax + by = r$ is called a linear equation in two variables x and y , a and b are coefficients and r is constant of the equation.
- Simultaneous linear equations mean a collection of linear equations all of which are satisfied by the same values of the variables.
- The general form of the simultaneous linear system of equations in two variables is:

$$a_1x + b_1y + c_1 = 0$$

$$a_2x + b_2y + c_2 = 0$$



After completion of this unit, the students will be able to:

- Define Parallel lines
- Demonstrate through figures the following properties of parallel lines:
 - Two lines which are parallel to the same given line are parallel to each other,
 - If three parallel lines are intersected by two transversals in such a way that the two intercepts on one transversal are equal to each other, the two intercepts on the second transversal are also equal,
 - A line through the midpoint of the side of a triangle parallel to another side bisects the third side (an application of above property).
- Draw a transversal to intersect two parallel lines and demonstrate corresponding angles, alternate interior angles, vertically opposite angles and interior angles on the same side of transversal.
- Describe the following relations between the pairs of angles when a transversal intersects two parallel lines:
 - Pairs of corresponding angles are equal,
 - Pairs of alternate interior angles are equal,
 - Pair of interior angles on the same side of transversal is supplementary and demonstrate them through figures.
- Define Polygon.
- Demonstrate the following properties of a parallelogram:
 - Opposite sides of a parallelogram are equal,
 - Opposite angles of a parallelogram are equal,
 - Diagonals of a parallelogram bisect each other.
- Define regular pentagon, hexagon and octagon.
- Demonstrate a point lying in the interior and exterior of a circle.
- Describe the terms; sector, secant and chord of circle, concyclic points, tangent to a circle and concentric circles.

7.1 Parallel Lines

7.1.1 Definition:

If two lines lying on the same plane never meet, touch or intersect at any point, then these are called parallel lines. Parallel lines are always the same distance apart. Some examples of parallel lines are shown below:

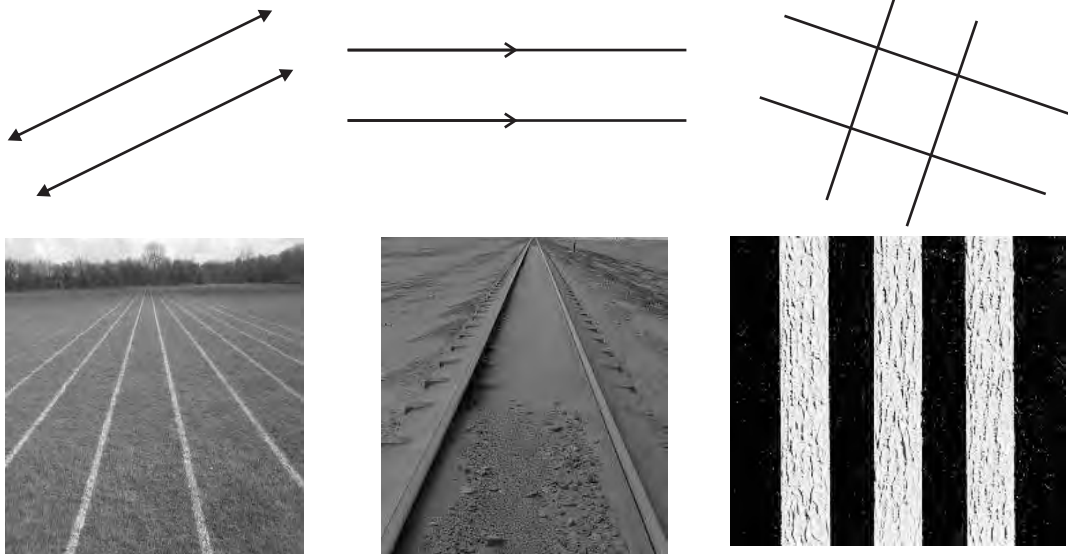

7.1.2 Demonstration of Properties of Parallel Lines

- Two lines which are parallel to the same given line are parallel to each other

Let two lines ℓ and n be parallel to the third line m as shown in figure 1. There is no intersection point of ℓ with m and n with m . All the points of line ℓ are equidistant from the line m . Similarly, the points of line n are also equidistant from the line m . Therefore, we cannot find a point common between ℓ and n which implies that ℓ is parallel to n .

In figure 2, the pairs of parallel line segments are $\overline{AB} \parallel \overline{CD}$, $\overline{AB} \parallel \overline{EF}$, $\overline{EF} \parallel \overline{GH}$ etc. Similarly, $\overline{CD} \parallel \overline{EF}$ or $\overline{AB} \parallel \overline{GH}$.

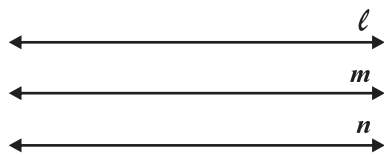

Figure 1

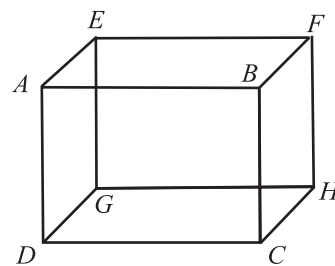

Figure 2

- If three parallel lines are intersected by two transversals in such a way that the two intercepts on one transversal are equal to each other, the two intercepts on the second transversal are also equal.

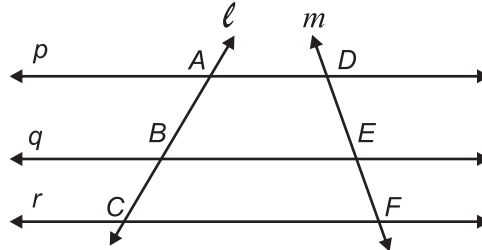

Figure 3

In the above figure the two transversals l and m intersect three parallel lines p , q and r at the points A , B , C , D , E and F . The intercepts formed by transversal l are \overline{AB} and \overline{BC} and intercepts by transversal m are \overline{DE} and \overline{EF} .

According to the above property of parallel lines if $m\overline{AB} = m\overline{BC}$ then $m\overline{DE} = m\overline{EF}$.

- A line through the midpoint of the side of a triangle parallel to another side bisects the third side (an application of above property)

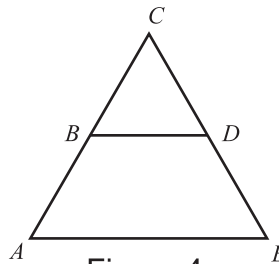

Figure 4

In figure 4, point B is the midpoint of \overline{AC} and $\overline{BD} \parallel \overline{AE}$, therefore, from the above property D is also the midpoint of \overline{CE} , i.e.,

$$m\overline{AB} = m\overline{BC} \text{ and } \overline{BD} \parallel \overline{AE}$$

$$\Rightarrow m\overline{CD} = m\overline{DE}$$

7.1.3 Special angles formed when a Transversal intersects Two Parallel Lines.

When a transversal intersects two parallel lines, angles formed are:

- Vertically opposite angles
- Corresponding angles
- Alternate interior angles
- Interior angles

Vertically opposite angles are formed when two straight lines intersect. The two angles are directly opposite each other through the vertex.

$\angle AOC$ and $\angle DOB$ are vertically opposite angles. $\angle AOD$ and $\angle COB$ are vertically opposite angles.

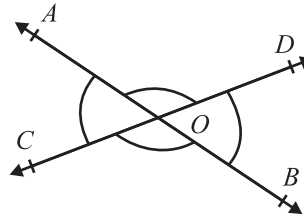

Corresponding Angle.

In the following figure the transversal ℓ intersects the two parallel lines m and n . Consider these pairs of angles

- $\angle 1$ and $\angle 5$
- $\angle 2$ and $\angle 6$
- $\angle 3$ and $\angle 7$
- $\angle 4$ and $\angle 8$

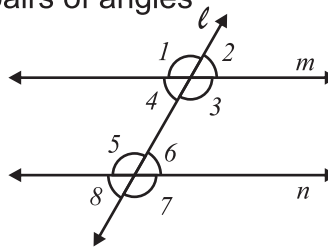

These pairs of angles are corresponding angles because both the angles are at the same position; both are on the same side of the transversal and at the same side of the two parallel lines.

Alternate Interior Angle

Consider the following figure in which transversal ℓ intersects two parallel lines x and "y."

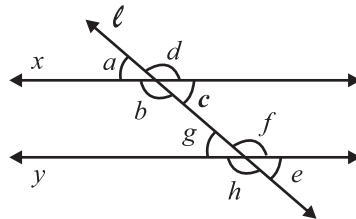

The pair of angles $\angle b, \angle f$ and $\angle c, \angle g$ both the angles are on opposite sides of the transversal and between the two parallel lines. These angles are called alternate interior angles.

Interior Angle

Consider the pair of angles marked $\angle 1, \angle 3$ and $\angle 2, \angle 4$. In which, both the angles in a pair are on the same side of the transversal and between the two parallel lines. These angles are called interior angles.

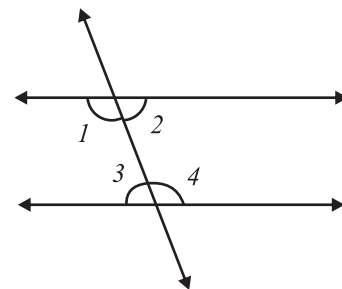

Example 1:

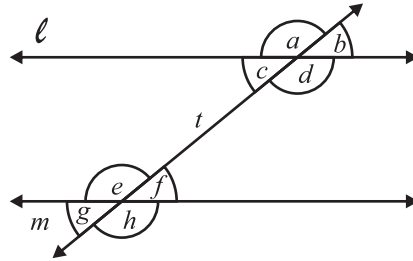

If two lines l and m are parallel and intersected by a transversal t then identify the special angles thus formed.

Solution:

- Vertically opposite angles are: a, d and b, c and e, h and f, g .
- Corresponding angles on the same side of the transversal are a, e and c, g .
- Alternate interior angles are: c, f and d, e .
- Interior angles are: c, e and d, f .

7.1.4 Relationship Between the Pairs of Angles when a Transversal Intersects Two Parallel Lines

When a transversal intersects parallel lines then:

- Corresponding angles are equal in size
- Alternate angles are equal in size
- Interior angles are supplementary, or add up to 180°

Consider the following figure in which $\overline{AB} \parallel \overline{CD}$ and \overline{EF} is the transversal.

- The pairs of corresponding angles are $\angle 1, \angle 5$; $\angle 3, \angle 7$; $\angle 2, \angle 6$ and $\angle 4, \angle 8$

All these pairs of angles are equal in measure i.e.,

$$m\angle 1 = m\angle 5, m\angle 2 = m\angle 6, m\angle 3 = m\angle 7, \text{ and } m\angle 4 = m\angle 8$$

- The pairs of alternate interior angles are $\angle 3, \angle 5$ and $\angle 4, \angle 6$. Both alternate pairs of angles are equal in measurement. $m\angle 3 = m\angle 5$ and $m\angle 4 = m\angle 6$

- The pairs of alternate interior angles on the same side of the transversal are $\angle 3, \angle 6$ and

$\angle 4, \angle 5$. These angles are supplementary angles i.e., $m\angle 3 + m\angle 6 = 180^\circ$ and $m\angle 4 + m\angle 5 = 180^\circ$

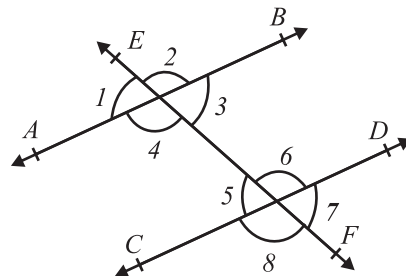

Example 2: Determine the values of angles A , B , C and D in the figure to the right where the lines p and q are parallel to each other.

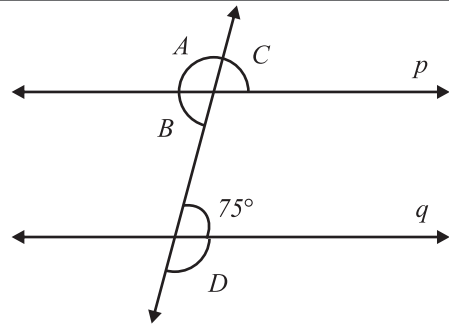

Solution:

Since $\angle B$ is the alternate interior angle to the given angle of 75° . So $m\angle B = 75^\circ$

$\angle C$ and the given angle of 75° are corresponding angles so, $m\angle C = 75^\circ$

$\angle A$ and $\angle B$ are angles of the straight line on the same side of the transversal,

Thus $m\angle A + m\angle B = m\angle A + 75^\circ = 180^\circ$

$$m\angle A = 180^\circ - 75^\circ = 105^\circ$$

Similarly, $\angle D$ is an adjacent supplementary angle to the given angle 75°

So, $m\angle D + 75^\circ = 180^\circ$

$$m\angle D = 180^\circ - 75^\circ = 105^\circ$$

Thus $m\angle A = 105^\circ, m\angle B = 75^\circ, m\angle C = 75^\circ$ and $m\angle D = 105^\circ$

Example 3: Find the value of x , y and z , where lines a and b are parallel and lines c and d are parallel to each other.

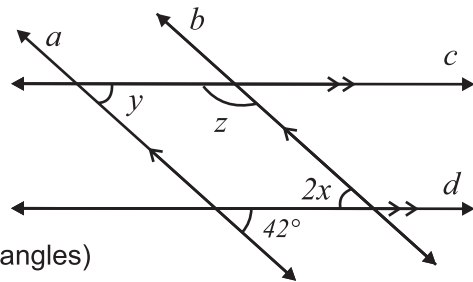

Solution:

Since $a \parallel b$, $2x = 42^\circ$ (alternate interior angles)

$$m\angle x = 21^\circ$$

Again $c \parallel d$, $m\angle y = 42^\circ$ (corresponding angles)

$m\angle y + m\angle z = 180^\circ$ (interior angles)

$$42^\circ + z = 180^\circ$$

$$m\angle z = 180^\circ - 42^\circ = 138^\circ$$

Note: Measurements of the given angles and sides are not as per mentioned values.

EXERCISE 7.1

1. Find the measure of $\angle PQR$

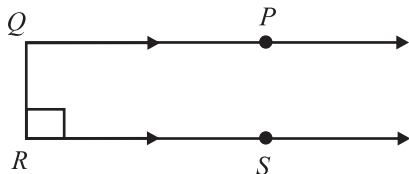

2. Find the value of "x"

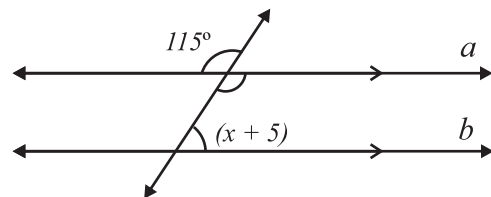

3. If $m\angle 3 = 68^\circ$ and $m\angle 8 = (2x + 4)^\circ$, what is the value of x ? Show your steps.

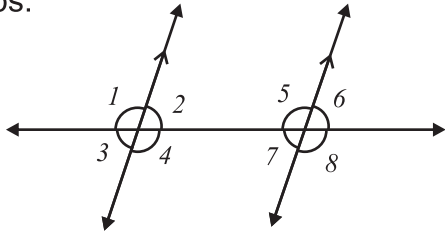

4. If $m\angle 1 = 105^\circ$, find $m\angle 4$, $m\angle 5$, and $m\angle 8$. Indicate which property is used.

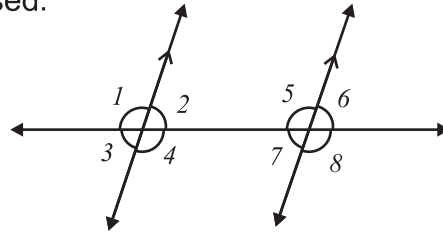

5. Solve for "x". Also find the angle.

(i)

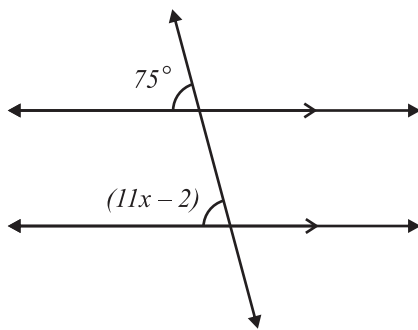

(ii)

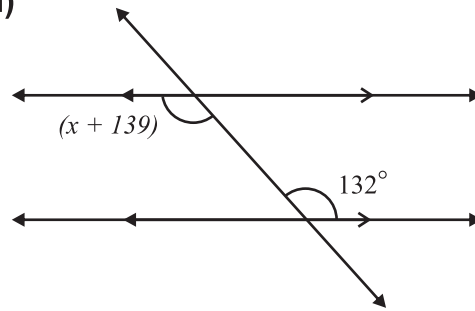

(iii)

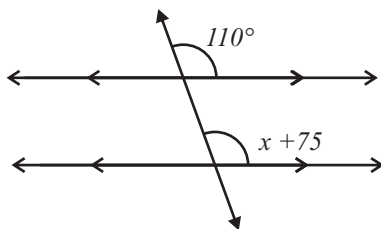

(iv)

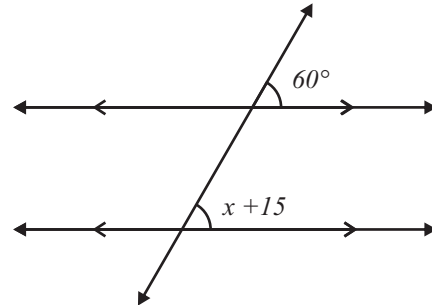

7.2 Polygons

7.2.1 Define a Polygon

A polygon is a closed plane figure with three or more straight sides. Polygons are named according to the number of sides. The names of some polygons are given below:

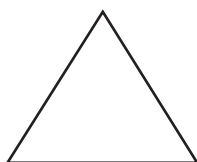

Triangle-3 sides

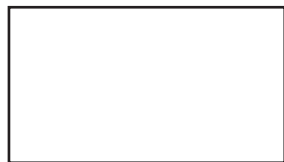

Quadrilateral-4sides

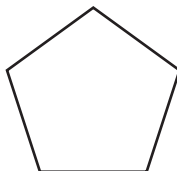

Pentagon-5 sides



Hexagon-6sides

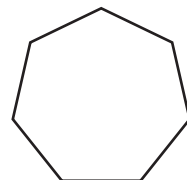

Heptagon-7 sides

7.2.2 Demonstrate the properties of a parallelogram

A parallelogram is a special type of quadrilateral whose pairs of opposite sides are parallel. For example quadrilateral $ABCD$ is a parallelogram because $\overline{AB} \parallel \overline{DC}$ and $\overline{AD} \parallel \overline{BC}$.

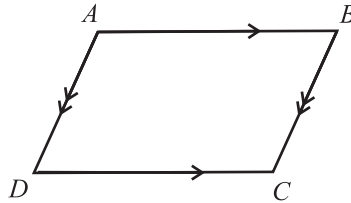

A parallelogram has the following properties:

- i. A parallelogram is a quadrilateral with both pairs of opposite sides parallel.

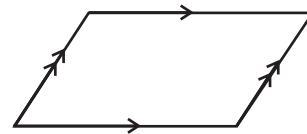

- ii. In a parallelogram, the 2 pairs of opposite sides are congruent.

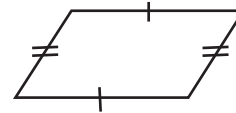

- iii. In a parallelogram, the 2 pairs of opposite angles are congruent.



- iv. In a parallelogram, the sum of two consecutive interior angles are supplementary

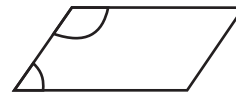

- v. In a parallelogram, the diagonals bisect each other.

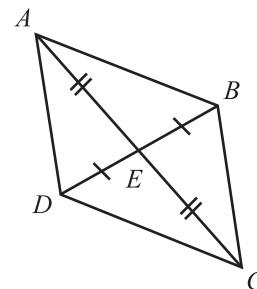

7.2.3 Define regular pentagon, hexagon and octagon

A polygon in which all the sides are of equal length is called a regular polygon. All angles of regular polygon also are of same measurement.

- Regular Pentagon:** A five sided polygon in which all the five sides and interior angles are of same size is called a regular pentagon. The sum of measures of all the interior angles of a regular pentagon is 540° . The size of each interior angle of a regular pentagon is $\frac{540^\circ}{5} = 108^\circ$.
- Regular Hexagon:** A six sided polygon in which all the six sides and interior angles are of same size is called a regular hexagon. The sum of measures of all the interior angles of a regular hexagon is 720° . The size of each interior angle of a regular hexagon is $\frac{720^\circ}{6} = 120^\circ$.
- Regular Octagon:** An eight sided polygon in which all the eight sides and interior angles are of same size is called a regular octagon. The sum of measures of all the interior angles of a regular octagon is 1080° . The size of each interior angle of a regular octagon is $\frac{1080^\circ}{8} = 135^\circ$.

Example 1: Given that $QRST$ is a parallelogram, find the value of x in the diagram below.

Solution:

Since opposite sides of parallelograms are congruent, we have $m\angle(x+15) = 127^\circ$ (Opposite angel in a parallelogram).

$$m\angle x = 127 - 15 = 112^\circ$$

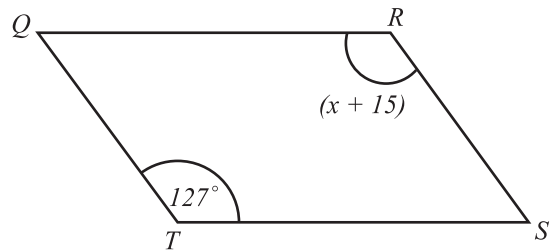

Example 2: Given that $DEFG$ is a parallelogram, determine the values of x and y .

Solution:

From the figure we get $m\angle G = 70^\circ + 45^\circ = 115^\circ$

Since $\overline{ED} \parallel \overline{FG}$, we have $m\angle G + m\angle D = 180^\circ$

$$115^\circ + m\angle D = 180^\circ$$

$$m\angle D = 180^\circ - 115^\circ = 65^\circ$$

$$m\angle D = 5y = 65$$

$$y = 13$$

Also $m\angle F = m\angle D$

$$m\angle(7x - 5) = 65^\circ$$

$$7x - 5 = 65$$

$$7x = 70$$

$$x = 10$$

So, we have $x = 10$ and $y = 13$.

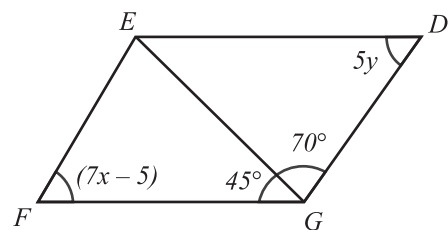

Example 3: Given that $ABCD$ is a parallelogram, find the value of x .

Solution: We know that in parallelogram the diagonals bisect each other.

Thus, we get

$$\begin{aligned}
 m \overline{DE} &= m \overline{BE} \\
 4x^2 + 5cm &= 41cm \\
 4x^2 &= 41 - 5 \\
 4x^2 &= 36 \\
 x^2 &= 9 \\
 x &= 3
 \end{aligned}$$

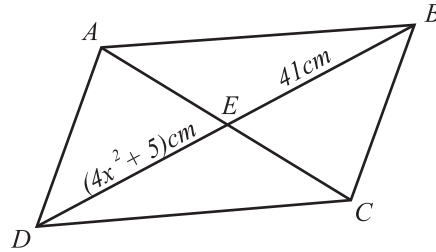

EXERCISE 7.2

1. Find the value of the unknown from the following parallelogram.

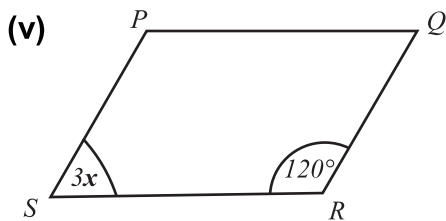
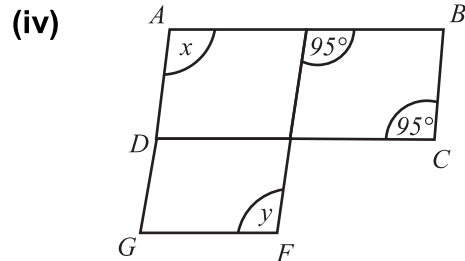
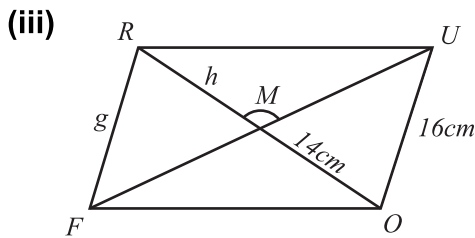
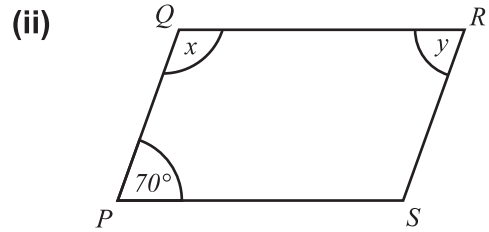
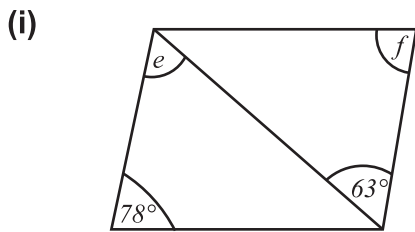

7.3 CIRCLE

A circle is a simple plane shape of geometry also called a simple closed curve, such that all its points are at the same distance from a given point.

7.3.1 Demonstrate a Point Lying in the Interior and Exterior of a Circle

A circle divides the plane into two regions: an interior and an exterior. In everyday use, the term “circle” may be used interchangeably to refer to either the boundary of the figure, or to the whole figure including its interior in strict technical usage, the circle is the former and the latter is called a disk. For example “*A*” is outside the circle, “*B*” is inside the circle and “*C*” is on the circle.



7.3.2 Describe the terms in Circle

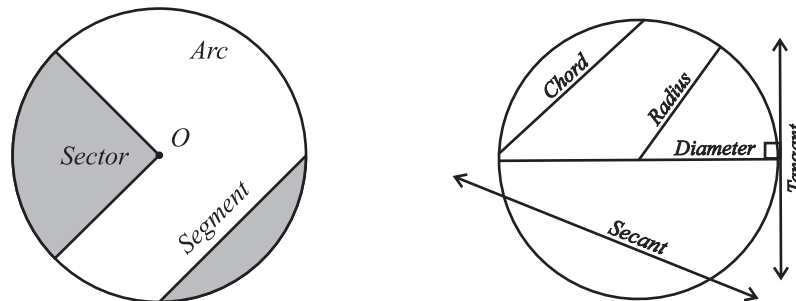

- **Arc:** Any part of boundary of the circle.
- **Chord:** It is a line segment whose endpoints lie on the circle.
- **Secant:** It is a straight line cutting the circle at two points. It is an extended chord.
- **Sector:** A region bounded by two radii and an arc lying between the radii.
- **Segment:** A region bounded by a chord and an arc lying between the chord's endpoints.
- **Tangent:** A straight line that touches the circle at a single point externally.
- **Concyclic:** A set of points are said to be concyclic (or cocyclic) if they lie on a common circle.

EXERCISE 7.3

1. For each of the following parallelogram calculate the unknown angles marked x , y and z

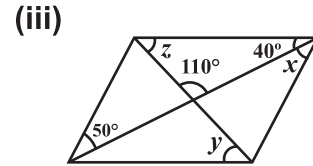
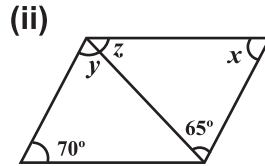
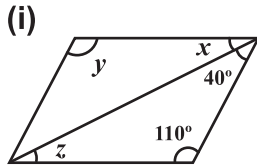

- In a parallelogram, one angle is 28° greater than the other. Find the angles of the parallelogram.
- If one angle of a parallelogram is four times greater than the other. Find the angles of the parallelogram.
- The measure of one angle of a parallelogram is 85° . What are the measures of the other angles?
- In parallelogram $WXYZ$, the measure of angle $X = (4a - 40)$ and the measure of angle $Z = (2a - 8)$. Find the measure of angle W .

REVIEW EXERCISE 7

- Four options are given against each statement. Encircle the correct one.
 - If two lines on a plane that do not intersect each other at any point are called:

(a) parallel lines	(b) perpendicular lines
(c) transversal lines	(d) all of the above
 - Parallel lines are always:

(a) same distance apart	(b) intersect at one point
(c) overlap each other	(d) varied distance apart
 - If three parallel lines are intersected by two transversals in such a way that the two intercepts on one transversal are equal to each other, the two intercepts on the second transversal are:

(a) greater than the first one	(b) not equal
(c) smaller than the first one	(d) also equal
 - Vertically opposite angles are:

(a) congruent	(b) supplementary
(c) complementary	(d) unequal
 - Alternate interior angles are:

(a) congruent	(b) supplementary
(c) complementary	(d) unequal
 - A closed plane figure with three or more straight sides is called:

(a) polygon	(b) circle	(c) cone	(d) pyramid
-------------	------------	----------	-------------

- vii. A special type of quadrilateral whose pairs of opposite sides are parallel is called:
 (a) triangle (b) regular polygon (c) parallelogram (d) kite
- viii. Any connected part of circle is called:
 (a) chord (b) secant (c) sector (d) arc
- ix. A line segment whose end points lie on the circle is called:
 (a) chord (b) secant (c) sector (d) arc
- x. An extended chord, a straight line cutting the circle at two points is called:
 (a) chord (b) secant (c) sector (d) arc
- xi. A region bounded by two radii and an arc lying between the radii is called:
 (a) chord (b) secant (c) sector (d) arc
- xii. A straight line that touches the circle at a single point is called:
 (a) chord (b) secant (c) sector (d) tangent
- xiii. A region bounded by a chord and an arc lying between the chord's end points. is called:
 (a) chord (b) secant (c) sector (d) segment
2. Consider the following figure.

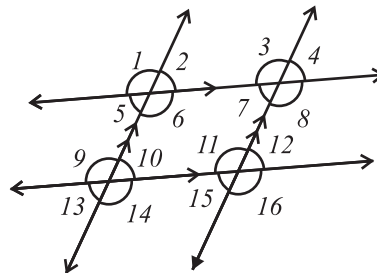

- a. Write the pair of:
 (i) corresponding angles (ii) alternate interior angles
 (iii) vertically opposite angles (iv) alternate exterior angles
- b. If $m\angle 1 = 125^\circ$, then find the measure of all the remaining angles.
3. Find the value of "x"

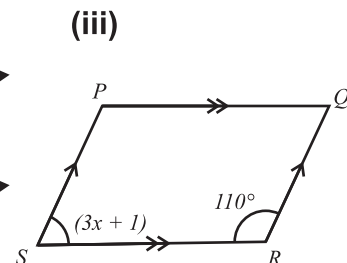
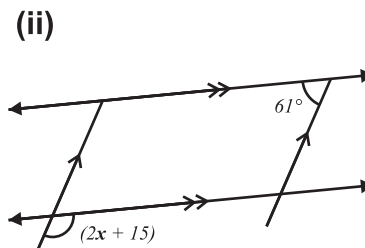
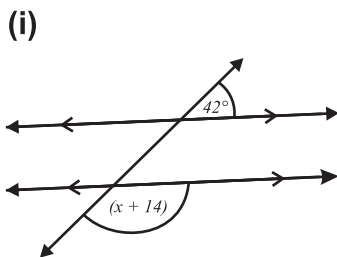

SUMMARY

- Two lines on a plane that do not intersect at any point are called parallel lines. Parallel lines are always the same distance apart.
- Two lines which are parallel to the same given line are parallel to each other.
- If three parallel lines are intersected by two transversals in such a way that the two intercepts on one transversal are equal to each other, the two intercepts on the second transversal are also equal.
- A line through the midpoint of the side of a triangle parallel to another side bisects the third side.
- When a transversal intersects two parallel lines then:
 - Corresponding angles are congruent.
 - Vertically opposite angles are congruent.
 - Alternate interior angles are congruent.
 - Interior angles are supplementary.
- A polygon is a closed plane figure with three or more straight sides.
- A parallelogram is a special type of quadrilateral whose pairs of opposite sides are parallel.
- A regular polygon's sides are all of the same length and all its angles have the same measure.
- A circle is a simple plane shape of geometry with all its points at the same distance (called the radius) from a fixed point (called the centre of the circle).
- Chord is a line segment whose endpoints lie on the circle.
- Secant is an extended chord, a straight line cutting the circle at two points.

- Sector is a region bounded by two radii and an arc lying between these two radii.
- Two or more circles with common centre and different radii are called concentric circles.
- A set of points are said to be concyclic (or cocyclic) if they lie on a common circle.
- Tangent is a straight line that touches the circle at a single point.



After completion of this unit, the students will be able to:

- Define and depict two converging (non-parallel) lines and find the angle between them without producing the lines.
- Bisect the angle between the two converging lines without producing them.
- Construct a square
 - When its diagonal is given.
 - When the difference between its diagonal and side is given.
 - When the sum of its diagonal and side is given.
- Construct a rectangle
 - When two sides are given.
 - When the diagonal and a side are given.
- Construct a rhombus
 - When one side and the base angle are given.
 - When one side and a diagonal are given.
- Construct a parallelogram
 - When two diagonals and the angle between them is given.
 - When two adjacent sides and the angle included between them is given.
- Construct a kite
 - When two unequal sides and a diagonal are given.
- Construct a regular pentagon
 - When a side is given.
- Construct a regular hexagon
 - When a side is given.
- Construct a right angled triangle
 - When hypotenuse and one side are given.
 - When hypotenuse and the vertical height from its vertex to the hypotenuse are given.

8.1 Define and depict two Converging (non-parallel) lines and find the angle between them without producing the lines

8.1.1 Definition:

Lines intersecting at a single point are called converging lines.

In the following figure, \overleftrightarrow{AB} and \overleftrightarrow{CD} are converging lines and \overleftrightarrow{LM} is a transversal intersecting these lines. Find the angle between converging lines.

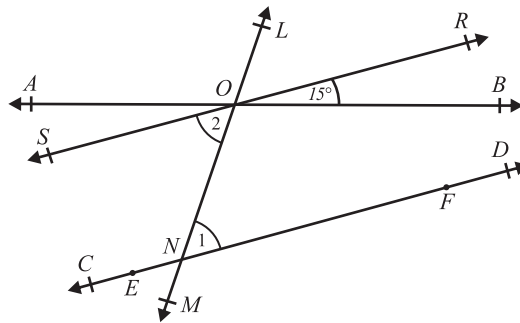

Steps of construction:

- i. \overleftrightarrow{AB} and \overleftrightarrow{CD} are two converging lines and \overleftrightarrow{LM} is the transversal which intersects these lines at point O and N .
- ii. Draw $m\angle 2 = m\angle 1$ with compass and straightedge. Thus \overleftrightarrow{SOR} is parallel to \overleftrightarrow{CD} .
- iii. Since \overleftrightarrow{CD} and \overleftrightarrow{SR} are parallel, therefore $m\angle BOR$ is the required angle.
- iv. Hence, angle between converging lines is 15° which is measured by using protractor.

8.1.2 Bisect the angle between two converging lines without producing them

We can find the angle bisector of two converging lines by performing the following steps:

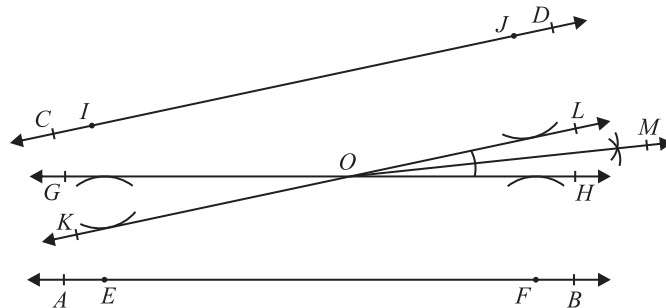

Steps of construction:

- i. \overleftrightarrow{AB} and \overleftrightarrow{CD} are two converging lines.
- ii. Draw two arcs of same radius from points E and F above \overleftrightarrow{AB} by using compass and draw \overleftrightarrow{GH} touching these arcs.
- iii. Also draw two arcs of same radius from points I and J below \overleftrightarrow{CD} by using compass and draw \overleftrightarrow{KL} touching these arcs.
- iv. $\angle HOL$ is the angle between the two convergent lines.
- v. Draw the bisector \overleftrightarrow{OM} of $\angle HOL$ which is the required bisector of given converging lines.

8.1.3 Construct a square**(a) When its diagonal is given.****Example 1:**

Draw a square $ABCD$ such that its diagonal is 4cm

Solution:

One of the diagonals of the square $ABCD$ is \overline{BD} and $m\overline{BD} = 4\text{cm}$.

[Note: In a square both the diagonals are of same length]

Steps of construction:

- i. Draw the diagonal $m\overline{BD} = 4\text{cm}$.
- ii. Draw a perpendicular bisector \overleftrightarrow{LM} of the diagonal \overline{BD} cutting it at point O .
- iii. With O as centre and radius $m\overline{OB}$, draw arcs cutting \overleftrightarrow{LM} at A and C .
- iv. Join A with B and D , and C with B and D , which gives the required square $ABCD$

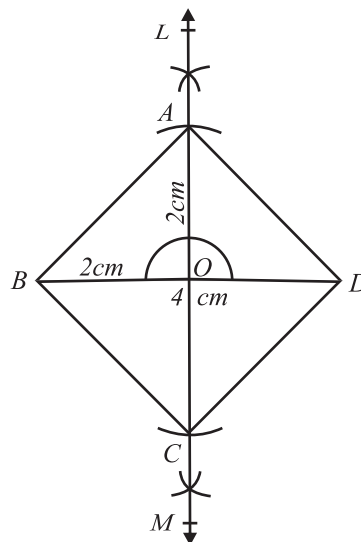

(b) When the difference between its diagonal and side is given

Example 2:

Draw a square $ABCD$ when the difference between its diagonal and side is equal to 2cm .

Solution:

Steps of construction:

- i. Draw \overleftrightarrow{PQ} and mark a point as A on it.
- ii. Construct $m\angle QAN = 90^\circ$ at A .
- iii. Draw two arcs of radius 2cm and centre at A which intersects \overleftrightarrow{AQ} at M and \overleftrightarrow{AN} at L .
- iv. Draw an arc of radius $= m\overline{LM}$ and centre at M which intersects \overleftrightarrow{AQ} at B .
- v. Draw an arc of radius $= m\overline{AB}$ and centre at A which intersects \overleftrightarrow{AN} at D .
- vi. Draw two arcs each of radius $= m\overline{AB}$, one centre at B and second centre at D . These arcs will intersect at point C .
- vii. Join C with D and B .

Hence, $ABCD$ is the required square.

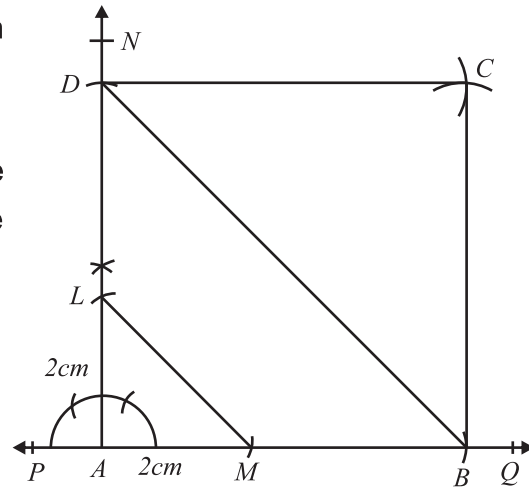

(c) When the sum of its diagonal and side is given

Example 3:

Draw a square $ABCD$ when the sum of its diagonal and side is equal to 3cm .

Solution:

Steps of construction:

- i. Draw \overleftrightarrow{PQ} and mark a point as S on it.
- ii. Construct $m\angle QSR = 90^\circ$ at point S .
- iii. Draw an arc of radius 3cm and centre at S intersecting \overleftrightarrow{SR} at L .
- iv. Draw an arc of radius 3cm and centre at S intersecting \overleftrightarrow{SQ} at A .

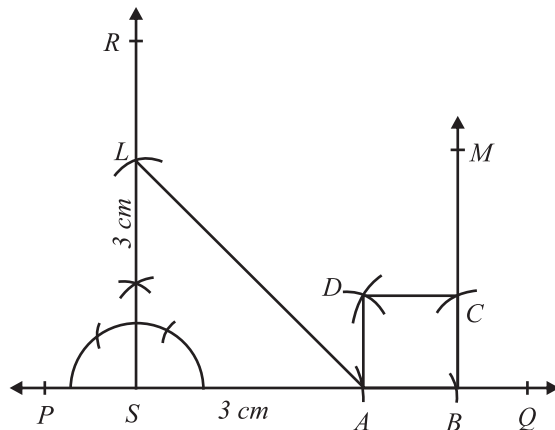

- v. Draw an arc of radius $= m\overline{AL}$ and centre at S which intersects \overrightarrow{SQ} at B . \overline{AB} is the side of the required square.
- vi. Draw perpendicular \overrightarrow{BM} at B .
- vii. Draw an arc of radius $m\overline{AB}$ and centre at B which intersects \overrightarrow{BM} at C .
- viii. Draw two arcs, each of radius $m\overline{AB}$, one with centre at A and second with centre at C which intersects at D .
- ix. Join C with D and D with A
Hence, $ABCD$ is the required square.

8.1.4 Construct a rectangle

(a) When two sides are given

Example 4:

Construct a rectangle $ABCD$ in which $m\overline{AB} = 4\text{ cm}$ and $m\overline{BC} = 5\text{ cm}$.

Solution:

Steps of construction:

- i. Draw $m\overline{AB} = 4\text{ cm}$.
- ii. Construct $m\angle A = m\angle B = 90^\circ$ and draw \overrightarrow{AG} and \overrightarrow{BH} .
- iii. Draw an arc with centre at A and of radius 5 cm which intersects the \overrightarrow{AG} at point D .
- iv. Draw an arc with centre at B and of radius 5 cm which intersects the \overrightarrow{BH} at point C .
- v. Join C with D .

Hence, $ABCD$ is the required rectangle.

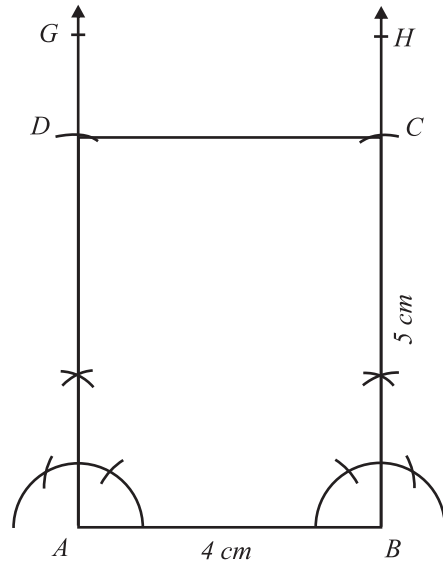

Note: Sum of interior angles of a quadrilateral is equal to 360°

(b) When the diagonal and a side are given**Example 5:**

Construct a rectangle $ABCD$ when
 $m\overline{AB} = 3\text{ cm}$ and $m\overline{AC} = 5\text{ cm}$

Solution:**Steps of construction:**

- i. Draw $m\overline{AB} = 3\text{ cm}$.
- ii. Construct $m\angle A = m\angle B = 90^\circ$ and draw \overrightarrow{AX} and \overrightarrow{BY} .
- iii. With centre at A and radius 5 cm draw an arc which intersects \overrightarrow{BY} at the point C .
- iv. With centre at B and radius 5 cm draw an arc which intersects \overrightarrow{AX} at the point D and joint C and D .

Hence, $ABCD$ is the required rectangle.

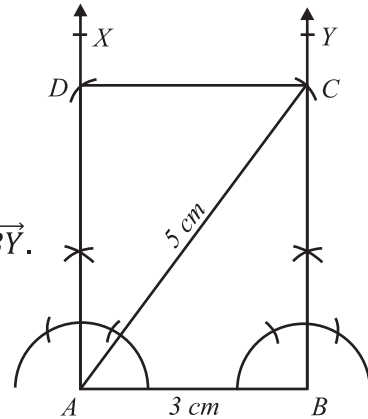
**8.1.5 Construct a rhombus****(a) When one side and the base angle are given.**

Example 6: Construct a rhombus $PQRS$ when the $m\overline{PQ} = 4\text{ cm}$ and $m\angle P = 45^\circ$

Solution:**Steps of construction:**

- i. Draw $m\overline{PQ} = 4\text{ cm}$.
- ii. Construct $m\angle P = 45^\circ$ and draw \overrightarrow{PX} .
- iii. Draw an arc with centre at P and radius 4 cm which intersects \overrightarrow{PX} at S .

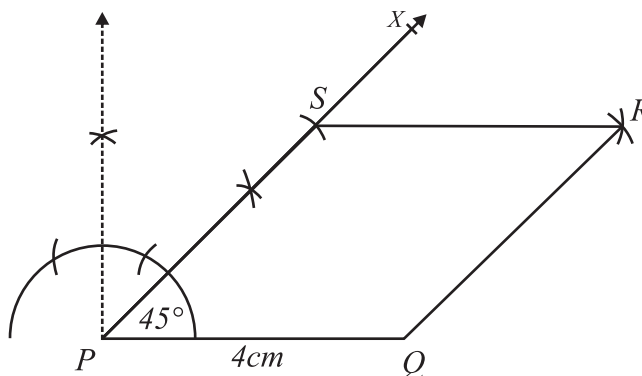

- iv. Draw an arc with centre at S and radius 4 cm .
- v. Draw an arc with centre at Q and radius 4 cm which intersects the previous arc drawn from S at R .
- vi. Join R with S and Q .

Hence, $PQRS$ is the required rhombus.

(b) When one side and a diagonal are given.**Example 7:**

Construct a rhombus $PQRS$, when $m\overline{PQ} = 3\text{cm}$ and $m\overline{PR} = 5\text{cm}$.

Solution:**Steps of construction:**

- Draw $m\overline{PQ} = 3\text{cm}$.
 - Draw an arc with centre at P and radius 5cm .
 - Draw an arc with centre at Q and radius 3cm which intersects the previous arc at R .
 - Draw an arc with centre at R and radius 3cm .
 - Draw an arc with centre at P and radius 3cm which intersects the previous arc at S .
 - Join Q with R , R with S and P with S .
- Hence, $PQRS$ is the required rhombus.

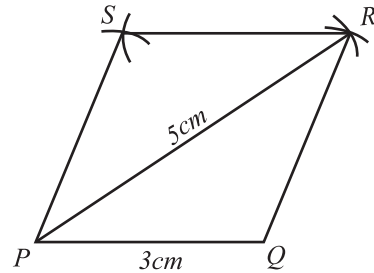
**8.1.6 Construct a parallelogram****(a) When two diagonals and the angle between them is given.****Example 8:**

Construct a parallelogram $ABCD$ whose diagonals are 3cm and 5cm and the angle between them is 75° .

Solution:**Steps of construction:**

- Draw the diagonal $m\overline{AC} = 3\text{cm}$.
- Bisect \overline{AC} with O as the midpoint.
- Construct an angle 75° at the point O and extend the line on both sides.
- From O , draw an arc of radius 2.5cm on both sides of \overline{AC} to cut the above line at B and D .
- Join A with B and D .
- Join C with B and D .

Hence, $ABCD$ is the required parallelogram.

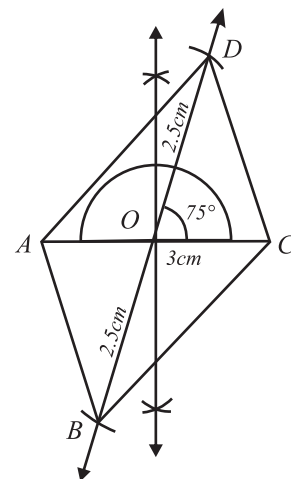

(b) When two adjacent sides and the angle included between them are given

Example 9:

Construct a parallelogram $PQRS$ when $m\overline{PQ} = 4\text{cm}$, $m\overline{PS} = 7\text{cm}$ and included angle between these sides is $m\angle QPS = 60^\circ$.

Solution:

Steps of construction:

- i. Draw a line segment $PQ = 4\text{cm}$.
- ii. Construct $m\angle QPX = 60^\circ$ at point P .
- iii. Draw an arc with centre at P and radius 7cm which intersects \overrightarrow{PX} at point S .
- iv. Draw an arc with centre at Q and radius 7cm above point Q .

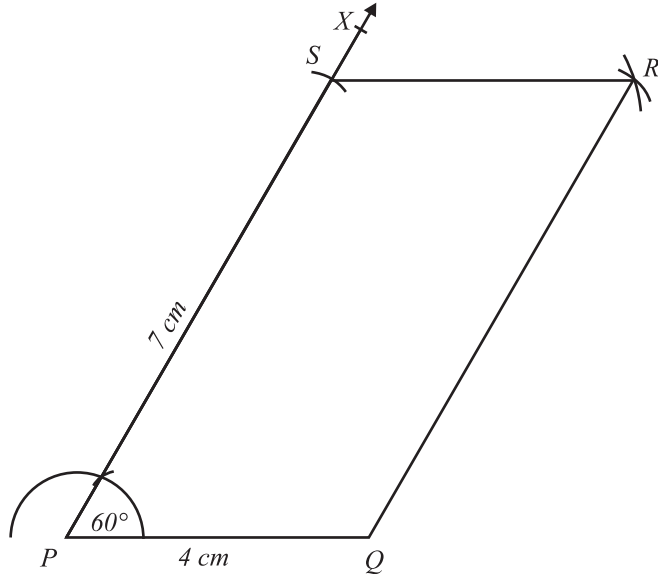

- v. Draw an arc with centre at S and radius 4cm which intersects the arc drawn from point Q at R .
- vi. Join R with S and Q to R to form the required parallelogram $PQRS$.

8.1.7 Construct a kite when two unequal sides and a diagonal are given

Example 10:

Construct a kite $PQRS$ when $m\overline{PQ} = 4\text{cm}$, $m\overline{QR} = 6\text{cm}$ and the length of the longer diagonal is $m\overline{PR} = 8\text{cm}$.

Solution:

Steps of construction:

- i. Draw $m\overline{PQ} = 4\text{cm}$.
- ii. Draw an arc with centre at Q and radius 6cm .

- iii. Draw an arc with centre at P and radius 8 cm . It intersects the previous arc at point R .
 - iv. Draw an arc with centre P and radius 4 cm above P .
 - v. Draw an arc with centre at R and radius 6 cm which intersects the arc drawn from P at S .
 - vi. Join R with Q and S and P with S .
- Hence, $PQRS$ is the required kite

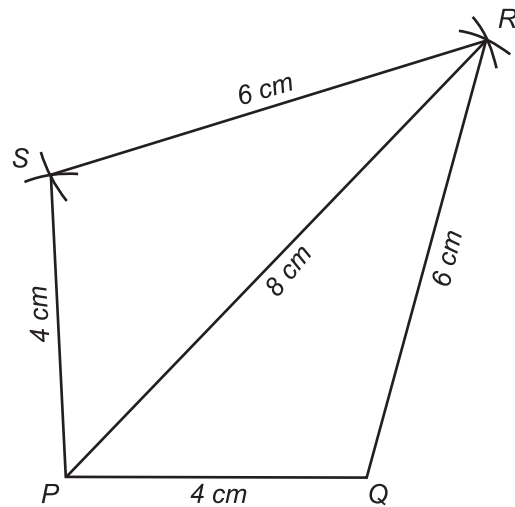

8.1.8 Construct a regular pentagon when a side is given

Example 11: Construct a regular pentagon $PQRST$ when $m\overline{PQ} = 4\text{ cm}$

Solution:

Steps of construction:

- i. Draw $m\overline{PQ} = 4\text{ cm}$.
- ii. Construct $m\angle P = m\angle Q = 108^\circ$.

[NOTE: Each interior angle of a regular pentagon is equal to 108° .]

- iii. Draw an arc with centre at P and radius 4 cm which intersects \overrightarrow{PX} at T .
- iv. Draw an arc with centre at Q and radius 4 cm which intersects \overrightarrow{QY} at R .
- v. Draw an arc with centre at R and radius 4 cm .
- vi. Draw an arc with centre at T and radius 4 cm . It intersects the arc drawn from point R at the point S .

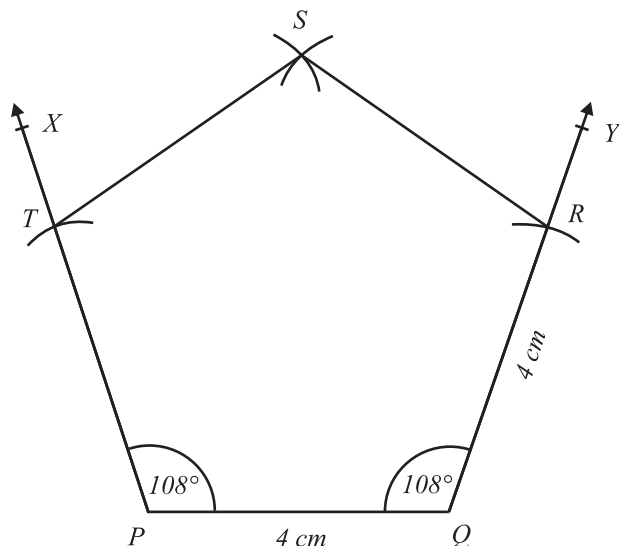

- vii. Join R with S and T with S .
- Hence, $PQRST$ is the required regular pentagon.

8.1.9 Construct a regular hexagon when a side is given

Example 12:

Construct a regular hexagon $ABCDEF$ when $m\overline{AB} = 3\text{ cm}$

Solution:

Steps of construction:

- i. Draw a circle of radius 3 cm with centre at O .

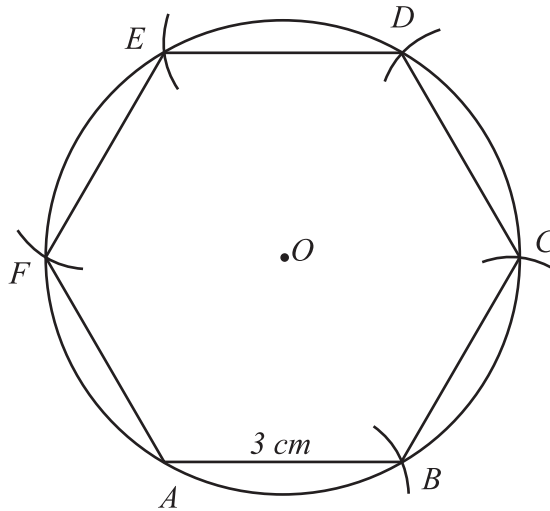

- ii. Take a point A on the circle, draw an arc on the circle with centre A and radius 3 cm . Label it as B .
- iii. Take B as the centre and radius 3 cm draw an arc on the circle, mark it as C .
- iv. Take C as the centre and radius 3 cm draw an arc on the circle, mark it as D .
- v. Take D as the centre and radius 3 cm draw an arc on the circle, mark it as E .
- vi. Take E as the centre and radius 3 cm draw an arc on the circle, mark it as F .
- vii. Join B with C , C with D , D with E , E with F and F with A .

Hence, $ABCDEF$ is the required regular hexagon.

Note: Each interior angle of a regular hexagon is equal to 120°

EXERCISE 8.1

1. Construct a square $ABCD$ when a diagonal $m\overline{AC} = 4.5\text{cm}$.
2. Construct a square $PQRS$ when its diagonal is 4cm more than its side.
3. Construct a square $PQRS$, when the sum of the diagonal and a side of the square is 8cm .
4. Construct a rectangle $ABCD$ when $m\overline{AB} = 4\text{cm}$ and $m\overline{BC} = 6\text{cm}$.
5. Construct a rectangle $ABCD$, when the $m\overline{AB} = 5.5\text{cm}$ and $m\overline{AC} = 8\text{cm}$
6. Construct a rhombus $KLMN$, when the $m\overline{KL} = 5\text{cm}$, $m\angle K = 75^\circ$
7. Construct a rhombus $STUV$, when $m\overline{ST} = 6\text{cm}$ and $m\overline{SU} = 9\text{cm}$
8. Construct a parallelogram $ABCD$ with diagonals 6cm and 8cm and the angle between them 70° .
9. Construct a parallelogram $DEFG$ where $m\overline{DE} = 5.5\text{cm}$, $m\overline{EF} = 6.5\text{cm}$ and $m\angle E = 60^\circ$.
10. Construct a kite $DEFG$ where $m\overline{DE} = 4\text{cm}$, $m\overline{EF} = 8\text{cm}$ and the length of the longer diagonal is $m\overline{DF} = 10\text{cm}$.
11. Construct a regular pentagon $ABCDE$, where $m\overline{AB} = 3.2\text{cm}$.
12. Construct a regular hexagon $STUVWX$, where $m\overline{ST} = 3\text{cm}$.

8.2 Construction of a Right angled triangle

(a) Construct a right angled triangle when hypotenuse and one side are given

Example 1: Construct a right angled triangle ABC , when $m\overline{AB} = 5\text{cm}$, $m\overline{AC} = 7\text{cm}$ and $m\angle B = 90^\circ$

Solution

Steps of construction:

- i. Draw $m\overline{AB} = 5\text{cm}$.
- ii. Construct $m\angle B = 90^\circ$. Draw \overrightarrow{BX}
- iii. Take A as the centre and radius 7cm . Draw an arc on intersecting \overrightarrow{BX} at C .
- iv. Join A with C .

Hence, ABC is the required right angled triangle.

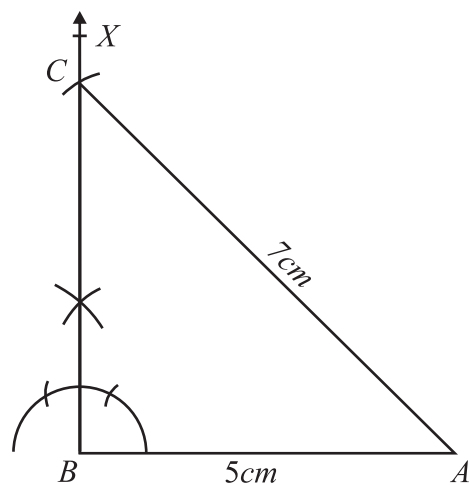

(b) Construct a right angled triangle when hypotenuse and the vertical height from its vertex to the hypotenuse are given

Example 2:

Construct a right angled triangle ABC , when hypotenuse $m\overline{BC} = 9\text{cm}$ and perpendicular from vertex A to \overline{BC} is 4cm .

Solution:

Steps of construction:

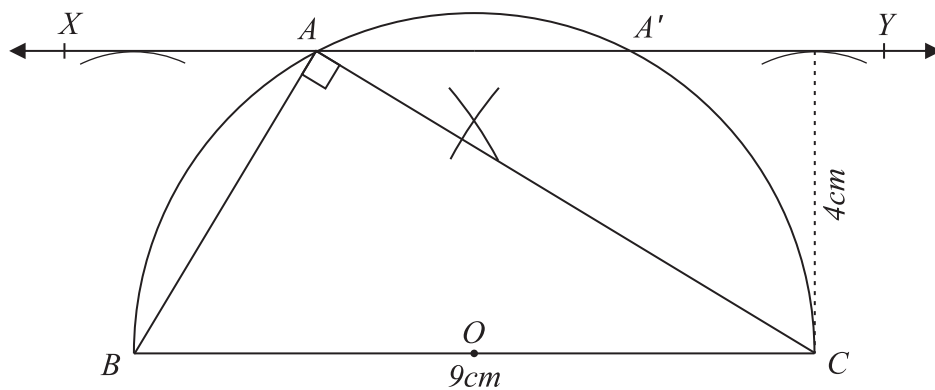

- i. Draw $m\overline{BC} = 9\text{cm}$.
- ii. Bisect the \overline{BC} at point O with the help of compass.
- iii. Draw a semi circle taking point O as centre.
- iv. Draw two arcs of radius 4cm taking points B and C as centre above \overline{BC} .
- v. Draw \overleftrightarrow{XY} touching the two arcs which intersects the semi circle at points A and A' .
- vi. Join A with B and C .

$\triangle ABC$ is the required right angled triangle at angle A .

EXERCISE 8.2

1. Construct following right angled triangles when:
 - a. Hypotenuse = 8.5cm and length of a side is 6cm .
 - b. Hypotenuse = 6cm and length of a side is 3cm .
 - c. Hypotenuse = 5cm and length of a side is 2.5cm .
2. Construct a right angled triangle ABC , when $m\overline{AB} = 4.5\text{cm}$, $m\overline{BC} = 5.5\text{cm}$ and $m\angle B = 90^\circ$.
3. Construct a right angled triangle PQR , when $m\overline{QR} = 8\text{cm}$, $m\overline{PQ} = 5\text{cm}$ and $m\angle Q = 90^\circ$.
4. Construct a right angled triangle LMN , when hypotenuse $m\overline{MN} = 8\text{cm}$ and perpendicular from vertex L to \overline{MN} is 3.5cm .

REVIEW EXERCISE 8

1. Four options are given against each statement. Encircle the correct one.
 - i. A polygon with sum of measure of interior angles equal to 360° is called:
 - (a) triangle (b) quadrilateral (c) pentagon (d) hexagon
 - ii. In a square, the diagonals:
 - (a) bisect each other (b) do not intersect
 - (c) are of unequal lengths (d) do not bisect each other
 - iii. In regular pentagon, the measure of an interior angle is:
 - (a) 100° (b) 108° (c) 116° (d) 124°
 - iv. In a rectangle, the diagonals:
 - (a) bisect each other (b) are perpendicular to each
 - (c) are parallel to each other (d) none of the above
 - v. In a rhombus, the diagonals:
 - (a) bisect the vertex angle (b) are of equal length
 - (b) are not perpendicular to each other (d) all of the above
 - vi. Square is a:
 - (a) pentagon (b) quadrilateral
 - (c) triangle (d) none of the above
 - vii. The measure of one interior angle of a regular hexagon is:
 - (a) 108° (b) 120° (c) 140° (d) 170°
 - viii. If the measure of three angles of a quadrilateral are 108° , 128° and 76° , then measure of its fourth angle is:
 - (a) 48° (b) 88° (c) 98° (d) 108°

2. Construct the following:
- Square $PQRS$ such that $m\overline{RS} = 4\text{cm}$.
 - Square $ABCD$ such that $m\overline{AC} = 3.5\text{cm}$.
 - Square $WXYZ$, when the difference of its diagonal and side is 5cm .
 - Square $PQRS$, when the sum of its diagonal and side is 8cm .
 - Rectangle $ABCD$ in which $m\overline{AB} = 5.5\text{cm}$ and $m\overline{BC} = 8\text{cm}$.
 - Rectangle $LMNO$, when $m\overline{LM} = 4\text{cm}$ and $m\overline{LN} = 6\text{cm}$
 - Rhombus $PQRS$, when $m\overline{PQ} = 5.5\text{cm}$ and $m\angle P = 75^\circ$.
 - Parallelogram $ABCD$ whose diagonals are 5cm and 9cm and the included angle is 80° .
 - Parallelogram $UVWX$ with sides $m\overline{UV} = 8\text{cm}$, $m\overline{UX} = 5\text{cm}$ and $m\angle U = 60^\circ$.
 - Kite $ABCD$ with $m\overline{AB} = 4\text{cm}$, $m\overline{BC} = 6\text{cm}$ and the length of the longer diagonal is $m\overline{AC} = 7\text{cm}$.
 - Regular pentagon $GHIJK$, when $m\overline{GH} = 4\text{cm}$.

SUMMARY

- Quadrilateral is a 4-sided polygon which has the sum of interior angles equal to 360° .
- Covering lines are non-parallel lines and these lines meet at a single point.
- Diagonals of a rectangle, a square, a parallelogram and a rhombus bisect each other.
- Diagonals of a square and a rhombus bisect each other at 90° .
- Diagonals of a square and a rectangle are of equal lengths.
- In a regular hexagon, the sum of measures of interior angles is 720° and the measure of each interior angle is 120° .
- In a regular pentagon, the sum of measures of interior angles is 540° and the measure of each interior angle is 108° .

Unit - 9



Areas and Volumes

After completion of this unit, the students will be able to:

- State the Pythagoras theorem and give its informal proof.
- Solve right angled triangles using Pythagoras theorem.
- State and apply Hero's formula to find the areas of triangular and quadrilateral regions.
- Find the surface area and volume of a sphere.
- Find the surface area and volume of a cone.
- Solve real life problems involving surface area and volume of sphere and cone.

9.1 PYTHAGORAS THEOREM

Pythagoras theorem is an important theorem in geometry. It is named after a **Greek Mathematician Pythagoras** 2500 years ago. He thought of inventing it when he observed a strange method adopted by Egyptians to measure the width of River Nile.

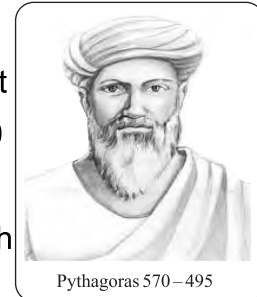

Pythagoras 570–495

They measure it with the help of a triangle formed by chains with the ratio among its sides as 3 : 4 : 5

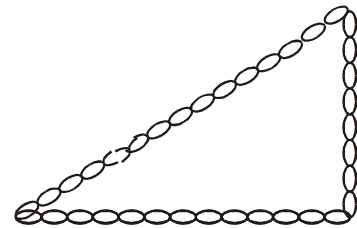

9.1.1 STATEMENT OF PYTHAGORAS THEOREM

In a right angled triangle ABC with $m\angle C = 90^\circ$ and a, b, c are opposite sides of the angles $\angle A, \angle B$ and $\angle C$ respectively then

$$a^2 + b^2 = c^2$$

$$(\text{Base})^2 + (\text{Altitude})^2 = (\text{Hypotenuse})^2$$

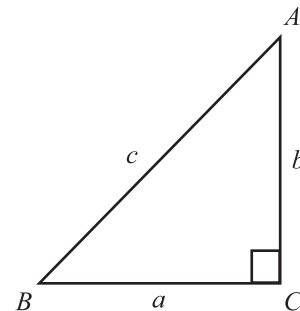

Remember that:

The hypotenuse of a right angled triangle is opposite side to the right angle. The adjacent horizontal side of the right angle is the base, and vertical side is the altitude.

INFORMAL PROOF OF PYTHAGORAS THEOREM

We shall prove it with the help of an activity.

Activity

Apparatus: Hard paper, pencil, ruler and pair of scissors.

Step I: Draw a right angled triangle ABC with sides a, b and c , where

$$m\angle C = 90^\circ \text{ and } a : b : c = 3 : 4 : 5$$

Step II: Draw squares on sides a , b and c adjacent to the respective sides as shown in the figure.

Step III: Since $a : b : c = 3:4:5$, so divide the lengths of sides of the square a , b and c into 3, 4 and 5 strips of equal width as shown in the figure.

Step IV: Shade the strips as shown in the figure.

Step V: Now cut the square into strips of side b with the help of a pair of scissors.

Step VI: Place the square of side " a " in the middle and the strips of the square side " b " on the square side " c " as shown in the figure.

We can observe that the area of the square of side " c " is equal to the total area of the square of side " b " and the square of side " a ".

Hence it is proved that:

$$a^2 + b^2 = c^2$$

$$(\text{Base})^2 + (\text{Altitude})^2 = (\text{Hypotenuse})^2$$

9.1.2 Solution of Right Angled Triangle through Pythagoras Theorem

Pythagoras theorem is usually applied for finding out the length of the third side of a right angled triangle while the lengths of two sides are known.

If " c " is the side opposite to the right angle, then

$$c^2 = a^2 + b^2$$

$$\text{or } a^2 = c^2 - b^2$$

$$\text{or } b^2 = c^2 - a^2$$

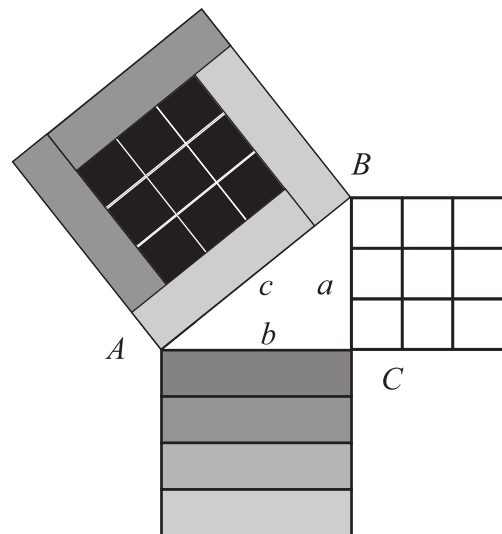

Example 1: In the given figure of triangle ABC , find the length of side AB .

Solution: Let $\overline{mAB} = x$

By Pythagoras theorem

$$c^2 = a^2 + b^2, m\angle C = 90^\circ$$

Here $c = x, a = 5\text{cm}, b = 12\text{cm}$

$$\begin{aligned} \therefore x^2 &= 5^2 + (12)^2 \\ &= 25 + 144 \end{aligned}$$

$$x^2 = 169$$

$$x = 13\text{cm}$$

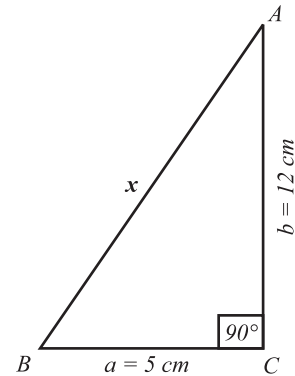

So, $\overline{mAB} = 13\text{cm}$

Example 2: The length and width of a rectangle are 8cm and 6cm respectively. Find the length of its diagonals.

Solution: Let $ABCD$ be the rectangle

and let $\overline{mBD} = x\text{cm}$.

In right angled triangle BCD

$m\angle C = 90^\circ$, Base = $\overline{mBC} = 8\text{cm}$

Altitude = $\overline{mCD} = 6\text{cm}$

Hypotenuse = $\overline{mBD} = x\text{cm}$

By Pythagoras theorem

$$x^2 = 8^2 + 6^2 = 64 + 36 = 100$$

$$x = 10\text{cm} \text{ or } \overline{mBD} = 10\text{cm}$$

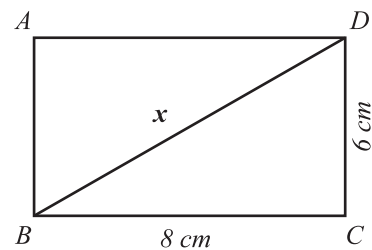

Since, the two diagonals of a rectangle are equal in length, so $\overline{mAC} = 10\text{cm}$.

Example 3: A ladder 2.5m long is placed against a wall. If its upper end reaches the height of 2m along the wall, then find the distance of the foot of the ladder from the wall.

Solution: Let x be the distance of the wall from the foot of the ladder.

Then by Pythagoras theorem $c^2 = a^2 + b^2$, $m\angle C = 90^\circ$

Here $c = 2.5m$, $a = x$, $b = 2m$

As $a^2 = c^2 - b^2$

$\therefore x^2 = (2.5)^2 - (2)^2 = 6.25 - 4$

or $x^2 = 2.25$

$x = 1.5m$

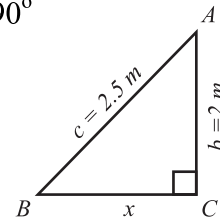

Example 4: Find the area of a rectangular field whose length is 20m and the length of its diagonal is 25m.

Solution: Let us take right angled triangle ABC, then by Pythagoras theorem:

$b^2 = a^2 + c^2$, $m\angle B = 90^\circ$

Here $b = 25m$, $a = 20m$

Let $c = xm$

$(25)^2 = x^2 + (20)^2$

$x^2 = (25)^2 - (20)^2 = 625 - 400 = 225$

$x^2 = 225 \Rightarrow x = 15m \Rightarrow x = 15m$

Width of the rectangle = 15m

Length of the rectangle = 20m

Thus, area of the rectangular field = $20 \times 15 = 300m^2$

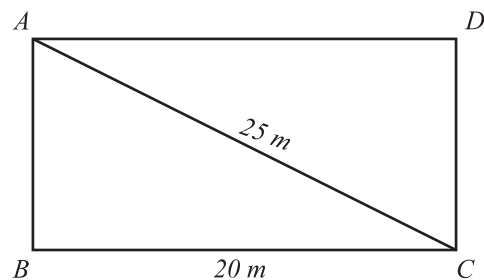

EXERCISE 9.1

1. In the right angled triangles (not drawn to scale), measurements (in cm) of two of the sides are indicated in the figures. Find the value of x in each case.

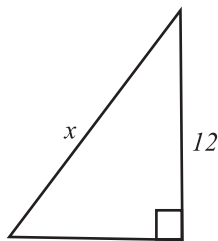

(i)

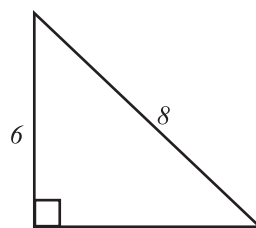

(ii)

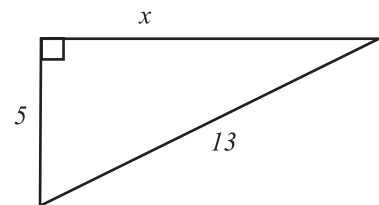

(iii)

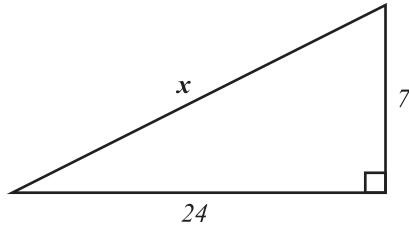

(iv)

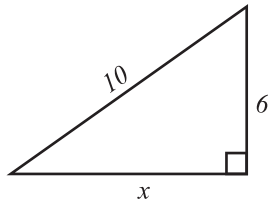

(v)

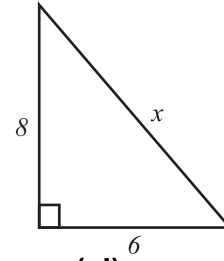

(vi)

2. In an isosceles right angled triangle, the square of the hypotenuse is 98cm^2 . Find the length of the congruent sides.
3. A ladder 10m long is made to rest against a wall. Its lower end touches the ground at a distance of 6m from the wall. At what height above the ground the upper end of the ladder rests against the wall?
4. In triangle ABC , right angle is at point C , $m\overline{BC} = 2.1\text{cm}$ and $m\overline{AC} = 7.2\text{cm}$. What is the length of \overline{AB} ?

5. In the given figure prove that:

$$a^2 - x^2 = b^2 - y^2$$

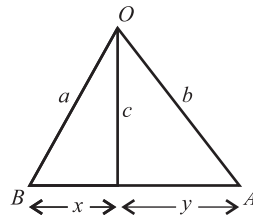

6. The shadow of a pole measured from the foot of the pole is 2.8m long. If the distance from the tip of the shadow to the tip of the pole is 10.5m then find the length of the pole.
7. If a, b, c are the lengths of the sides of a triangle ABC . Then tell which of the following triangles are not right angled triangles. Any of $\angle A, \angle B$ and $\angle C$ may be a right angle.

(i) $a = 6, b = 5, c = 7$

(ii) $a = 8, b = 9, c =$

(iii) $a = 12, b = 5, c = 13$

8. In a right angled triangle ABC with hypotenuse c and sides a and b . Find the unknown length.

(i) $a = 60\text{cm}, c = 61\text{cm}, b = ?$

(ii) $a = \frac{5}{12}\text{cm}, c = \frac{13}{12}\text{cm}, b = ?$

(iii) $a = 2.4\text{m}, c = 2.6\text{m}, b = ?$

(iv) $b = 10\text{m}, a = 4\text{m}, c = ?$

(v) $b = 5\text{dm}, a = 5, c = ?$

(vi) $c = 10, b = 5, a = ?$

9. The front of a house is in the shape of an equilateral triangle with the measure of one side is $10m$. Find the height of the house.

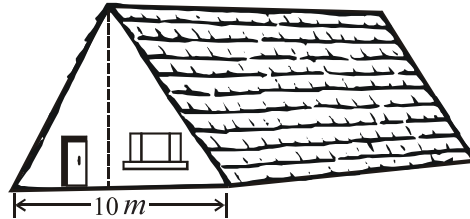

9.2 HERO'S FORMULA

In previous classes, we have learnt to find the area of right triangular regions. There are many methods for finding the areas of triangular regions. One of them is Hero's formula.

The formula was deduced by a **Greek Mathematician HERON OF ALEXANDRIA** and is named after him as **Hero's Formula**.

This formula is applied when the lengths of all sides of a triangle are known.

9.2.1 Statement of Hero's Formula

If a, b, c are the lengths of a triangle ABC , then the area of the triangle ABC denoted as \triangle is given by

$$\triangle = \quad \text{where } s = \frac{a+b+c}{2}$$

• Finding the Areas of Triangular and Quadrilateral Regions

Example 1: Find the area of a triangle while the lengths of its sides are $14cm$, $21cm$ and $25cm$ respectively.

Solution:

$$\text{Let } a = 14cm, \quad b = 21cm \quad \text{and} \quad c = 25cm$$

By Hero's Formula

$$\triangle = \quad \text{where } s = \frac{a+b+c}{2}$$

$$\text{Now } s = \frac{14 + 21 + 25}{2} = \frac{60}{2} = 30$$

$$a = 14cm, \quad b = 21cm, \quad c = 25cm, \quad s = 30$$

$$\therefore \triangle ABC =$$

$$\triangle ABC = \quad = \sqrt{5 \times 6 \times 4 \times 4 \times 3 \times 3 \times 5}$$

$$= \quad \text{and } = 3 \times 4 \times 5$$

$$\triangle ABC = 60 \quad cm^2$$

Example 2: Find the area of an isosceles triangle ABC in which

$$\overline{mAB} = \overline{mAC} = 6\text{ cm} \text{ and } \overline{mBC} = 8\text{ cm}.$$

Solution: Let a, b, c the sides opposite to the vertices A, B and C respectively.

Then $a = 8\text{ cm}, b = 6\text{ cm}$ and $c = 6\text{ cm}$

$$s = \frac{a+b+c}{2}$$

or $s = \frac{8+6+6}{2} = \frac{20}{2} = 10\text{ cm}$

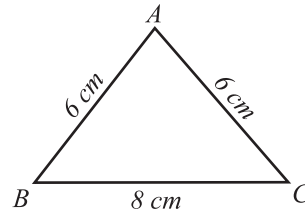

$$\begin{aligned} \therefore \triangle ABC &= \\ &= \\ &= \\ &= 2 \times 4 \\ &= 8 \text{ cm}^2. \end{aligned}$$

• **Finding the Area of a Quadrilateral Region with the help of Hero’s Formula**

Since any of the diagonals of a quadrilateral region separates it into two triangular regions so the area of the two triangles will be calculated by Hero’s formula. Then these areas of two triangles are added to get the area of the quadrilateral.

Example 3: Find the area of quadrilateral $ABCD$ in which $\overline{mAB} = 12\text{ cm},$
 $\overline{mBC} = 17\text{ cm}, \overline{mCD} = 22\text{ cm}, \overline{mDA} = 25\text{ cm}$ and $\overline{mBD} = 31\text{ cm}$

Solution: Area of the quadrilateral $ABCD = \triangle ABD + \triangle BCD$

For $\triangle ABD$

$$s = \frac{12 + 31 + 25}{2} = \frac{68}{2} = 34\text{ cm}$$

$$\begin{aligned} \therefore \triangle ABD &= \\ &= \\ &= \\ &= 2 \times 3 \\ &= 6 \times 23.69 \\ &= 142.14 \text{ cm}^2 \text{ (approx)} \end{aligned}$$

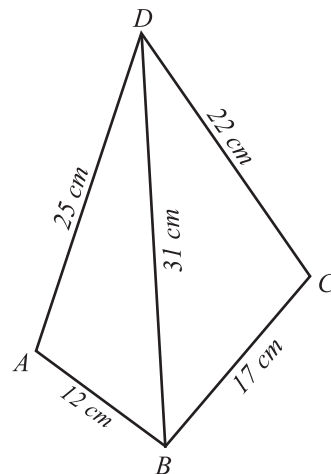

$$\begin{aligned} \text{For } \triangle BCD \quad s &= \frac{17 + 22 + 31}{2} \\ &= \frac{70}{2} = 35 \text{ cm} \end{aligned}$$

$$\begin{aligned} \therefore \triangle BCD &= \\ &= \\ &= 6 \qquad = 6 \times 30.16 \\ &= 180.96 \text{ cm}^2 \text{ (approx)} \end{aligned}$$

$$\begin{aligned} \therefore \text{Area of the quadrilateral } ABCD &= \triangle ABD + \triangle BCD \\ &= 142.14 + 180.96 \\ &= 323.10 \text{ cm}^2 \text{ (approx)} \end{aligned}$$

EXERCISE 9.2

- The lengths of the sides of a triangle are $60m, 153m$ and $111m$. Find the area of the triangle.
- Find the area of triangles, when lengths of the sides are given below:
 - $13cm, 14cm, 15cm$
 - $5cm, 12cm, 13cm$
 - $103cm, 115cm, 13cm$
- Find the missing elements as required in each of the following with the help of Hero's formula.
 - $a = 5m, \quad b = 7m, \quad s = 9m, \quad c = \text{-----}, \Delta ABC = \text{-----}$
 - $a = 10m, \quad b = 8m, \quad s = 12m, \quad c = \text{-----}, \Delta ABC = \text{-----}$
 - $a = 3m, \quad s = 9.5m, \quad c = 9m, \quad b = \text{-----}, \Delta ABC = \text{-----}$
 - $a = 3.5m, \quad b = 2.5m, \quad c = 4.5m, \quad s = \text{-----}, \Delta ABC = \text{-----}$
- Find the area of the quadrilateral region $ABCD$. All measurements are in cm .

- $a = 19, \quad b = 12, \quad c = 15, \quad d = 20$ and $e = 23$
- $a = 12, \quad b = 14, \quad c = 17, \quad d = 19$ and $e = 21$
- $a = 2, \quad b = 2.5, \quad c = 3, \quad d = 1.5$ and $e = 3.5$
- $a = 1.7, \quad b = 1, \quad c = 1.3, \quad d = 1.8$ and $e = 2.1$

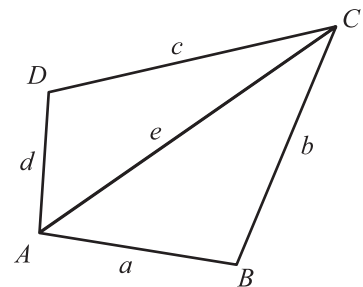

5. The given figure, $ABCD$ is of a rectangle of sides 8cm and 12cm . E and F are the mid-points of the sides BC and AD respectively. By using Pythagoras Theorem and Hero's Formula, find:
- The areas of the triangles ABE and FDC .
 - The area of the parallelogram $AECF$.

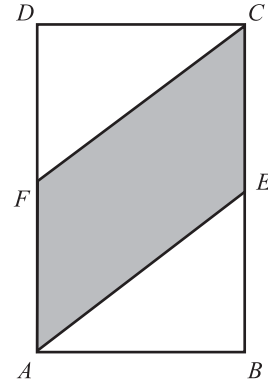

9.3 SURFACE AREA AND VOLUME OF SPHERE

A sphere is a solid bounded by a single curved surface such that all the points on its outer surface are at an equal distance from a fixed point inside the sphere.

The fixed point is called its **Centre**. The distance from centre to its outer surface is called its **Radius**. In the given figure the point O is its Centre.

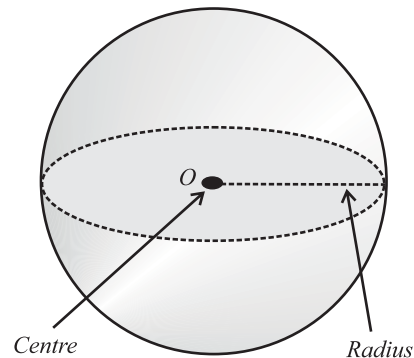

The measurement of line segments \overline{OA} , \overline{OB} , \overline{OC} and \overline{OD} are all its radii and are equal in length.

Cricket ball is the example of a sphere.

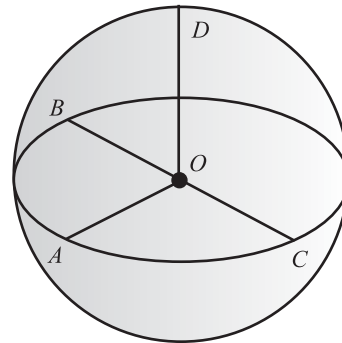

9.3.1 Finding the Surface Area and Volume of a Sphere

- Surface Area of a Sphere**

A famous scientist **Archimedes** discovered that the surface area of a sphere is equal to the curved surface area of the cylinder whose radius is equal to the radius of the sphere and its height is equal to the diameter of the sphere (i.e. twice the radius).

Let the radius of the sphere = r

Radius of the cylinder = r

Height of the cylinder $h = 2r$

Curved surface area of cylinder = $2 \pi r h$

Surface area of sphere = $2 \pi r(2r) \quad \because h = 2r$
 $= 4 \pi r^2$

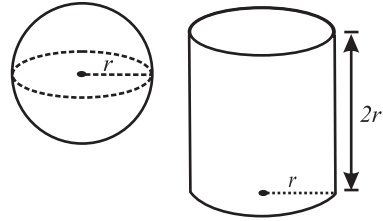

Example 1: Find the surface area of a sphere whose radius is 21cm ($\pi = \frac{22}{7}$)

Solution: Surface area of a sphere of radius $r = 4 \pi r^2$

Where $r = 21\text{cm}$, $\pi = \frac{22}{7}$

$$\begin{aligned} \text{Required surface area} = S &= 4 \times \frac{22}{7} \times (21)^2 \\ &= 4 \times \frac{22}{7} \times 21 \times 21 \\ S &= 5544\text{cm}^2 \end{aligned}$$

Example 2: Find the radius of a sphere if the area of its surface is 6.16m^2 .

Solution: Let the area of the curved surface = A

Radius = r

$$A = 4 \pi r^2$$

It is given that $A = 6.16\text{m}^2$, $\pi = \frac{22}{7}$

$$4 \pi r^2 = 6.16\text{m}^2$$

$$\text{or } r^2 = \frac{6.16}{4 \pi}$$

$$r^2 = \frac{6.16 \times 7}{4 \times 22}$$

$$r^2 = 0.49\text{m}^2$$

$$r =$$

$$\text{or } r = 0.7\text{m}$$

• Volume of a Sphere

Volume of a sphere $V =$ Two third of the volume of the cylinder
 (with radius r) (with radius r and height $2r$)

$$V = \frac{2}{3} \times \pi r^2 \times 2r = \frac{4}{3} \pi r^3$$

$$\therefore \text{Volume of a sphere with radius } r \quad V = \frac{4}{3} \pi r^3$$

Example 3: How many litres of water a spherical tank can contain whose radius is $1.4m$?

Solution: Volume of a sphere with radius r is given by

$$V = \frac{4}{3} \pi r^3, \quad r = 1.4m$$

$$V = \frac{4}{3} \times \frac{22}{7} \times (1.4)^3 \quad (\because 1m^3 = 1000 \ell)$$

$$\begin{aligned} V &= \frac{4}{3} \times \frac{22}{7} \times 1.4 \times 1.4 \times 1.4 \\ &= 11.499m^3 = 11499 \ell \end{aligned}$$

Example 4: Find the volume of a sphere, the surface area of which is $2464cm^2$.

Solution: Surface area of a sphere of radius r is $A = 4\pi r^2$.

Let r be the radius of the given sphere, then

$$4\pi r^2 = 2464cm^2$$

$$\begin{aligned} \text{or} \quad r^2 &= \frac{2464}{4\pi} \\ &= \frac{2464 \times 7}{4 \times 22} \end{aligned}$$

$$r^2 = 196$$

$$\text{or} \quad r = 14cm$$

Let V be the volume of the sphere, then

$$\begin{aligned} V &= \frac{4}{3} \pi r^3 \\ &= \frac{4}{3} \pi \times (14)^3 = \frac{4}{3} \times \frac{22}{7} \times (14)^3 \\ &= \frac{34496}{3} = 11498.66cm^3 \quad (\text{approx}) \end{aligned}$$

EXERCISE 9.3

1. Find the curved surface area of the spheres whose radii are given below (taking $\pi = \frac{22}{7}$).

(i) $r = 3.5cm$ (ii) $r = 2.8m$ (iii) $0.21m$

2. Find the radius of a sphere if its area is given by

(i) $154m^2$ (ii) $231m^2$ (iii) $308m^2$

3. Find the volume of a sphere of radius " r " if r is given by

(i) $5.8cm$ (ii) $8.7cm$ (iii) $7cm$ (iv) $3.4m$

4. Find the radius and volume of each of the following spheres whose surface areas are given below:

(i) $201\frac{1}{7} \text{ cm}^2$ (ii) 2.464 cm^2 (iii) 616 m^2

5. A spherical tank is of radius 7.7 m . How many litres of water can it contain, when $1000 \text{ cm}^3 = 1 \text{ litre}$.

6. The radius of sphere A is twice that of a sphere B . Find:

- (i) The ratio among their surface areas.
- (ii) The ratio among their volumes.

7. The surface area of a sphere is $576\pi \text{ cm}^2$. What will be its volume? If it is melted, how many small spheres of diameter 1 cm can be made out of it?

8. A solid copper sphere of radius 3 cm is melted and electric wire of diameter 0.4 cm is made out of the copper obtained. Find the length of the wire.

9.3.2. Finding the Surface Area and Volume of a Cone

The given figure is of a cone.

Conical solids consist of two parts:

- (i) Circular base.
- (ii) Curved surface.

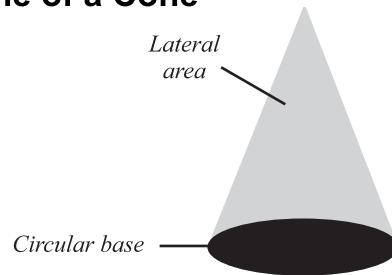

There are 5 elements of cone as shown in the figure given on the right side.

- (i) vertex (the point V)
- (ii) radius (\overline{OC})
- (iii) height (\overline{OV})
- (iv) slant height (\overline{CV}) or (\overline{AV})
- (v) centre (the point O)

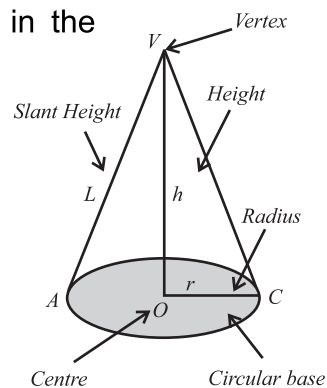

The line joining the vertex to the centre of the cone is perpendicular to the radial segment of the cone.

• **Finding the Surface Area of a Cone**

We know that the area of the circular base of a cone whose radius r , is given

$$\text{Base area} = \pi r^2$$

Curved surface area of a cone = $\pi r \ell$ (where r is radius and ℓ is the slant height)

Total surface area of a cone = Base area + curved surface area

$$= \pi r^2 + \pi r \ell$$

$$= \pi r(r + \ell)$$

Example 5: The radius of the base of a cone is 3cm and the height is 4cm . Find its slant height.

Solution: We know that $\ell =$

Where $r = 3\text{cm}$ and $h = 4\text{cm}$

$$\therefore \ell = \quad =$$

=

$$\ell = 5\text{cm}$$

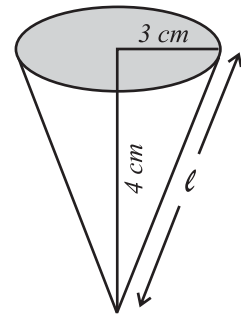

Example 6: The radius of a cone's base is 6cm , slant height is 10cm . Find its total surface area of the cone.

Solution: Radius (r) = 6cm , $\ell = 10\text{cm}$

$$\begin{aligned} \text{Total surface area} &= \pi r (\ell + r) \\ &= \frac{22}{7} (6) (10 + 6) = \frac{22}{7} \times 96 \\ &= \frac{2112}{7} \text{ cm}^2 = 301 \frac{5}{7} \end{aligned}$$

$$\text{Surface area of a cone} = 301 \frac{5}{7} \text{ cm}^2$$

Example 7: The base area of a cone is $254 \frac{4}{7} \text{ cm}^2$ and slant height is 15cm . Find its height.

Solution: Base area = $\pi r^2 = 254 \frac{4}{7} \text{ cm}^2$

$$\begin{aligned} r^2 &= \frac{1782}{7} \times \frac{7}{22} \\ &= 81 \text{ cm}^2 \end{aligned}$$

$$r = 9\text{cm}$$

$$\text{Slant height} = \ell = 15\text{cm}$$

$$\text{Height} = h =$$

$$=$$

• Finding Volume of a Cone

Let us find the volume of a cone through an activity.

- Activity:** Apparatus (i) One sided open hollow cylinder with radius r .
units height h units (Take r and h as convenient).
(ii) A hollow cone with radius r and height h .
(i.e.,) bases and heights of both should be congruent.
(iii) Sand

Step I: Fill up the cone with sand and pour it into the cylinder.

Step II: Fill it up again and pour it into the cylinder.

Step III: Fill it up again and pour it into the cylinder.

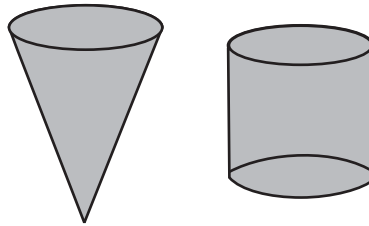

We know that:

$$\begin{array}{l} 3 \text{ times volume of a cone} \\ \text{(with radius } r \text{ and height } h) \end{array} = \begin{array}{l} \text{Volume of the cylinder} \\ \text{(with radius } r \text{ and height } h) \end{array}$$

Since we know that the volume of a cylinder with radius r is $\pi r^2 h$.

$$\begin{aligned} \therefore \text{Volume of a cone} &= \frac{1}{3} \pi r^2 h \\ &\text{(radius } r \text{ and height } h) \\ &= \frac{1}{3} (\text{area of the base} \times \text{height}) \end{aligned}$$

Example 8: How much sand can a conical container hold whose height is 3.5m and radius is 3m , while 1m^3 space contains 100kg of sand?

Solution: Radius (r) = 3m , $h = 3.5\text{m}$

$$\begin{aligned} \text{Volume of the container} &= \frac{1}{3} \times \frac{22}{7} \times 3^2 \times 3.5 \\ &= 22 \times 3 \times 0.5 \\ &= 33\text{m}^3 \end{aligned}$$

$$\text{Sand in } 1\text{m}^3 = 100\text{kg}$$

$$\text{Sand in } 33\text{m}^3 = 3300\text{kg}$$

Example 9: A tent in the form of a cone is $5m$ high and its base is of radius $12m$. Find:

- (i) The area of the canvas used to make the tent.
 (ii) The volume of the air space in it.

Solution: (i) Area of the curved surface of the cone

$$\begin{aligned} &= \pi r \ell \\ &= 12 \pi \times \sqrt{(5)^2 + (12)^2} \\ &= 12 \pi \times \sqrt{25 + 144} \\ &= 12 \pi \times \sqrt{169} = 12 \pi \times 13 \\ &= 3.14 \times 156 \quad (\text{Taking } \pi = 3.14 \text{ approx}) \\ &= 489.84m^2 \quad (\text{approx}) \end{aligned}$$

\therefore The area of the canvas required for the tent is $489.84m^2$.

(ii) Volume of the cone $= \frac{1}{3} \pi r^2 h$

$$\begin{aligned} &= \frac{1}{3} \pi \times 12^2 \times 5 \\ &= 3.14 \times 4 \times 5 \times 12 \\ &= 3.14 \times 240 \\ &= 753.60m^3 \end{aligned}$$

\therefore The volume of air space in the tent $= 753.60m^3$.

Example 10: The radius and height of a metal cone are respectively $2.4cm$ and $9.6cm$. It is melted and re-casted into a sphere. Find the radius of the sphere.

Solution: Let the volume of the cone be $= V_1$

Let the volume of the sphere be $= V_2$

$$V_1 = \frac{1}{3} \pi r^2 h$$

Here

$$r = 2.4cm$$

and

$$h = 9.6cm$$

Let the radius of the sphere to be formed $= R$

Then

$$V_2 = \frac{4}{3} \pi R^3$$

Now

$$V_2 = V_1$$

$$\frac{4}{3} \pi R^3 = \frac{1}{3} \pi r^2 h$$

$$4R^3 = r^2 h$$

$$R^3 = \frac{(2.4)^2 \times 9.6}{4} = (2.4)^3$$

$$R = 2.4cm$$

EXERCISE 9.4

1. Write down the missing element of cones for which (all lengths are in cm)

	r	h	ℓ	Curved surface area	Base area	Total surface area
(i)	–	8	10	–	–	–
(ii)	3	4	–	–	–	–
(iii)	9	–	25	–	–	–
(iv)	–	–	–	–	154 cm^2	374 cm^2

2. Find the Volume of the Cone if:
- (i) $r = 3\text{ cm}$, $h = 4\text{ cm}$ (ii) $r = 7\text{ cm}$, $h = 10\text{ cm}$
 (iii) $r = 5\text{ cm}$, $\ell = 7\text{ cm}$ (iv) $h = 5\text{ cm}$, $\ell = 8\text{ cm}$
3. A conical cup is full of ice-cream. What will be the quantity of the ice-cream, if the radius and height of the cone are 4 cm and 5 cm respectively?
4. What will be the total surface area of a solid cone of height 4 cm and radius 3 cm ?
5. The area of the base of cone is 38.50 cm^2 . If its height is three times the radius of the base, find its volume.
6. A conical tent is 8.4 m high and its base is of 54 dm radius. It is to be used to accommodate scouts. How many scouts can be accommodated in the tent if each scout requires 5.832 m^3 of air?

REVIEW EXERCISE 9

1. Four options are given against each statement. Encircle the correct one.
- i. If in a right angled triangle ABC , $m\angle C = 90^\circ$, then ' c ' is called:
- (a) base (b) hypotenuse
 (c) perpendicular (d) vertex
- ii. If in a right angled triangle ABC , $m\angle C = 90^\circ$ and $\angle A$ is a base angle, then ' b ' is called:
- (a) base (b) hypotenuse
 (c) perpendicular (d) vertex
- iii. If in a right angled triangle ABC , $m\angle C = 90^\circ$ and $\angle A$ is a base angle, then ' a ' is called:
- (a) base (b) hypotenuse
 (c) perpendicular (d) vertex

- iv In a right angled triangle the side opposite to the right angle is called:
- (a) perpendicular (b) base
(c) hypotenuse (d) right angle
- v. The area of a right angled triangle whose base is 3 cm and height is $6\text{ cm} = ?$
- (a) 9 cm^2 (b) 16 cm^2
(c) 25 cm^2 (d) 64 cm^2
- vi Hero's formula for area of a triangle is:
- (a) (b)
(c) (d)
2. Write short answers of the following questions.
- (i) State Pythagoras theorem.
(ii) Write Hero's formula.
(iii) Write formula of surface area of a sphere.
(iv) Write the formula of volume of a cone.
3. (i) Find the volume of a sphere when radius is 3.2 cm .
(ii) Find the volume of the cone if $r = 3\text{ cm}$ and $h = 4\text{ cm}$.
(iii) Find the area of a triangle whose sides are 4 cm , 5 cm and 8 cm .

SUMMARY

- In a right angled triangle, the square of the hypotenuse is equal to the sum of the squares of the other two sides.
- Hero's formula for the area of a triangle with sides of length a , b , c is

$$\Delta = \sqrt{s(s-a)(s-b)(s-c)}, \text{ where } s =$$

- Surface area of a sphere of radius $r = 4\pi r^2$.
- Volume of a sphere of radius $r =$
- Total surface area of a cone $= \pi r(r + \ell)$.
- Volume of the cone Area of base of cone vertical height of cone



After completion of this unit, the students will be able to:

- Define demonstrative geometry.
- Describe the basics of reasoning.
- Describe the types of assumptions (axioms and postulates).
- Describe parts of propositions.
- Describe the meaning of a geometrical theorem, corollary and converse of a theorem.
- Prove the following theorems along with corollaries and apply them to solve appropriate problems.
- If a straight line stands on another straight line, the sum of measures of two angles so formed is equal to two right angles.
- If the sum of measures of two adjacent angles is equal to two right angles, the external arms of the angles are in a straight line.
- If two lines intersect each other, then the opposite vertical angles are congruent.
- If two sides of a triangle are congruent, then the angles opposite these sides are congruent.
- The sum of measures of the three angles of a triangle is 180° .

10.1 Define Demonstrative Geometry

Demonstrative geometry is a branch of mathematics in which theorems on geometry are proved through logical reasoning. It demonstrates the truth of mathematical statements concerning geometric figures.

10.1.1 Basics of reasoning

Basics of reasoning in mathematics are:

- **Basic Concepts:** Some concepts are accepted without defining them for example point, line or plane.
- **Assumptions:** Some statements are accepted true without proofs. These are called basic assumptions.

10.1.2 Types of Assumptions

Axioms:

An axiom is a self-evident truth which needs no proof or demonstration and can be taken for granted.

Examples of Axioms

- i. A whole is always greater than its part or a part cannot be equal to the whole.
- ii. Things which are equal to the same thing are equal.
- iii. If equals be subtracted from equals, the differences are equal.
- iv. Doubles and halves of equal are equal.

Postulates:

A postulate is that elementary statement which we have to assume while making a demonstration.

Examples of Postulates

- A straight line may be drawn from one point to any other point in the same plane.
- We can produce a finite straight line to any length in a straight line in either direction.
- We can cut off a straight line of any length from a given straight line either from it or by producing it.
- The magnitude of an angle does not depend upon the length of its arms.

10.1.3 Parts of Propositions

A proposition is a declarative sentence that is either true or false. The various parts of propositions are:

- i. **Enunciation:** It is the statement of a geometrical truth which we are going to prove.
- ii. **Given:** For the sake of convenience and clarity, we first of all put down what is given to us or what is assumed.
- iii. **To Prove:** In this part, we put down what we are going to prove or establish.
- iv. **Construction:** In this part of the proposition, we note down all the additional lines or figures which must be drawn so that, we may be able to arrive at the required result.
- v. **Proof:** In this part, we establish the truth with a suitable line of reasoning.

10.1.4 Describe the meaning of a Geometrical Theorem, Corollary and Converse of a Theorem

Geometrical Theorem:

A theorem is that kind of proposition in which we establish a geometrical truth by means of reasoning with the help of a geometrical figure.

Examples of Theorems

- i. The sum of the interior angles of a triangle is 180° .
- ii. If two angles of a triangle are congruent, the sides opposite these angles are congruent.

Corollary:

A corollary is also a proposition, the truth of which can be immediately drawn from the theorem that has already been proved.

For example, a theorem in geometry is “The angles opposite two congruent sides of a triangle are also congruent”. A corollary to that statement is that in an equilateral triangle all angles are congruent.

Converse of theorem:

When the ‘Given’ of one proposition becomes the ‘To Prove’ of the other proposition and vice versa, the two propositions are called converse of each other.

For example the converse of Pythagoras theorem is “If the sum of the squares of two sides is equal to the square of the third side of the triangle, the triangle is a right triangle”.

10.2 Theorems

10.2.1 Prove the following Theorems along with Corollaries and apply them to solve Appropriate Problems.

Theorem 1:

If a straight line stands on another straight line, the sum of measures of two angles so formed is equal to two right angles.

Given: \overleftrightarrow{AB} is a straight line and \overrightarrow{OC} stands on it at point O .

To Prove:

$$m\angle AOC + m\angle BOC = 180^\circ$$

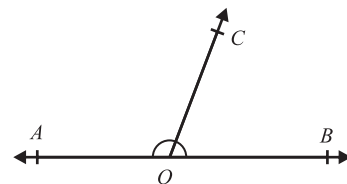

Proof

Statement	Reason
But, $m\angle AOC + m\angle BOC = m\angle AOB$	Angle addition postulate. -----(1)
$m\angle AOB = 180^\circ$	Straight angle -----(2)
$m\angle AOC + m\angle BOC = 180^\circ$	By (1) and (2)

Corollary:

If two straight lines intersect one another, the four angles so formed are equal to four right angles.

Example 1: Find x in the given figure.

Solution:

$$m\angle POY + m\angle QOY = x + 75^\circ = 180^\circ \text{ (By Theorem 1)}$$

$$x = 180^\circ - 75^\circ = 105^\circ$$

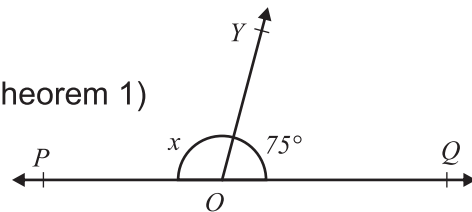

Theorem 2: If the sum of measures of two adjacent angles is equal to two right angles, the external arms of the angles are in a straight line.

Given: $m\angle POY$ and $m\angle QOY$ are adjacent angles and $m\angle POY + m\angle QOY = 180^\circ$

To prove:

and \overrightarrow{OX} are in a straight line. i.e., POQ is a straight line

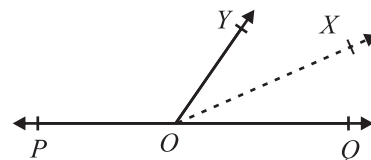

Construction:

Suppose \overleftrightarrow{POQ} is not a straight line then, draw a straight line \overleftrightarrow{POX} .

Proof:

Statement	Reason
\overleftrightarrow{POX} is a straight line.	Construction
$m\angle POY + m\angle YOX = 180^\circ$	\overleftrightarrow{OY} stands on \overleftrightarrow{POX} . -----(1)
$m\angle POY + m\angle QOY = 180^\circ$	Given -----(2)
$m\angle POY + m\angle YOX = m\angle POY + m\angle QOY$	By (1) and (2)
$\therefore m\angle YOX = m\angle QOY$	----- (3)
It is not possible.	\because part cannot be equal to the whole.
Thus our supposition is wrong.	----- (4)
Hence, \overleftrightarrow{POQ} is a straight line.	By (3) and (4)

Corollary 1: If two straight lines cut one another, the sum of the measures of the angles so formed is equal to four right angles.

Corollary 2: When any number of straight lines meets at a point, the sum of the consecutive angles so formed is equal to four right angles.

Theorem 3: If two lines intersect each other, then the opposite vertical angles are congruent.

Given: Let line XY intersects line PQ at point O .

To Prove:

$$\angle XOQ \cong \angle YOP$$

$$\angle YOQ \cong \angle XOP$$

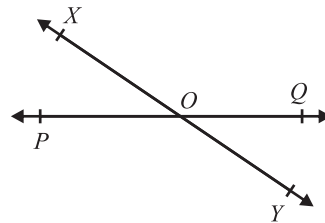

Proof:

Statement	Reason
$m\angle XOQ + m\angle QOY = 180^\circ$	\because XY is a straight line -----(1)
$m\angle QOY + m\angle YOP = 180^\circ$	\because PQ is a straight line -----(2)
$m\angle XOQ + m\angle QOY = m\angle QOY + m\angle YOP$	By (1) and (2)
Thus, $m\angle XOQ = m\angle YOP$	Subtracting $\angle QOY$ from both the sides.
So, $\angle XOQ \cong \angle YOP$	
Similarly, $\angle YOQ \cong \angle XOP$	

Example 2: Find “ a ” in the given figure.

Solution:

$$2a = 64^\circ \text{ (Vertically opposite angles)}$$

Thus, $a = 32^\circ$

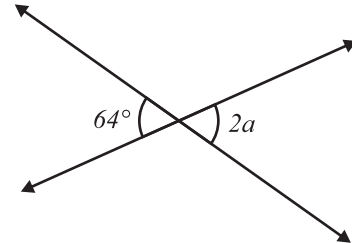

EXERCISE 10.1

1. Find the measure of the angles marked with letters

(i)

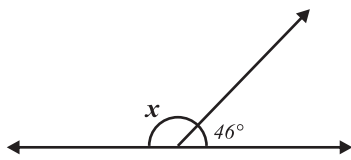

(ii)

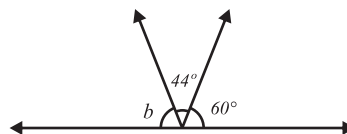

(iii)

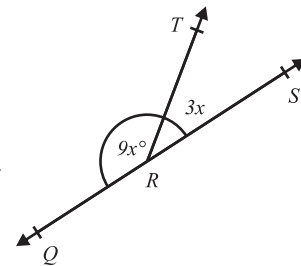

(iv)

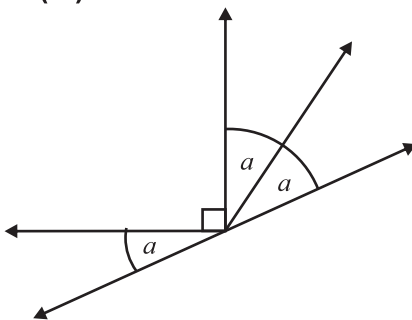

(v)

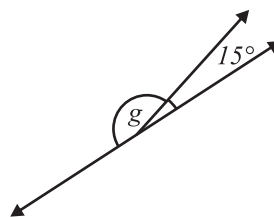

(vi)

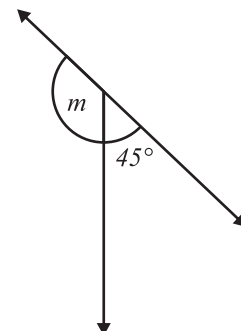

2. If a straight line makes a right angle on the straight line then prove that the other angle is also a right angle.
3. Three lines pass through a common point and divide the plane into 6 equal angles. Express the value of each angle in right angles, and in degrees.

Theorem 4

If two sides of a triangle are congruent, then the angles opposite these sides are congruent.

Given:

$$\text{In } \triangle ABC, \overline{AB} \cong \overline{AC}$$

To Prove:

$$\angle B \cong \angle C$$

Construction:

Draw the angle bisector of $\angle A$ which intersects \overline{BC} at point D .

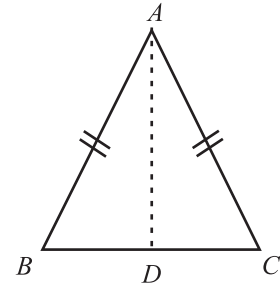

Proof:

Statement	Reason
Consider $\triangle ABD \leftrightarrow \triangle ACD$	
$\overline{AB} \cong \overline{AC}$	Given
$\angle BAD \cong \angle CAD$	Construction
$\overline{AD} \cong \overline{AD}$	Common arm to both angles
Thus, $\triangle ABD \cong \triangle ACD$	S.A.S theorem
Hence, $\angle B \cong \angle C$	Corresponding angles of congruent triangles

Corollary: In an equilateral triangle all angles are congruent.

Corollary: The bisector of the vertex angle of an isosceles triangle is also the perpendicular bisector of the base of the triangle.

Theorem 5

The sum of measures of the three angles of a triangle is 180° .

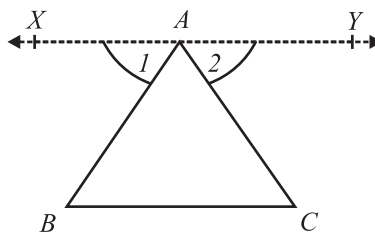

Given: $\triangle ABC$

To Prove:

$$m\angle BAC + m\angle B + m\angle C = m\angle 180^\circ$$

Construction:

Through point A , draw $\overline{XY} \parallel \overline{BC}$

Proof

Statement	Reason
$m\angle B = m\angle 1$ -----(1)	Alternate angles are congruent
$m\angle C = m\angle 2$ -----(2)	Alternate angles are congruent
Adding (1) and (2) $m\angle B + m\angle C = m\angle 1 + m\angle 2$	By (1) and (2)
$m\angle B + m\angle C + m\angle BAC = m\angle 1 + m\angle 2 + m\angle BAC$	Adding $m\angle BAC$ to both the sides.
$m\angle B + m\angle C + m\angle BAC = m\angle CAX + m\angle 2$ $= 180^\circ$	$\because m\angle 1 + m\angle BAC = m\angle CAX$ $\because m\angle CAX + m\angle 2 = 180^\circ$
Thus, $m\angle BAC + m\angle B + m\angle C = 180^\circ$	

Corollaries

- i. Each angle of an equilateral triangle is 60° .
- ii. In a right angled triangle, the acute angles are complementary.

EXERCISE 10.2

1. If $\Delta PQR \cong \Delta STU$ then, which sides and angles have equal measurements?
2. The pairs of triangles given below are congruent. By which theorem or postulate each pair of triangles in figures (a) through (d) can be proved congruent?

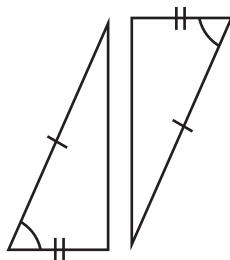

(a)

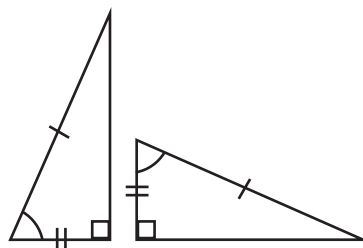

(b)

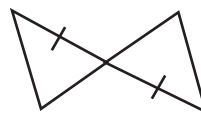

(c)

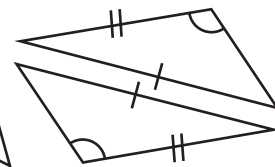

(d)

3. In an isosceles triangle the angle at the base is 45° . Find the angle opposite to the base.

4. If the arms of two angles are parallel and both the arms of each pair are in the same direction or in the opposite direction, then prove that these angles are congruent.
5. Find the measure of sides of triangle where $m\angle B = m\angle C$.

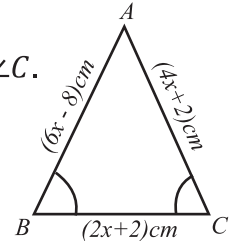

REVIEW EXERCISE 10

1. Four options are given below for each statement. Encircle the correct one.
 - i. A branch of mathematics in which theorems are proved through logical reasoning is called:

(a) algebra	(b) set theory
(c) logarithm	(d) demonstrative geometry
 - ii. The statements which are accepted true without proofs are called:

(a) basic assumptions	(b) theorems
(c) corollaries	(d) problems
 - iii. The elementary statement which we have to assume while making a demonstration is called:

(a) Postulate	(b) Theorem
(c) Problem	(d) Axiom
 - iv. A self-evident truth which needs no proof or demonstration and can be taken for granted is called:

(a) Postulate	(b) Theorem
(c) Problem	(d) Axiom
 - v. A starting point of reasoning is called:

(a) Problem	(b) Theorem
(c) Corollary	(d) Axiom
 - vi. A claim which could be seen to be true without any need for proof is:

(a) basic assumption	(b) theorem
(c) corollary	(d) problem

- vii. A supposition which is considered to be true with respect to a certain line of inquiry, without proof is:
- (a) Axiom (b) Theorem
(c) Corollary (d) Postulate
- viii. The statement of a geometrical truth which we are going to prove is called:
- (a) Enunciation (b) To Prove
(c) Given (d) Proof
- ix. A statement that can be demonstrated to be true by accepted mathematical operations and arguments is called:
- (a) Basic assumption (b) Theorem
(c) Corollary (d) Problem
- x. The result which can be inferred directly from the theorems is called:
- (a) basic assumption (b) theorem
(c) corollary (d) universal truth
2. Find the measure of the angles marked with letters.

(i)

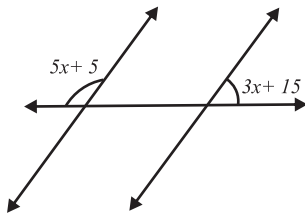

(ii)

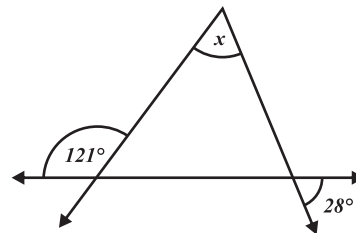

(iii)

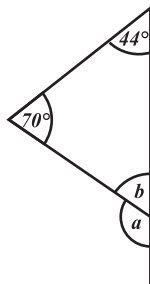

(iv)

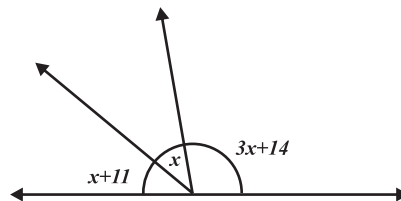

3. Prove the following:
- i. If two lines intersect each other and all four angles are equal, then each is a right angle.
- ii. The altitude to the base of an isosceles triangle bisects the base.

SUMMARY

- Demonstrative geometry is used to demonstrate the truth of mathematical statements concerning geometric figures.
- Demonstrative geometry is a branch of mathematics in which theorems on geometry are proved through logical reasoning.
- The statements which are accepted true without proofs are called basic assumptions.
- An axiom is a self-evident truth which needs no proof or demonstration and can be taken for granted.
- A postulate is that elementary statement which we have to assume while making a demonstration
- A proposition is a declarative sentence that is either true or false. There are three parts to any proposition:
- Enunciation is the statement of a geometrical truth which we are going to prove.
- Given: For the sake of convenience and clarity, we first of all put down what is given to us or what is assumed.
- To Prove: In this, we put down what we are going to prove or establish.
- Construction: In this part of the proposition, we note down all the additional lines or figures which must be drawn so that we may be able to arrive at the required result.
- Geometrical theorem: A theorem is that kind of proposition in which we establish a geometrical truth by means of reasoning with the help of a geometrical figure.
- Corollary: A corollary is also a proposition, the truth of which can be immediately drawn from the theorem that has already been proved.
- If a straight line stands on another straight line, the sum of measures of two angles so formed is equal to two right angles.
- Converse of theorem: When the 'Given' of one proposition becomes the 'To Prove' of the other proposition and vice versa, the two propositions are called converse of each other.
- If the sum of measure of two adjacent angles is equal to two right angles, the external arms of the angles are in a straight line.
- If two lines intersect each other, then the opposite vertical angles are congruent.
- If two sides of a triangle are congruent, then the angles opposite these sides are congruent.
- The sum of measures of the three angles of a triangle is 180° .

Unit - 11



Introduction to Trigonometry

After completion of this unit, the students will be able to:

- Define trigonometry.
- Define trigonometric ratios of an acute angle.
- Find trigonometric ratios of acute angles (30° , 60° and 45°).

11.1 TRIGONOMETRY

11.1.1 Introduction

The word **trigonometry** has been derived from a Greek word whose meaning is **measurement of triangles**. It is an important branch of mathematics which deals with the solution of triangles. Solution of a triangle means to find its three sides and angles. In the development of trigonometry, the Muslim mathematicians, particularly Abu-Abdullah Albatafi, Alberuni and Muhammad Bin Musa Alkharizimi made a lot of contributions. It plays an important role in business, engineering, surveying, navigation, astronomy, physical and social sciences.

11.1.2 Trigonometric Ratios of An Acute Angle

Let us consider a right angled triangle ABC with respect to an angle θ (theta) = $\angle CAB$ with $m\angle ABC = 90^\circ$. In a right angled triangle, the side in front of angle 90° is always called **hypotenuse**, the side in front of the given angle θ will be called **perpendicular** and the side between given angle and 90° will be the base of triangle.

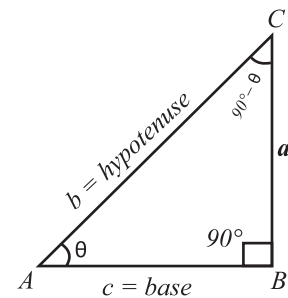

For the given right angled triangle ABC , the trigonometric ratios of the angle θ are defined as:

$$\frac{\text{perpendicular}}{\text{hypotenuse}} = \frac{a}{b} = \text{sine } \theta = \sin \theta$$

$$\frac{\text{base}}{\text{hypotenuse}} = \frac{c}{b} = \text{cosine } \theta = \cos \theta$$

$$\frac{\text{perpendicular}}{\text{base}} = \frac{a}{c} = \text{tangent } \theta = \tan \theta$$

The inverse of these ratios:

$$\frac{\text{hypotenuse}}{\text{perpendicular}} = \frac{b}{a} = \text{cosecant } \theta = \text{cosec } \theta$$

$$\frac{\text{hypotenuse}}{\text{base}} = \frac{b}{c} = \text{secant } \theta = \text{sec } \theta$$

$$\frac{\text{base}}{\text{perpendicular}} = \frac{c}{a} = \text{cotangent } \theta = \text{cot } \theta$$

Do you know?

$$(i) \quad \text{cosec } \theta = \frac{1}{\sin \theta}$$

$$(ii) \quad \text{sec } \theta = \frac{1}{\cos \theta}$$

$$(iii) \quad \text{cot } \theta = \frac{1}{\tan \theta}$$

Example 1:

In the given triangle ABC , $m\angle A = \theta$. Measurement of the sides a , b and c are given in the figure. Find the value of trigonometry ratios.

Solution:

$$\sin \theta = \frac{a}{b} = \frac{3}{5}, \quad \text{cosec } \theta = \frac{b}{a} = \frac{5}{3}$$

$$\cos \theta = \frac{c}{b} = \frac{4}{5}, \quad \text{sec } \theta = \frac{b}{c} = \frac{5}{4}$$

$$\tan \theta = \frac{a}{c} = \frac{3}{4}, \quad \text{cot } \theta = \frac{c}{a} = \frac{4}{3}$$

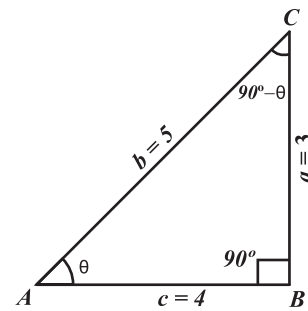

Example 2:

Using the values of trigonometric ratios of the above example, verify that:

i. $\sin \theta \times \text{cosec } \theta = 1$ ii. $\tan \theta \times \text{cot } \theta = 1$ iii. $\cos \theta \times \text{sec } \theta = 1$

Solution:

i. L.H.S = $\sin \theta \times \text{cosec } \theta = \frac{3}{5} \times \frac{5}{3} = 1 = \text{R.H.S}$

ii. L.H.S = $\tan \theta \times \text{cot } \theta = \frac{3}{4} \times \frac{4}{3} = 1 = \text{R.H.S}$

iii. L.H.S = $\cos \theta \times \text{sec } \theta = \frac{4}{5} \times \frac{5}{4} = 1 = \text{R.H.S}$

11.1.3 Trigonometric Ratios of Acute Angles 30° , 60° and 45°

• Trigonometric Ratios of 30°

Consider a right angled triangle ABC , in which $m\angle B = 90^\circ$ and $m\angle BAC = 30^\circ$. We know from elementary geometry that in a right angled triangle the side in front of angle 30° is always half in length to the hypotenuse.

Let $a = 1$ then $b = 2$

By Pythagoras theorem, we have

$$|\overline{AB}|^2 + |\overline{BC}|^2 = |\overline{AC}|^2$$

or $|\overline{AB}|^2 + (1)^2 = (2)^2$ (By putting the values)

$$\Rightarrow |\overline{AB}|^2 = 4 - 1 = 3$$

$$\Rightarrow |\overline{AB}| = \sqrt{3}$$

Trigonometric ratios of angle 30° will be:

$$\sin 30^\circ = \frac{m\overline{BC}}{m\overline{AC}} = \frac{1}{2} \quad \Rightarrow \quad \operatorname{cosec} 30^\circ = 2$$

$$\cos 30^\circ = \frac{m\overline{AB}}{m\overline{AC}} = \frac{\sqrt{3}}{2} \quad \Rightarrow \quad \sec 30^\circ = \frac{2}{\sqrt{3}}$$

$$\tan 30^\circ = \frac{m\overline{BC}}{m\overline{AB}} = \frac{1}{\sqrt{3}} \quad \Rightarrow \quad \cot 30^\circ = \sqrt{3}$$

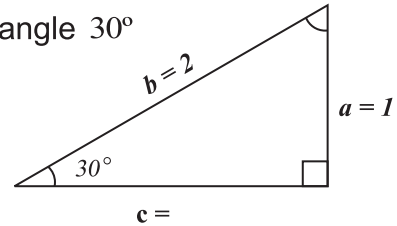

• Trigonometric Ratios of 60°

Consider a right angled triangle ABC , in which $m\angle B = 90^\circ$, $m\angle BAC = 60^\circ$, therefore $m\angle ACB = 30^\circ$

Then again by elementary geometry length of side AB is half in length to the hypotenuse.

Let $m\overline{AB} = 1$, then $m\overline{AC} = 2$.

By Pythagoras theorem, we have

$$|\overline{AB}|^2 + |\overline{BC}|^2 = |\overline{AC}|^2$$

or $(1)^2 + |\overline{BC}|^2 = (2)^2$ (By putting the values)

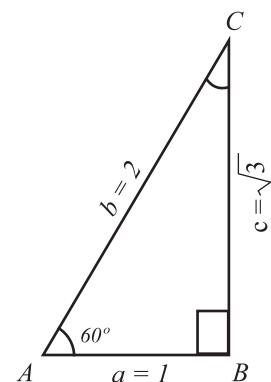

$$\Rightarrow |\overline{BC}|^2 = 4 - 1 = 3$$

$$\Rightarrow |\overline{BC}| =$$

$$\sin 60^\circ = \frac{m \overline{BC}}{m \overline{AC}} = \frac{\sqrt{3}}{2} \quad \Rightarrow \quad \operatorname{cosec} 60^\circ = \frac{2}{\sqrt{3}}$$

$$\cos 60^\circ = \frac{m \overline{AB}}{m \overline{AC}} = \quad \Rightarrow \quad \sec 60^\circ = 2$$

$$\tan 60^\circ = \frac{m \overline{BC}}{m \overline{AB}} = \sqrt{3} \quad \Rightarrow \quad \cot 60^\circ = \frac{1}{\sqrt{3}}$$

• **Trigonometric Ratios of 45°**

Consider a right angled triangle ABC in which $m\angle B = 90^\circ$

and $m\angle A = \theta = 45^\circ$. Since $m\angle A + m\angle B + m\angle C = 180^\circ$,

then $m\angle A = m\angle C = 45^\circ$

\therefore The triangle ABC is an isosceles triangle. Then

by elementary geometry $a = c = 1$

$$\Rightarrow b^2 = a^2 + c^2$$

$$= 1 + 1$$

$$b^2 = 2$$

$$\Rightarrow b = \sqrt{2}$$

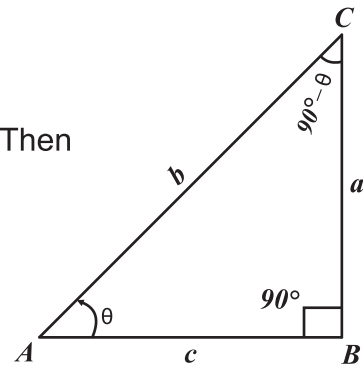

Therefore the values of trigonometric ratios of angle 45° will be:

$$\sin 45^\circ = \frac{m \overline{BC}}{m \overline{AC}} = \quad ; \quad \operatorname{cosec} 45^\circ = \frac{m \overline{AC}}{m \overline{BC}} =$$

$$\cos 45^\circ = \frac{m \overline{AB}}{m \overline{AC}} = \quad ; \quad \sec 45^\circ = \frac{m \overline{AC}}{m \overline{AB}} =$$

$$\tan 45^\circ = \frac{m \overline{BC}}{m \overline{AB}} = 1 \quad ; \quad \cot 45^\circ = \frac{m \overline{AB}}{m \overline{BC}} = 1$$

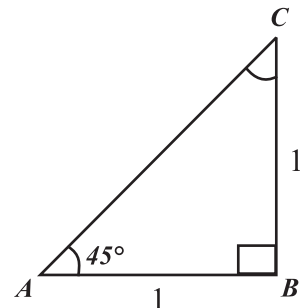

The trigonometric ratios of 30° , 45° , and 60° are given in the following table:

Ratio ↓ Angle →	30°	45°	60°
sin			
cos			
tan		1	

Example 3: Evaluate the following:

- i. $\sin 45^\circ \times \cos 30^\circ + \cos 45^\circ \times \sin 30^\circ$
- ii. $\sin 60^\circ \times \cos 30^\circ - \cos 60^\circ \times \sin 30^\circ$
- iii. $\sin 60^\circ \times \cos 45^\circ + \cos 60^\circ \times \sin 45^\circ$
- iv. $\cos 45^\circ \times \cos 30^\circ - \sin 45^\circ \times \sin 30^\circ$

Solution:

i. $\sin 45^\circ \times \cos 30^\circ + \cos 45^\circ \times \sin 30^\circ$

ii. $\sin 60^\circ \times \cos 30^\circ - \cos 60^\circ \times \sin 30^\circ$

iii. $\sin 60^\circ \times \cos 45^\circ + \cos 60^\circ \times \sin 45^\circ$

iv. $\cos 45^\circ \times \cos 30^\circ - \sin 45^\circ \times \sin 30^\circ$

EXERCISE 11.1

1. For each of the following right angled triangles, find the trigonometric ratios:

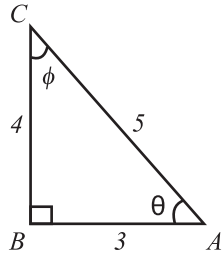

(a)

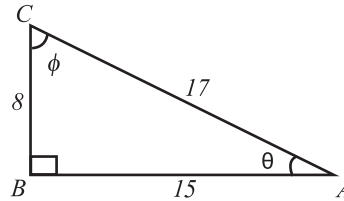

(b)

- (i) $\sin\theta$ (ii) $\cos\theta$ (iii) $\tan\theta$ (iv) $\sec\theta$ (v) $\operatorname{cosec}\theta$
 (vi) $\cot\phi$ (vii) $\tan\phi$ (viii) $\sin\phi$ (ix) $\sec\phi$ (x) $\cos\phi$

2. Find the trigonometric ratios of the triangle ABC given below.

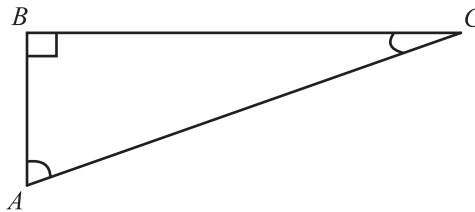

- (i) $\sin m\angle A$ (ii) $\cos m\angle A$ (iii) $\tan m\angle A$
 (iv) $\sin m\angle C$ (v) $\cos m\angle C$ (vi) $\tan m\angle C$

3. In a right angled triangle ABC , $m\angle B = 90^\circ$ and $m\angle C = 60^\circ$ also, $\sin m\angle C = \frac{c}{b}$. Find the following trigonometric ratios:

- (i) $\overline{mBC} / \overline{mAB}$ (ii) $\cos 60^\circ$ (iii) $\tan 60^\circ$ (iv) $\sec 60^\circ$
 (v) $\operatorname{cosec} 60^\circ$ (vi) $\cot 60^\circ$ (vii) $\sin 30^\circ$ (viii) $\cos 30^\circ$
 (ix) $\tan 30^\circ$ (x) $\sec 30^\circ$ (xi) $\operatorname{cosec} 30^\circ$ (xii) $\cot 30^\circ$

4. Find the values of the following:

- (i) $2\sin 60^\circ \cos 60^\circ$ (ii) $2\sin 45^\circ + 2\cos 45^\circ$
 (iii) $\cos 60^\circ \cos 30^\circ - \sin 60^\circ \sin 30^\circ$ (iv) $\cos 60^\circ \cos 30^\circ + \sin 60^\circ \sin 30^\circ$

REVIEW EXERCISE 11

1. Four options are given below for each statement. Encircle the correct one.

- i. $\sin (90^\circ - 60^\circ) = \cos$ _____.
(a) 90° (b) 60° (c) 30° (d) 0°
- ii. $\tan 60^\circ = \tan (90^\circ - 30^\circ) = \cot$ _____.
(a) 90° (b) 30° (c) 60° (d) 0°
- iii. The inverse of $\sin \theta$ is _____.
(a) $\operatorname{cosec} \theta$ (b) $\sec \theta$ (c) $\cot \theta$ (d) $\tan \theta$
- iv. The inverse of $\cos \theta$ is _____.
(a) $\operatorname{cosec} \theta$ (b) $\sec \theta$ (c) $\cot \theta$ (d) $\tan \theta$
- v. The inverse of $\tan \theta$ is _____.
(a) $\operatorname{cosec} \theta$ (b) $\sec \theta$ (c) $\cot \theta$ (d) $\tan \theta$
- vi. The value of $\sin 30^\circ$ is _____.
(a) 1 (b) $\frac{1}{2}$ (c) (d) 0
- vii. The value of $\cos 60^\circ$ is _____.
(a) 1 (b) $\frac{1}{2}$ (c) (d) 0
- viii. The value of $\sin 60^\circ$ is _____.
(a) 1 (b) $\frac{1}{2}$ (c) (d) 0
- ix. The value of $\sin 90^\circ$ is _____.
(a) 1 (b) $\frac{1}{2}$ (c) (d) 0
- x. The value of $\tan 45^\circ$ is _____.
(a) 1 (b) $\frac{1}{2}$ (c) (d) 0
- xi. The value of $\cos 45^\circ$ is _____.
(a) 1 (b) (c) (d) 0

2. Find the values:
- (i) $2 \sin 45^\circ + \cos 45^\circ$ (ii) $2 \cos 30^\circ \sin 30^\circ$
(iii) $2 \sin 45^\circ + 2 \cos 45^\circ$ (iv) $\tan 45^\circ \cot 45^\circ$
3. If $\sin 45^\circ$ and $\cos 45^\circ$ is equal to each, then find the values of the following:
- (i) $\sin 45^\circ + \cos 45^\circ$ (ii) $3 \cos 45^\circ + 4 \sin 45^\circ$
(iii) $5 \cos 45^\circ - 3 \sin 45^\circ$

SUMMARY

- Trigonometry is derived from three words: Trei (three), Goni (angles) and Metron (measurement).
- Trigonometry defines the relations between elements of a triangle and it includes the methods for computing different elements of a triangle.
- The three most common ratios in trigonometry are sine, cosine and tangent. Trigonometric ratios are simply one side of a triangle divided by another.
- The trigonometric ratios are used to relate the angles to the lengths of the sides of a right angled triangle.
- $\sin \theta = \frac{\text{perpendicular}}{\text{hypotenuse}}$
- $\cos \theta = \frac{\text{base}}{\text{hypotenuse}}$
- $\tan \theta = \frac{\text{perpendicular}}{\text{base}}$



After completion of this unit, the students will be able to:

- Define frequency, frequency distribution.
- Construct frequency table.
- Construct a histogram representing frequency table.
- Describe measures of central tendency.
- Calculate mean (average), weighted mean, median and mode for ungrouped data.
- Solve real life problems involving mean (average), weighted mean, median and mode.

12.1 FREQUENCY AND FREQUENCY DISTRIBUTION.

12.1.1 Definitions

- **Frequency**

The number of times a value occurs in a data is called the frequency of that value.

For example: The marks obtained out of 10 in a test by 15 students of a class are as follows:

3, 5, 7, 10, 7, 9, 3, 7, 5, 4, 6, 8, 7, 5, 2.

- The data consists of 15 values.
- Some of the values are occurring more than once e.g., 3, 5, 7.
- The frequency of 3 marks is 2.
- The frequency of 5 marks is 3.
- The frequency of 7 marks is 4.
- All other values have frequency 1.

- **Frequency Distribution**

To write a data in the form of a table in such a way that the frequency of each class can be observed at once is called its **frequency distribution**.

10.1.2 Construction of Frequency Distribution Table

Let us consider the given weights in *kg* of 50 students selected from a school:

*35, 30, 32, 36, 31, 40, 35, 42, 35, 45, 37, 41, 33, 37, 30, 28, 29,
30, 32, 33, 31, 35, 36, 30, 28, 37, 39, 28, 31, 34, 39, 45, 38, 36,
35, 28, 31, 34, 30, 41, 35, 36, 41, 28, 31, 34, 30, 29, 28, 37*

We note that the weights of the selected students range from 28 *kg* to 45 *kg*. We arrange the data in groups in the form of a table as below:

Class Interval	Frequency
<i>28 – 30</i>	<i>14</i>
<i>31 – 33</i>	<i>9</i>
<i>34 – 36</i>	<i>13</i>
<i>37 – 39</i>	<i>7</i>
<i>40 – 42</i>	<i>5</i>
<i>43 – 45</i>	<i>2</i>
<i>Total:</i>	<i>50</i>

In the above table the frequency of the group of students whose weights from 28 *kg* to 30 *kg* are 14 and similarly the other class frequencies can easily be seen.

- (i) Look for the largest value and the smallest value i.e., 45 and 28 respectively.
- (ii) Number of classes to be made is 6.
- (iii) For finding the size of class interval use the formula.

$$\text{Size of class interval} = \frac{\text{largest value} - \text{smallest value}}{\text{number of classes}}$$

$$= \frac{45 - 28}{6} = \frac{17}{6}$$

$$\approx 2.8 \approx 3$$

Example 1:

Listed below are the scores of 50 students in a 60 marks test.

25, 33, 26, 34, 28, 35, 29, 36, 30, 54, 30, 39, 36, 37, 39, 40, 37, 34,
27, 41, 37, 41, 38, 42, 48, 51, 40, 51, 43, 40, 41, 39, 48, 51, 53, 41,
37, 52, 28, 46, 44, 37, 39, 52, 51, 40, 45, 46, 43, 53

Make a frequency distribution table taking 6 classes of equal size by tally marks.

Solution:

$$\text{Lowest value} = 25$$

$$\text{Highest value} = 54$$

$$\text{Total classes to be made} = 6$$

$$\text{We take the size of class} = \frac{54 - 25}{6}$$

$$= \frac{29}{6} = 5 \text{ (approx.)}$$

Class Interval	Tally Mark	Frequency
25 - 29		6
30 - 34		5
35 - 39		13
40 - 44		12
45 - 49		5
50 - 54		9
Total:		50

Example 2: The number of units of electricity consumed by 31 households are listed below. Construct a frequency table with 10 classes.

727, 773, 859, 711, 860, 747, 862, 738, 774, 852, 791, 836, 834,
752, 828, 792, 908, 839, 752, 715, 880, 838, 852, 816, 751, 834,
818, 835, 831, 778, 837

Solution: Lowest value = 711

Highest value = 908

Total classes to be made = 10

$$\begin{aligned} \text{Size of class interval} &= \frac{908 - 711}{10} \\ &= \frac{197}{10} = 19.7 \simeq 20 \end{aligned}$$

Class Interval	Tally Mark	Frequency
711 – 730		3
731 – 750		2
751 – 770		3
771 – 790		3
791 – 810		2
811 – 830		3
831 – 850		8
851 – 870		5
871 – 890		1
891 – 910		1
Total:		31

12.1.3 Construction of Histogram

We are familiar with pie and bar graphs. Another common graphic way of presenting data is by means of a histogram. A histogram is similar to bar graph but it is constructed for a frequency table.

In a histogram the values of the data (classes) are represented along the horizontal axis and the frequencies are shown by bars perpendicular to the horizontal axis. Bars of equal width are used to represent individual classes of frequency table.

To draw a histogram from a grouped data, the following steps are followed.

- (i) Draw X -axis and Y -axis.
- (ii) Mark class boundaries of the classes along X -axis.
- (iii) Mark frequencies along Y -axis.
- (iv) Draw a bar for each class so that the height of the bar drawn for each class is equal to the frequency of the class.

The graph is shown below:

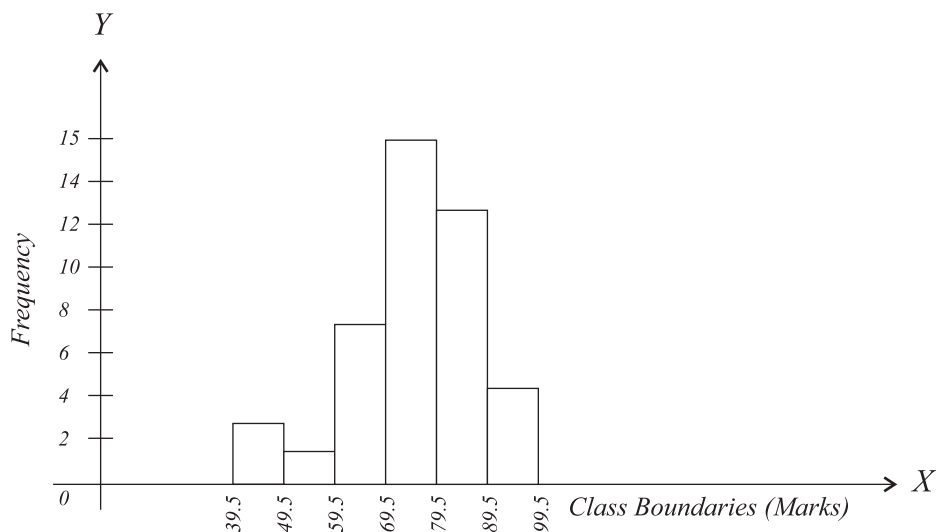

Example 3: The detail of distances travelled daily by the residents of a locality are given below. Construct a histogram for the following frequency table.

Distance travelled (in km)	1 - 8	9 - 16	17 - 24	25 - 32	33 - 40
Number of persons	15	12	7	4	2

Solution: Frequency distribution table is:

Distance travelled (km)	Class boundries	Frequency (No. of Persons)
$1 - 8$	$0.5 - 8.5$	15
$9 - 16$	$8.5 - 16.5$	12
$17 - 24$	$16.5 - 24.5$	7
$25 - 32$	$24.5 - 32.5$	4
$33 - 40$	$32.5 - 40.5$	2
Total:		40

Histogram:

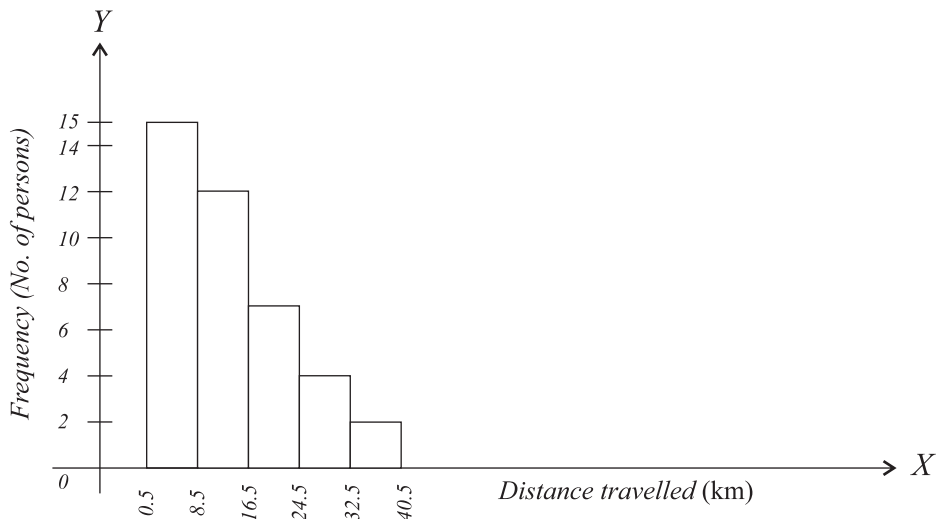

EXERCISE 12.1

1. The following data displays the number of draws of different categories of bonds.

35, 55, 64, 70, 99, 89, 87, 65, 67, 38, 62, 60, 70, 78, 69, 86, 39, 71, 56, 75,

51, 99, 68, 95, 86, 53, 59, 50, 47, 55, 81, 80, 98, 51, 63, 66, 79, 85, 83, 70

Construct a frequency distribution table for the above data, with seven classes of equal size and of class interval 10.

2. Listed below are the number of electricity units consumed by 50 households in a low income group locality of Lahore.

55, 45, 64, 130, 66, 155, 80, 102, 62, 60, 101, 58, 75, 81, 111, 90, 55, 151,
66, 139, 77, 99, 67, 51, 50, 125, 83, 55, 136, 91, 86, 54, 78, 100, 113, 93,
104, 111, 113, 96, 96, 87, 109, 94, 129, 99, 69, 83, 97, 97

With 12 classes of equal width of 10, construct a frequency table for the electricity units consumed.

3. The following list is of scores in a mathematics examination. Using the starting class $40 - 44$, set up a frequency distribution. List the class boundaries and class marks.

63, 88, 79, 92, 86, 87, 83, 78, 40, 67, 68, 76, 46, 81, 92, 77, 84, 76, 70, 66,
77, 75, 98, 81, 82, 81, 87, 78, 70, 60, 94, 79, 52, 82, 77, 81, 77, 70, 74, 61

4. Construct a frequency distribution for the following numbers using $1 - 10$ as the starting class. List the class boundaries.

54, 67, 63, 64, 57, 56, 55, 53, 53, 54, 44, 45, 45, 46, 47, 37, 23, 34, 44, 27,
36, 45, 34, 36, 15, 23, 43, 16, 44, 34, 36, 35, 37, 24, 24, 14, 43, 37, 27, 36,
33, 25, 36, 26, 5, 44, 13, 33, 33, 17

5. Following are the number of days that 36 tourists stayed in some city.

1, 6, 16, 21, 41, 21, 5, 31, 20, 27, 17, 10, 3, 32, 2, 48, 8, 12, 21, 44, 1, 36, 5,
12, 3, 13, 15, 10, 18, 3, 1, 11, 14, 12, 64, 10.

Construct a frequency distribution starting with the class $1 - 7$.

6. Construct a histogram for each of the frequency tables in questions 1 – 5.

12.2 MEASURES OF CENTRAL TENDENCY

In the previous section we have learnt to arrange data into distribution table to understand the given data easily. sometimes, the volume of data is large and it is very difficult to compare, understand and analyze. Then there is need to make that data comparable to avoid difficulty and complexity.

12.2.1 Description of Measures of Central Tendency

The **Measures of Central Tendency** are the Concept of Averages, Mean, Mode and Median.

12.2.2 Calculation of Measures of Central Tendency

- **Mean (Average)**

Let x_1, x_2, \dots, x_n be n given quantities. Then their average is the value presenting the tendency of these quantities and is called their Mean value or Mean. It can be calculated by the formula:

$$\bar{X} = \frac{x_1 + x_2 + \dots + x_n}{n}$$

$$\bar{X} = \frac{\text{sum of all values}}{\text{number of values}}$$

Example 4:

The scores of a student in eight papers are 58, 72, 65, 85, 94, 78, 87, 85. Find the mean score.

$$\bar{X} = \frac{58 + 72 + 65 + 85 + 94 + 78 + 87 + 85}{8}$$

$$\bar{X} = \frac{624}{8} = 78$$

Hence, mean score is 78

- **Weighted Mean**

When all values of given data have same importance, then we use mean. But when different values have different importance then these values are known as weights.

If $x_1, x_2, x_3, \dots, x_n$ have the weights $w_1, w_2, w_3, \dots, w_n$ then:

$$\text{Weighted Mean} = \bar{X}_w = \frac{w_1x_1 + w_2x_2 + w_3x_3 + \dots + w_nx_n}{w_1 + w_2 + w_3 + \dots + w_n} = \frac{\sum wx}{\sum w}$$

Example 5:

The following data describes the marks of a student in different subjects and weights assigned to these subjects are also given:

Marks (x)	74	78	74	90
Weights (w)	4	3	5	6

Find its weighted mean:

Solution:

$$\begin{aligned}
 \text{Weighted Mean} = \bar{X}_w &= \frac{4(74) + 3(78) + 5(74) + 6(90)}{4 + 3 + 5 + 6} \\
 &= \frac{296 + 234 + 370 + 540}{18} \\
 &= \frac{1440}{18} = 80 \text{ marks}
 \end{aligned}$$

- **Median**

If a data is arranged in ascending or descending order then median of the data is:

- (a) The middle value of the data, if it consists of odd number of values.
- (b) The mean of the two middle values of the data is the Median of the data if the number of values in a data is even.

Example 6: The weights in kg of 9 students are as under, find the median:

29, 32, 45, 27, 30, 47, 35, 37, 33

Solution:

Arranging these values in descending order:

47, 45, 37, 35, 33, 32, 30, 29, 27

The middle value is 33

So, Median = 33 Kg

- **Mode**

Mode is the value that occurs most frequently in a data . In case no value is repeated in a data, then the data has no mode. If two or more values occur with the same greatest frequency, then each is a mode.

Example 7: Find the mode of the given data:

1, 2, 5, 7, 8, 2, 2, 4, 3, 5, 7

Solution: The value 2 is repeated the most, so 2 is the mode of this data.

Example 8: Find the mode of the given data:

2, 4, 6, 8, 10, 12, 14, 16, 20

Solution: This data has no mode because no value is repeated in the given data

Example 9: Find the mode of the data given below:

1, 2, 2, 2, 3, 4, 5, 5, 5, 6, 7

Solution: Since 2 is repeated 3 times and 5 is also repeated 3 times so this data has two modes i.e., 2 and 5.

Remember that:

- | |
|---|
| <ul style="list-style-type: none">(i) A data can have more than one Mode.(ii) A data may or may not have a Mode. |
|---|

12.2.3 Real life problems involving Mean, Weighted Mean, Median and Mode

Example 10:

The heights of 12 students (in centimeters) of 8th class are given below:

148, 144, 145, 146, 148, 150, 145, 155, 151, 152, 145, 149

- (i) Find the average height of a student.
- (ii) Find the most common height.
- (iii) Find the Median height.

Solution:

Arrange the given data in ascending order:

144, 145, 145, 145, 146, 148, 148, 149, 150, 151, 152, 155

$$\begin{aligned} \text{(i) Mean (average)} &= \frac{144 + 145 + 145 + 145 + 146 + 148 + 148 + 149 + 150 + 151 + 152 + 155}{12} \\ &= \frac{1778}{12} = 148.16 \end{aligned}$$

Therefore, average height of a student is *148.16cm*

(ii) The most occurred value is *145* (3 times)

(iii) The total number of values is *12*. So, 6^{th} and 7^{th} terms are the middle values of data.

$$\begin{aligned} \therefore \text{Median} &= \left(\frac{6^{\text{th}} \text{ term} + 7^{\text{th}} \text{ term}}{2} \right) \\ &= \frac{148 + 148}{2} = \frac{296}{2} = 148 \end{aligned}$$

Therefore, the median is *148cm*

EXERCISE 12.2

1. Compute the mean, median and mode of the following data:

(i) *10, 8, 6, 0, 8, 3, 2, 5, 8, 4*

(ii) *1, 3, 5, 3, 5, 3, 7, 5, 7, 5, 7*

(iii) *5, 4, 1, 4, 0, 3, 4, 119*

(iv) *62, 90, 71, 83, 75*

(v) *45, 65, 80, 92, 80, 75, 56, 96, 62, 78*

(vi) Number of letters in first 20 words in a book.

3, 2, 5, 3, 3, 2, 3, 3, 2, 4, 2, 2, 3, 2, 3, 5, 3, 4, 4, 5

(vii) The number of calories in nine different beverages of 250mm bottles:

99, 106, 101, 103, 108, 107, 107, 106, 108

- (viii) Number of rooms in 15 houses of a locality city
5, 9, 8, 6, 8, 7, 6, 7, 9, 8, 7, 9, 7, 8, 5
- (ix) Number of books in 10 school libraries, (in hundreds)
78, 215, 35, 267, 39, 17, 418, 286, 335, 50.
- (x) Cost per day on a patient in 10 private hospitals (in rupees)
4125, 2500, 3115, 6580, 7150, 3750, 5920, 4575, 3225, 2500

2. A person purchased the following food items:

Food items	Quantity (in kg)	Cost per kg (in Rs.)
Rice	10	96
Flour	12	48
Ghee	4	190
Sugar	3	49
Mutton	2	650

What is the average cost of food items per kg?

3. The following distances (in km) were travelled by 40 students to reach their school.

2, 8, 1, 5, 9, 5, 14, 10, 31, 20, 15, 4, 10, 6, 5, 10, 5, 18, 12, 25, 30, 27, 20, 3, 9, 15, 15, 18, 10, 1, 1, 6, 25, 16, 7, 12, 1, 8, 21, 12.

Compute the mean, median and mode of the distances travelled.

4. Following table lists the size of 127 families:

Size of Family	2	3	4	5	6	7	8
Frequency	51	31	27	12	4	1	1

Compute the mean, median and mode.

5. Find the class mark and mean of the following frequency table:

Class Interval	0 - 39	40 - 79	80 - 119	120 - 159	160 - 199
Frequency	17	41	80	99	4

6. Find the mean of the following frequency table:

Class interval	1 - 5	6 - 10	11 - 15	16 - 20	21 - 25	26 - 30	31 - 35	36 - 40
Frequency	19	24	18	21	23	20	16	15

7. The diagram illustrates the number of children per family of a sample of 100 families in a certain housing estate:

- (a) State the modal number of children per family.
- (b) Calculate the mean number of children per family.
- (c) Find the median number of children per family.

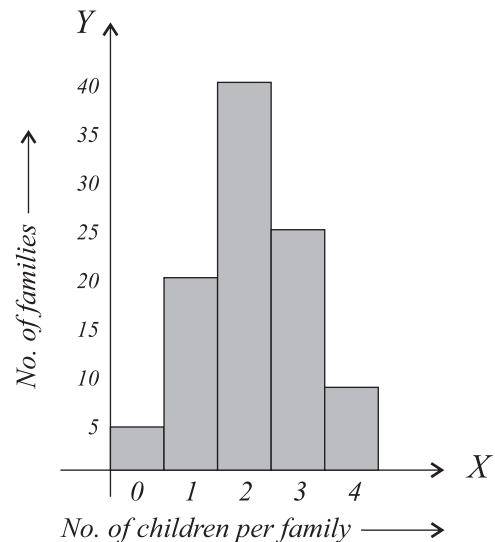

REVIEW EXERCISE 12

1. Four options are given against each statement. Encircle the correct one.
- i. What is the missing number of data 14, 24, _____, 18, 30, when mean is 23.
(a) 28 **(b)** 29 **(c)** 30 **(d)** 31
- ii. What is the missing number of data 40, 28, 16, 18, 37, 20, _____, 35, when median is 26.
(a) 20 **(b)** 22 **(c)** 24 **(d)** 28
- iii. A number which indicates how often a value occurs is called:
(a) Frequency **(b)** Mode **(c)** Median **(d)** Average
- iv. An arrangement of the values that one or more variables taken in data is called:
(a) Frequency **(b)** Frequency distribution
(c) Median **(d)** Mode
- v. A representation of a frequency distribution by means of rectangles whose widths represent class intervals and whose areas are proportional to the corresponding frequencies is called:
(a) Histogram **(b)** Bar chart **(c)** Pie chart **(d)** Line graph

- vi. A measure of central tendency that attempts to describe a data by identifying the central position within that data:
- (a) is a single value (b) are multiple values
(c) are duplicate values (d) are repeating values
- vii. The statistical measure that identifies a single value as representative of an entire distribution is called:
- (a) frequency distribution (b) histogram
(c) mean (d) central tendency
- viii. The value which occupies the middle position when all the observations are arranged in an ascending/descending order is called:
- (a) Frequency distribution (b) Median
(c) Mode (d) Mean
- ix. The value that occurs most frequently in the data is called:
- (a) Frequency distribution (b) Median
(c) Mode (d) Mean
2. Calculate the mean, median and mode for each set of data given below:
- (a) 3, 6, 3, 7, 4, 3, 9 (b) 11, 10, 12, 12, 9, 10, 14, 12, 9
(c) 2, 9, 7, 3, 5, 5, 6, 5, 4, 9 (d) 6, 8, 11, 5, 2, 9, 7, 8
(e) 153.8, 154.7, 156.9, 154.3, 152.3, 156.1, 152.3
3. Test scores of a class of 20 students are as follows:
93, 84, 97, 98, 100, 78, 86, 100, 85, 92, 72, 55, 91, 90, 75, 94, 83, 60, 81, 95
Draw a frequency distribution table and histogram for grouped data.
4. The price of 10 litre of drinking water was recorded at several stores, and the results are displayed in the table below:

Price (Rs.)	Frequency
74	1
75	2
76	8
77	10
78	2
79	1
80	1

Find the mean, median and mode of the price.

SUMMARY

- Frequency is a number which indicates how often value occurs.
- A frequency distribution is a summary of how often different scores occur within a sample of scores.
- A frequency distribution table is one way we can organize data so that it makes more sense. We could draw a frequency distribution table, which will give a better picture of our data than a simple list.
- A histogram is a representation of a frequency distribution by means of rectangles whose widths represent class intervals and whose areas are proportional to the corresponding frequencies.
- A measure of central tendency is a single value that attempts to describe data by identifying the central position within that data.
- Central tendency is defined as "the statistical measure that identifies a single value as representative of an entire distribution".
- Arithmetic mean (or, simply, "mean or average") is the most popular and well known measure of central tendency.
- The mean is equal to the sum of all the values in the data divided by the number of values in the data:

$$\text{Mean} = \frac{\text{sum of data}}{\text{number of observations}} \text{ or } \bar{x} = \frac{x_1 + x_2 + x_3 + \dots + x_n}{n}$$

- Median is the value which occupies the middle position when all the observations are arranged in an ascending / descending order.
 - (a) The middle value of the data, if it consists of odd number of values.
 - (b) The mean of the two middle values of the data is the Median of the data if the number of values in a data is even.
- Mode is defined as the value that occurs most frequently in the data. Some data do not have a mode because each value occurs only once.

Answers

EXERCISE 1.1

1. (i) $\{\phi\}$ (ii) $\phi, \{1\}$ (iii) $\phi, \{a\}, \{b\}, \{a, b\}$
 2. (i) ϕ (ii) $\phi, \{0\}, \{1\}$ (iii) $\phi, \{1\}, \{2\}, \{3\}, \{1, 2\}, \{1, 3\}, \{2, 3\}$
 3. (i) $\{\phi, \{-1\}, \{1\}, \{-1, 1\}\}$ (ii) $\{\phi, \{a\}, \{b\}, \{c\}, \{a, b\}, \{a, c\}, \{b, c\}, \{a, b, c\}\}$

REVIEW EXERCISE 1

1. (i) c (ii) d (iii) b (iv) c (v) c
 (vi) c (vii) b (viii) d (ix) c
3. (i) All subsets of $A = \phi, \{e\}, \{f\}, \{g\}, \{e, f\}, \{e, g\}, \{f, g\}, \{e, f, g\}$
 All subsets of $B = \phi, \{1\}, \{3\}, \{5\}, \{1, 3\}, \{1, 5\}, \{3, 5\}, \{1, 3, 5\}$
 (ii) $\{\{\}, \{a\}, \{b\}, \{c\}, \{a, b\}, \{a, c\}, \{b, c\}, \{a, b, c\}\}$

EXERCISE 2.1

1. (i) 0.714... , Non-Terminating (ii) 0.6 , Terminating
 (iii) 0.857... , Non-Terminating (iv) 0.2857... , Non-Terminating
 (v) 0.375 , Terminating (vi) 1.6 , Terminating
2. (i) 0.428571, Repeating (ii) 0.8 , None
 (iii) 0.75 , None (iv) 0.916, Repeating
 (v) 0.142857 , Repeating (vi) 0.8, Repeating
 (vii) 3.125 , None (viii) 3.142857 , Repeating
 (ix) 3.25 , None (x) 3.5 , None
 (xi) 14.5 , None (xii) 3.3, Repeating

EXERCISE 2.2

1. (i) 49 (ii) 121 (iii) 361 (iv) 625 (v) 1369 (vi) 5625
2. (i) $1 + 2 + 3 + 4 + 5 + 6 + 5 + 4 + 3 + 2 + 1$
 (ii) $1 + 2 + 3 + 4 + 5 + 6 + 7 + 6 + 5 + 4 + 3 + 2 + 1$
 (iii) $1 + 2 + 3 + 4 + 3 + 2 + 1$
 (iv) $1 + 2 + 3 + 4 + 5 + 4 + 3 + 2 + 1$
 (v) $1 + 2 + 3 + 2 + 1$
 (vi) $1 + 2 + 3 + 4 + 5 + 6 + 7 + 8 + 7 + 6 + 5 + 4 + 3 + 2 + 1$

EXERCISE 2.3

1. (i) 28 (ii) 35 (iii) 53 (iv) 65 (v) 72
 (vi) 88 (vii) 36 (viii) 42 (ix) 171
2. (i) 117 (ii) 171 (iii) 321 (iv) 647 (v) 223
 (vi) 236 (vii) 490 (viii) 3214

EXERCISE 2.4

1. (i) $\frac{7}{8}$ (ii) $\frac{11}{25}$ (iii) $\frac{14}{21}$ (iv) $1\frac{1}{6}$ (v) $\frac{26}{27}$ (vi) $3\frac{3}{5}$
 2. (i) $\frac{4}{5}$ (ii) $\frac{13}{16}$ (iii) $\frac{28}{29}$ (iv) $\frac{32}{35}$ (v) $2\frac{3}{8}$

EXERCISE 2.5

1. (i) 1.1 (ii) 0.8 (iii) 2.7 (iv) 1.2 (v) 1.3 (vi) 3.5
 2. (i) 0.57 (ii) 0.72 (iii) 3.2 (iv) 4.53 (v) 25.47
 (vi) 54.6 (vii) 87.256 (viii) 0.0932 (ix) 48.73

EXERCISE 2.6

1. (i) 1.414 (ii) 1.732 (iii) 2.236 (iv) 2.646 (v) 3.317 (vi) 3.873
 2. (i) 1.90 (ii) 2.53 (iii) 5.38 (iv) 7.96 (v) 28.57 (vi) 6.00

EXERCISE 2.7

1. (i) 3 (ii) 3 (iii) 3 (iv) 3 (v) 3 (vi) 4 (vii) 4
 (viii) 4 (ix) 4 (x) 3 (xi) 4 (xii) 4

EXERCISE 2.8

1. 120m 2. 2600m 3. 350 trees 4. 464m 5. 14dm 6. 120m, 240m
 7. 187 8. 28m 9. 350m 10. 1000m, Rs.50,000

EXERCISE 2.9

1. (i), (iii), (iv), (v)
 2. (i) 9 (ii) 25 (iii) 24 3. (i) 2.744 (ii) 0.064 (iii) 0.512
 4. (i) $\frac{1}{2}$ (ii) 33 (iii) 15

REVIEW EXERCISE 2

1. (i) c (ii) d (iii) c (iv) a (v) c (vi) a
 (vii) c (viii) c (ix) a (x) d (xi) a (xii) d
 2. (a) 3,647 (b) 4,5509 (c) 3,112
 3. (a) $\frac{16}{3}$ (b) $\frac{71}{17}$ (c) $\frac{131}{13}$ (d) 0.231 (e) 0.452
 (f) 12.36 (g) 0.506 (h) 6.165 (i) 8.019
 4. 402m 5. 14 marbles 6. (a) 12 (b) 15 (c) $\frac{6}{5}$

EXERCISE 3.1

1. (i) 5 (ii) 274 (iii) 110 (iv) 3598 (v) 1264 (vi) 724
 (vii) 73 (viii) 400

2. (i) $(10111101001)_2, (5721)_8, (44100)_5$ (ii) $(110111001)_2, (3231)_5$
 (iii) $(10000000110)_2, (13110)_5$ (iv) $(1101100011)_2, (11432)_5, (1543)_8$
 (v) $(1103)_5, (231)_8$

EXERCISE 3.2

1. (i) $(1100)_2$ (ii) $(100011111110)_2$ (iii) $(1011)_2$
 (iv) $(101000)_2$ (v) $(110101100101)_2$ (vi) $(12232)_5$
 (vii) $(1120231)_5$ (viii) $(11124)_5$ (ix) $(2234230444)_5$
 (x) $(232041310)_5$ (xi) $(10307)_8$ (xii) $(1644)_8$
 (xiii) $(3066226)_8$ (xiv) $(1444371)_8$ (xv) 564
2. (i) $(101000010)_2, (2242)_5, (502)_8$ (ii) $(1001100000)_2, (4413)_5, (1140)_8$
 (iii) $(1101010)_2, (411)_5, (152)_8$ (iv) $(10010110001)_2, (14301)_5, (2261)_8$
 (v) $(1000111110011)_2, (120332)_5, (10563)_8$
 (vi) $(110001111101011)_2, (402104)_5, (30753)_8$
 (vii) $(111000011010000001010)_2, (433121310)_5, (7032012)_8$
 (viii) $(110101100001101000)_2, (24003430)_5, (654150)_8$
 (ix) $(1100000111000110100)_2, (11002431)_5, (1627064)_8$
 (x) $(10011001101111010011100)_2, (2242201344)_5, (23157234)_8$

REVIEW EXERCISE 3

1. (i) d (ii) d (iii) b (iv) b (v) b (vi) a (vii) a
 3. (i) 5 (ii) 8 (iii) 253 (iv) 1726 (v) 169
 4. (i) $(1104)_5, (232)_8$ (ii) $(11240)_5, (1464)_8$ (iii) $(41030)_5, (5120)_8$
 (iv) $(3122410)_5, (144625)_8$ (v) $(12043)_5, (1602)_8$
 5. (i) $(11110)_2$ (ii) $(111110)_2$ (iii) $(1001)_2$
 6. (i) $(23312)_5$ (ii) $(3144)_5$ (iii) $(12040)_5$ (iv) $(13313)_5$
 7. (i) $(1075)_8$ (ii) $(2322)_8$ (iii) $(23114162)_8$ (iv) $(253715)_8$
 8. (i) 1160 (ii) 163 (iii) 21881

EXERCISE 4.1

1. 32 days 2. 36kg 3. Rs.18,864 4. Rs.60,000 5. 112 men
 6. Rs.10 7. 240 masons 8. 480 sweaters 9. 672 men
 10. 400 cycles.

EXERCISE 4.2

1. Aslam's profit: Rs.31,500. Akram's profit: Rs.35,000
 2. Amina's profit: Rs.3,600 Maryam's profit: Rs.4,800
 3. 1st partner's share: Rs.7,320 4. Saad's loss: Rs.3,000
 2nd partner's share: Rs.4,270 Saud's loss: Rs.4,500
 Saeed's loss: Rs.6,000

5. Akram's profit: Rs.6,000
Asghar's profit: Rs.8,000
7. Aslam's profit: Rs.1,400
Akram's profit: Rs.120
Asghar's profit: Rs.100
6. A's profit: Rs.3,000
B's profit: Rs.3,600
C's profit: Rs.5,400

EXERCISE 4.3

- Son's share Rs.48,000, Daughter's share Rs.24,000
- Widow Rs.1,00,000, Son Rs.2,80,000, Daughter Rs.1,40,000
- Widow Rs.87,500, Son Rs.1,22,500, Daughter Rs.61,250
- Widow Rs.9,000, Son Rs.42,000, Daughter Rs.21,000
- Son Rs.2,00,000, Daughter Rs.1,00,000,
- Widow Rs.75,000, Son Rs.3,50,000, Daughter Rs.1,75,000
- Son Rs.40,000, Daughter Rs.20,000,
- Husband Rs.45,000, Son Rs.67,500, Daughter Rs.33,750

EXERCISE 4.4

- \$701.40
- £445.10
- 1862.20 SAR
- 30,000 Indian Rupees
- 377.28 Australian Dollars
- 5028.28 Chinese Yuan
- 543.48 Canadian Dollars
- 1505.38 Turkish Lira

EXERCISE 4.5

- Rs.4,800
- Rs.4,500
- Rs.14,000
- Rs.75,000
- 3%
- $7\frac{1}{2}\%$
- 3 years
- 2 years
- Rs.14,550
- (i) Rs.2,193.75 (ii) Rs.57,150
- Rs.22,92,960

EXERCISE 4.6

- 10%
- Rs.2,400
- Rs.3,900
- Rs.1,584
- Discount Rs.1,600; Sale price Rs.6,400
- Discount of food items = Rs.187.50; Sale price = Rs.1062.50
Discount of other items = Rs.150; Sale price = Rs.600
- Rs.575

EXERCISE 4.7

- Rs.56,250
- Rs.10,900 included premium fee
- Rs.14,170
- Rs.2992.50
- Rs.78039.36
- Rs.1,19,700
- Rs.69,105

EXERCISE 4.8

- Rs.1,000
- Rs.51,000
- Rs.91,875
- Rs.117,500
- Rs.236,250
- Rs.337,500
- Rs.446,875
- Rs.596,875
- Rs.3,145,500, Rs.2,945,500

REVIEW EXERCISE 4

1. (i) a (ii) a (iii) a (iv) b (v) b (vi) a (vii) a
 (viii) a (ix) b (x) c
 4. Rs. 19,200 5. Rs. 1,515,000 6. Rs. 50,000 7. 28%

EXERCISE 5.1

1. (i) 4 (ii) -1 (iii) 0 (iv) -8
 2. (i) x (ii) y, x (iii) x (iv) y
 3. (i) a, b and c (ii) c and d (iii) b and d (iv) a and d
 4. Expressions in (i), (ii), (v) and (vi) are polynomials and expressions in (iii) and (iv) are not polynomials.
 5. (i) 7, -6 and 3 (ii) 5 and -3 (iii) 8, 2 and 5 (iv) 9, 3 and -2
 6. (i) 1 (ii) 2 (iii) 3 (iv) 4
 7. (i) linear (ii) quadratic (iii) quadratic (iv) linear (v) cubic
 (vi) biquadratic (vii) biquadratic (viii) quadratic

EXERCISE 5.2

1. (i) $2x^2 + 1$ (ii) $4a^3 + a^2 - 2a + 4$ (iii) $3b^3 + 2ab^2$
 2. (i) $x^4 - 4x^3 + 1$ (ii) $x - y + 2$ (iii) $-5a^2b - 2b^3$
 3. $3a^4 + 4a^3 - 7a^2 + 7a - 18$ 4. $2x + 2xy - y^2 - 3$
 5. $3x^3 + 3x^2 - 3x - 13$
 6. (i) $x^3 + 27$ (ii) $12x^4 - 34x^3 + 37x^2 - 17x + 5$ (iii) $a^3 + b^3 + c^3 - 3abc$
 7. $PQ = x^2y^2 - x^3z - y^3z + xyz^2$, $QR = y^2z^2 - xy^3 - xz^3 + x^2yz$
 $PR = x^2z^2 - x^3y - yz^3 + xy^2z$, $PQR = xyz(x^3 + y^3 + z^3) - (x^3y^3 + y^3z^3 + z^3x^3)$
 8. (i) $x + 3$ (ii) $x^2 - 3x - 10$ (iii) $x^4 + x^3y + x^2y^2 + xy^3 + y^4$
 (iv) $x^2 - x - 12$ (v) $4a^3 + 2a^2 + a - 1$ (vi) $x^2 - xy - y^2$
 9. 3 10. $2y - 1$ 11. $P = 9$

REVIEW EXERCISE 5

1. (i) a (ii) b (iii) b (iv) c (v) b (vi) b (vii) b (viii) b
 (ix) b (x) d
 2. (i) Yes, monomial, 1 (ii) No, not a polynomial (iii) Yes, constant
 (iv) Yes, Biquadratic polynomial
 3. (i) $3a + 5b + 9c$ (ii) $-10x^3 + 4y^2 - 7z$
 4. (i) $-7x^2 + 8y^2 + 3z^2$ (ii) $11x^3 - 2x^2 - 35$ (iii) $-y^4 + 10y^2 - 25$
 (iv) $12a^3 - 21ab + 15a + 8a^2b - 14b^2 + 10b$ (v) $x^3 + x^2 + x + 2$

EXERCISE 6.1

1. (i) 2809 (ii) 5929 (iii) 259081 (iv) 1012036
 2. (i) 3249 (ii) 9025 (iii) 357604 (iv) 3988009

3. (i) 2484 (ii) 39991 (iii) 999999 (iv) 0.9984
 4. (i) 47 (ii) 11 (iii) 7

EXERCISE 6.2

1. $3(x - 3y)$ 2. $x(y + z)$ 3. $2a(3b - 7c)$
 4. $3m^2n(mp - 2)$ 5. $15x(2x^2 - 3y)$ 6. $17(x^2y^2 - 3)$
 7. $x(4x^2 + 3x + 2)$ 8. $2p(p - 2p^2 + 4)$ 9. $xy(x^2 - x + y)$
 10. $7x(x^3 - 2xy + 3y^3)$ 11. $xyz(xyz - z + 1)$ 12. $4xy(x^2y - 2 + y^2)$
 13. $xy^2(y^2 - 3y - 6)$ 14. $xyz(xy + xz + yz)$ 15. $11xy(7x - 3y - 5xy)$
 16. $5x^3(x^2 + 2x + 3)$

EXERCISE 6.3

1. $(x - y)(a + b)$ 2. $(a - 3c)(2b - 1)$ 3. $(x - 3)(x + 2)$
 4. $(x + 5)(x - 2)$ 5. $(x + 2)(x - 7)$ 6. $(x + 3)(x - 4)$
 7. $(y - 9)(y + 3)$ 8. $(x - 8)(x - 4)$ 9. $(x - 5)(x - 7)$
 10. $(x - 13)(x - 2)$ 11. $(x - y)(a - b)$ 12. $(y - a)(y - b)$
 13. $(pq - rs)(a^2 + b^2)$ 14. $(x + y)(ab + cd)$

EXERCISE 6.4

1. $(x + 7)^2$ 2. $(3a + 2b)^2$ 3. $(4 + 3a)^2$ 4. $(5x + 8y)^2$ 5. $7(a + 6)$
 6. $4(a + 15)^2$ 7. $(x - 17)^2$ 8. $(7x - 6)^2$ 9. $(x - 9y)^2$ 10. $(a^2 - 13)^2$
 11. $2(a - 16)^2$ 12. $(1 - 3a^2b^2c)^2$ 13. $x^2(2x - 5yz)^2$ 14. $\left(\frac{3}{4}x + \frac{2}{3}y\right)^2$
 15. $\left(\frac{7}{8}x - \frac{8}{7}y\right)^2$ 16. $\left(\frac{ax}{b} - \frac{cy}{d}\right)^2$ 17. $4x^4(2x - 1)^2$ 18. $(a^2b^2x - c^2d^2y)^2$

EXERCISE 6.5

1. $(3 - x)(3 + x)$ 2. $6(y - 1)(y + 1)$
 3. $(4xy - 5ab)(4xy + 5ab)$ 4. $xy(x - y)(x + y)$
 5. $16(a - 5b)(a + 5b)$ 6. $a^2b(b - 8)(b + 8)$
 7. $7x(y - 7)(y + 7)$ 8. $5x(x - 3)(x + 3)$
 9. $11(a + b - 3c)(a + b + 3c)$ 10. $3(5 - a + b)(5 + a - b)$
 11. $\left(x - \frac{9}{5} + \frac{6}{5}y\right)\left(x - \frac{9}{5} - \frac{6}{5}y\right)$ 12. $\left(9x + \frac{53}{4}\right)\left(x - \frac{3}{4}\right)$
 13. $(11a - 3b)(11b - 3a)$ 14. $\left(14x - \frac{23}{2}\right)\left(-2x + \frac{17}{2}\right)$
 15. 121000 16. 348340 17. 1 18. 0.800

EXERCISE 6.6

1. $(a + b - c)(a + b + c)$ 2. $(a + 3b + 4c)(a + 3b - 4c)$ 3. $(a + b + 3ab)(a + b - 3ab)$
 4. $(x - 2y - 3xy)(x - 2y + 3xy)$ 5. $(3a - b - 4c)(3a - b + 4c)$

EXERCISE 6.7

1. (i) $x^3 + 12x^2 + 48x + 64$ (ii) $8m^3 + 12m^2 + 6m + 1$
 (iii) $a^3 - 6a^2b + 12ab^2 - 8b^3$ (iv) $125x^3 - 75x^2 + 15x - 1$

- (v) $8a^3 + 12a^2b + 6ab^2 + b^3$ (vi) $27x^3 + 270x^2 + 900x + 1000$
 (vii) $8m^3 + 36m^2n + 54mn^2 + 27n^3$ (viii) $64 - 144a + 108a^2 - 27a^3$
 (ix) $27x^3 + 81x^2y + 81xy^2 + 27y^3$ (x) $343 + 294b + 84b^2 + 8b^3$
 (xi) $64x^3 - 96x^2y + 48xy^2 - 8y^3$ (xii) $125m^3 + 300m^2n + 240mn^2 + 64n^3$
 2. 488 3. 36 4. 322 5. 14 6. (i) 2197 (ii) 1092727 (iii) 0.970299

EXERCISE 6.8

1. (i) $x - y = 26$ (ii) $6x = y$ (iii) $x + 3y = 25$
 (iv) $\frac{x+y}{x-y} = 1$ (v) $2x + 7 = y$
 2. $(1, 1), \left(\frac{1}{2}, 2\right)$ 3. $(0, 2), (1, 1), (2, 0)$ 4. $(0, 0), (1, 2), (2, 4), (3, 6)$
 5. Yes 6. $(0, 3)$

EXERCISE 6.9

1. (i) $\{(2, -1)\}$ (ii) $\{(1, 1)\}$ (iii) $\left\{\left(0, 1\right)\right\}$
 (iv) $\{(4, 0)\}$ (v) $\left\{\left(\frac{30}{19}, -\frac{18}{19}\right)\right\}$ (vi) $\{(5, 2)\}$
 2. (i) $\left\{\left(\frac{8}{3}, -\frac{1}{6}\right)\right\}$ (ii) $\left\{\left(\frac{7}{9}, \frac{50}{9}\right)\right\}$ (iii) $\left\{\left(\frac{23}{25}, -\frac{88}{25}\right)\right\}$
 (iv) $\left\{\left(\frac{11}{19}, \frac{24}{19}\right)\right\}$ (v) $\left\{\left(\frac{5}{3}, \frac{10}{3}\right)\right\}$ (vi) $\left\{\left(\frac{3}{5}, \frac{9}{5}\right)\right\}$
 3. (i) $\left\{\left(\frac{-8}{3}, \frac{-7}{3}\right)\right\}$ (ii) $\left\{\left(\frac{-441}{23}, \frac{433}{23}\right)\right\}$ (iii) $\left\{\left(\frac{140}{17}, \frac{50}{17}\right)\right\}$
 (iv) $\{(11, 1)\}$ (v) $\{(-2, -3)\}$ (vi) $\left\{\left(\frac{-68}{9}, \frac{47}{9}\right)\right\}$

EXERCISE 6.10

1. 2 2. -16 3. 3, 2 4. 11, 7
 5. Adnan's age = 14 years, Adeel's age = 7 years
 6. Ahsan's age = 61 years, Shakeel's age = 13 years 7. $\frac{3}{8}$
 8. Price of melons = Rs. 50 per kg, Price of mangoes = Rs. 80 per kg
 9.. Football = Rs. 250, Basketball = Rs. 180 10. $\frac{3}{5}$ 11. $\frac{4}{7}$

EXERCISE 6.11

1. (i) $bc = ad$ (ii) $y = \frac{1}{5}$ (iii) $2a(a - b) = 0$
 (iv) $a^2 + b^2 + 6ab = 0$ (v) $\ell^2 - m^2 + a = 0$
 2. (i) $2S = t(2v_f - at)$ (ii) $2aS = at(-at + 2v_f)$ (iii) $2S = 2v_f t + 3gt^2$

EXERCISE 6.12

1. (i) $m^2 - n^2 = -2$ (ii) $a^2 - 4b^2 = -8$ (iii) $a^2 - b^2 = -2$ (iv) $4a^2 - 9b^2 = 4$
 (v) $m^3 - \ell^3 = 3\ell$ (vi) $p^2 - 2q^2 = -2$ (vii) $9m^4 - n^4 = 2$ (viii) $2(2a^2 + 1) = 0$
2. (i) $b^2x^3 = a^3y^2$ (ii) $x^2 + y^2 = -6xy$

REVIEW EXERCISE 6

1. (i) a (ii) d (iii) c (iv) b (v) b (vi) b (vii) a
 (viii) c 3. 2207
4. (i) $3x(y + 2xy^2 + 3z)$ (ii) $(y^2 - 6)^2$ (iii) $(x^4 + y^4)(x^2 + y^2)(x + y)(x - y)$
5. (i) 2197 (ii) $8x^3 - 36x^2y + 54xy^2 - 27y^3$ (iii) $343a^3 - 147a^2b + 21ab^2 - b^3$
6. 110 7. (i) $b^2c + mab = 0$ (ii) $n^2s + \ell nt + \ell^2u = 0$
8. (i) $a^2 - 9b^2 - 18 = 0$ (ii) $a^3 + 9b = 27b^3$ (iii) $a^4 + 2 + 4a^2 = b^4$ 9. $\frac{5}{7}$
10. (i) $x^2 - \frac{y^2}{a^2} = 1$ (ii) $\frac{1}{a^2x^2} + \frac{y^2}{b^2} = 1$

EXERCISE 7.1

1. 90° 2. 60° 3. 54° 4. $m\angle 4 = m\angle 5 = m\angle 8 = 105^\circ$
5. (i) $7^\circ, 75^\circ$ (ii) $-7^\circ, 132^\circ$ (iii) $35^\circ, 110^\circ$ (iv) $45^\circ, 60^\circ$

EXERCISE 7.2

1. (i) $e = 63^\circ, f = 78^\circ$ (ii) $x = 110^\circ, y = 70^\circ$ (iii) $g = 16\text{cm}, h = 14\text{cm}$
 (iv) $x = 95^\circ, y = 95^\circ$ (v) $x = 20^\circ$

EXERCISE 7.3

1. (i) $x = 30^\circ, y = 110^\circ, z = 30^\circ$ (ii) $x = 70^\circ, y = 65^\circ, z = 45^\circ$
 (iii) $x = 50^\circ, y = 40^\circ, z = 40^\circ$
2. $76^\circ, 104^\circ$ 3. $36^\circ, 144^\circ$ 4. $85^\circ, 95^\circ$ 5. 156°

REVIEW EXERCISE 7

1. (i) (ii) a (iii) d (iv) a (v) a (vi) a (vii) c
 (viii) d (ix) a (x) b (xi) c (xii) d (xiii) d
2. (a) (i) 1, 9 ; 2, 10 ; 3, 11 ; 4, 12
 5, 13 ; 6, 14 ; 7, 15 ; 8, 16
 (ii) 6, 9 ; 8, 11 ; 5, 10 ; 7, 12
 (iii) 1, 6 ; 2, 5 ; 3, 8 ; 4, 7
 9, 14 ; 10, 13 ; 11, 16 ; 12, 15
 (iv) 5, 9 ; 6, 10 ; 7, 11 ; 8, 12
- (b) $m\angle 2 = 25^\circ, m\angle 3 = 25^\circ, m\angle 8 = 155^\circ, m\angle 14 = 155^\circ, m\angle 16 = 155^\circ$
3. (i) 124° (ii) 52° (iii) 23°

REVIEW EXERCISE 8

1. (i) b (ii) a (iii) b (iv) a (v) a (vi) b (vii) b (viii) a

EXERCISE 9.1

1. (i) 13cm (ii) $2\sqrt{7}\text{cm}$ (iii) 12cm (iv) 25cm (v) 8cm (vi) 10cm
 2. 7cm 3. 8m 4. 7.5cm 6. 10.12m 7. (i) is not right angled triangle
 8. (i) 11cm (ii) 1cm (iii) 1m (iv) $6\sqrt{5}\text{m}$
 (v) $10\sqrt{2}\text{dm}$ (vi) $5\sqrt{5}\text{dm}$ 9. $\sqrt{a^2 - 25}$

EXERCISE 9.2

1. 2754m^2 2. (i) 84cm^2 (ii) 30cm^2 (iii) 272.02cm^2
 3. (i) $6\text{m}, 14.70\text{m}^2$ (ii) $6\text{m}, 24\text{m}^2$ (iii) $7\text{m}, 8.79\text{m}^2$ (iv) $5.25\text{m}, 4.353\text{m}^2$
 4. (i) 261.90cm^2 (ii) 232.93cm^2 (iii) 4.68cm^2 (iv) 2.00cm^2
 5. (a) (i) 24cm^2 (ii) 24cm^2 (b) 48cm^2

EXERCISE 9.3

1. (i) 154cm^2 (ii) 98.56m^2 (iii) 0.55m^2
 2. (i) 3.5m (ii) 4.29m (iii) 4.95m
 3. (i) 817.6cm^3 (ii) 2759.44cm^3 (iii) 1437.33cm^3
 (iv) 164.70m^3
 4. (i) $4\text{cm}, 268.19\text{cm}^3$ (ii) $0.44\text{cm}, 0.36\text{cm}^3$ (iii) $7\text{m}, 1437.33\text{m}^3$
 5. 1913090.67ℓ 6. (i) 4:1 (ii) 8:1
 7. $V = 2304\pi\text{cm}^3, 13824$ (approx.) 8. 900cm

EXERCISE 9.4

1. (i) 6, 188.57, 113.14, 301.71 (ii) 5, 47.14, 28.28, 75.42
 (iii) 23.32, 707.14, 254.57, 961.71 (iv) 7, 7.14, 10, 220
 2. (i) 37.7cm^3 (ii) 513.33cm^3 (iii) 125.7cm^3 (iv) 201.35cm^3
 3. 83.79cm^3 (approx.) 4. 75.43cm^3 (approx.) 5. 134.75cm^3 6. 44

REVIEW EXERCISE 9

1. (i) b (ii) a (iii) c (iv) c (v) a (vi) c
 3. (i) 137.31cm^3 (approx.) (ii) 37.71cm^3 (approx.) (iii) 8.18cm^2 (approx.)

EXERCISE 10.1

1. (i) 134° (ii) 76° (iii) $45^\circ, 135^\circ$ (iv) 30° (v) 165° (vi) 135°

EXERCISE 10.2

1. $m\overline{PQ} = m\overline{ST}, m\overline{QR} = m\overline{TU}, m\overline{RQ} = m\overline{US}$
 $m\angle P = m\angle S, m\angle Q = m\angle T, m\angle R = m\angle U$
 2. (a) SAS (b) SSA (c) SAS (d) SSA 5. 90°

REVIEW EXERCISE 10

1. (i) d (ii) a (iii) a (iv) d (v) a (vi) a (vii) d
 (viii) a (ix) b (x) c
2. (i) $x = 20^\circ, 105^\circ, 75^\circ$ (ii) 93°
 (iii) $a = 114^\circ, b = 66^\circ$ (iv) $x = 31^\circ, 42^\circ, 107^\circ$

EXERCISE 11.1

- 1.(a) (i) $\frac{4}{5}$ (ii) $\frac{3}{5}$ (iii) $\frac{4}{3}$ (iv) $\frac{5}{3}$ (v) $\frac{5}{4}$
 (vi) $\frac{4}{3}$ (vii) $\frac{3}{4}$ (viii) $\frac{3}{5}$ (ix) $\frac{5}{4}$ (x) $\frac{4}{5}$
- (b) (i) $\frac{8}{17}$ (ii) $\frac{15}{17}$ (iii) $\frac{8}{15}$ (iv) $\frac{17}{15}$ (v) $\frac{17}{8}$
 (vi) $\frac{8}{15}$ (vii) $\frac{15}{8}$ (viii) $\frac{15}{17}$ (ix) $\frac{17}{8}$ (x) $\frac{8}{17}$
2. (i) $\frac{m\overline{BC}}{m\overline{AC}}$ (ii) $\frac{m\overline{AB}}{m\overline{AC}}$ (iii) $\frac{m\overline{BC}}{m\overline{AB}}$ (iv) $\frac{m\overline{AB}}{m\overline{AC}}$
 (v) $\frac{m\overline{BC}}{m\overline{AC}}$ (vi) $\frac{m\overline{AB}}{m\overline{BC}}$
3. (i) $\frac{\sqrt{b^2 - c^2}}{c}$ (ii) $\frac{\sqrt{b^2 - c^2}}{b}$ (iii) $\frac{c}{\sqrt{b^2 - c^2}}$ (iv) $\frac{b}{\sqrt{b^2 - c^2}}$
 (v) $\frac{b}{c}$ (vi) $\frac{\sqrt{b^2 - c^2}}{c}$ (vii) $\frac{\sqrt{b^2 - c^2}}{b}$ (viii) $\frac{c}{b}$
 (ix) $\frac{\sqrt{b^2 - c^2}}{c}$ (x) $\frac{b}{c}$ (xi) $\frac{b}{\sqrt{b^2 - c^2}}$ (xii) $\frac{c}{\sqrt{b^2 - c^2}}$
4. (i) $\frac{\sqrt{3}}{2}$ (ii) $\frac{4}{\sqrt{2}}$ (iii) 0 (iv) $\frac{\sqrt{3}}{2}$

REVIEW EXERCISE 11

1. (i) b (ii) b (iii) a (iv) b (v) c (vi) b
 (vii) b (viii) c (ix) a (x) a (xi) b
2. (i) $\frac{3}{\sqrt{2}}$ (ii) $\frac{\sqrt{3}}{2}$ (iii) $\frac{4}{\sqrt{2}}$ (iv) 1
3. (i) $\frac{2}{\sqrt{2}}$ (ii) $\frac{7}{\sqrt{2}}$ (iii) $\frac{2}{\sqrt{2}}$

EXERCISE 12.2

1. (i) Mean = 5.4, Median = 5.5, Mode = 8
 - (ii) Mean = 4.64, Median = 5, Mode = 5
 - (iii) Mean = 17.5, Median = 4, Mode = 4
 - (iv) Mean = 76.2, Median = 75, Mode = Nil
 - (v) Mean = 72.9, Median = 76.5, Mode = 80
 - (vi) Mean = 3.15, Median = 3, Mode = 3
 - (vii) Mean = 105, Median = 106, Mode = 106, 107, 108
 - (viii) Mean = 7.27, Median = 7, Mode = 7, 8
 - (ix) Mean = 174, Median = 146.5, Mode = Nil
 - (x) Mean = 4344, Median = 3937.5, Mode = 2500
2. *Rs. 120.74*
 3. Mean = 11.8, Median = 10, Mode = 1, 5, 10
 4. Mean = 3.2, Median = 3, Mode = 2
 5. Class marks: 19.5, 59.5, 99.5, 139.5, 179.5, Mean = 104.81
 6. Mean = 19.53 7. (a) Mode = 2 (b) Mean = 2.15 (c) Median = 2

REVIEW EXERCISE 12

1. (i) b (ii) c (iii) a (iv) b (v) a (vi) a
 (vii) c (viii) b (ix) c

	Mean	Median	Mode
a.	5	4	3
b.	11	11	12
c.	5.5	5	5
d.	7	7.5	8
e.	154.3	154.7	152.3

4. Mean = Rs.76.68 , Median = Rs.76.65 , Mode = Rs.76.7

Glossary

Algebraic Expression: is a mathematical phrase that can contain ordinary numbers, variables (like x , y etc.) and operations (like addition, subtraction, multiplication and division), called linear polynomials.

Arithmetic Mean: The sum of all values divided by the number of values is known as Arithmetic Mean.

ATM: An automated teller machine (ATM) is an electronic device that allows a bank's customers to draw cash and check their account balance.

Axiom: is a self-evident truth which needs no proof or demonstration and can be taken for granted.

Banking: is a business activity of accepting and safeguarding the money and earning a profit by lending out this money.

Base 5 Number System: In base 5 number system, five digits 0, 1, 2, 3 and 4 are used to represent numbers in the system.

Binary Number System: The number system with base 2 is also called "Binary number system".

Central Tendency: is defined as "the statistical measure that identifies a single value as representative of an entire distribution".

Chord: is a line segment whose endpoints lie on the circle.

Circle: is a simple plane shape of geometry with all its points at the same distance (called the radius) from a fixed point (called the centre of the circle).

Commercial Banking: The function of a bank which accepts deposits, provide loans and services to the clients is known as commercial banking.

Compound Proportion: The relationship between two or more proportions is known as compound proportion.

Concentric Circles: Two or more circles with common centre and different radii are called concentric circles.

Concyclic: A set of points is said to be concyclic (or cocyclic) if they lie on a common circle.

Construction: In this part of the proposition, we note down all the additional lines or figures which must be drawn so that we may be able to arrive at the required result.

Converging Lines: are non-parallel lines meet at a single point.

Corollary: is also a proposition, the truth of which can be immediately drawn from the theorem that has already been proved.

Credit Card: is a thin plastic card used to by articles. Visa and Master cards are used worldwide for making payments. These are the names of global credit companies.

Cube: of a number means to multiply the number by itself three times.

Debit Card: is a plastic payment card that provides card holder electronic access to his bank account at anytime and anywhere.

Decimal Number System: is a place value system in which value of each position is some power of 10 starting from zero onwards.

Demand Draft: is a method used by individuals to make transfer payments from one bank account to another.

Demonstrative Geometry: is used to demonstrate the truth of mathematical statements concerning geometric figures.

Factorization: Polynomials as product of two or more polynomials that cannot be further expressed as product of factors is called Factorization.

Foreign Currency Account: is the account maintained by the currency other than Pakistani currency.

Frequency Distribution Table: is one way we can organize data so that it makes more sense. We could draw a frequency distribution table, which will give a better picture of our data than a simple list.

Frequency Distribution: is a summary of how often different scores occur within a sample of scores.

Frequency: is a number which indicates how often a value occurs.

Geometrical Theorem: is that kind of proposition in which we establish a geometrical truth by means of reasoning with the help of a geometrical figure.

Given: For the sake of convenience and clarity, we first of all put down what is given to us or what is assumed.

Histogram: is a representation of a frequency distribution by means of rectangles whose widths represent class intervals and whose areas are proportional to the corresponding frequencies.

Improper Subset: If A is a subset of B and A is equal to B (i.e. every element of B is also the element of A), then A is an improper subset of B , denoted by $A \subseteq B$.

Income tax: is imposed on the annual income of a person whose income exceeds a certain limit which is determined by the government.

Inheritance: When a person dies, then the assets left by him is called inheritance.

Insurance: is a system of protecting or safeguarding against risk or injuries.

Intersection: of two sets $A \cap B$, is a set which consists of only the common elements of both A and B .

Irrational Number: The number which cannot be written in the form of $\frac{p}{q}$ where $p, q \in Z$ and $q \neq 0$ is called irrational number.

Lease: is contractual agreement between the lessee (user) to pay the lessor (owner) for the use of an asset.

Linear Equation: If a, b and r are real numbers (and if a and b are not both equal to 0) then $ax + by = r$ is called a linear equation in two variables x and y , a and b are coefficients and r is constant of the equation.

Literal: The alphabets that are used to represent constants or coefficients are called literals.

Mark-up: Extra money which a bank receives from a client on borrowed money is known as mark-up.

Median: is the value which occupies the middle position when all the observations are arranged in an ascending /descending order.

Mode: is defined as the value that occurs most frequently in the data. Some data do not have a mode because each value occurs only once.

Non-terminating Decimal Fraction: The decimal fraction, in which the digits after the decimal point are infinite, is called non-terminating.

Octal Number System: The number system with base 8 is also called "Octal number system". In octal number system eight digits 0, 1, 2, 3, 4, 5, 6 and 7 are used to represent numbers in the system.

Online Banking: is the use of internet by the banks to assist their customers.

Overdraft: is a borrowing facility provided by a bank to account holder to withdraw some amount excess of his original balance.

Parallel lines: Two lines on a plane that do not intersect at any point are called parallel lines. Parallel lines are always the same distance apart.

Parallelogram: is a special type of quadrilateral whose pairs of opposite sides are parallel.

Partnership: A business in which two or more persons run the business and are responsible for profit or loss is called partnership.

Pay Order: is a document which instructs a bank to pay a certain amount to a third party and it is issued by the bank on the request of its customer.

Polygon: is a closed plane figure with three or more straight sides.

Polynomial: An algebraic expression which has finite number of terms and the exponents of variables are whole numbers, is called polynomial.

Postulate: is that elementary statement which we have to assume while making a demonstration.

Principal Amount: is the amount we borrow or deposit in the bank.

Proper Subset : If A is a subset of B and A is not equal to B (i.e. there exists at least one element of B not contained in A), then A is a proper subset of B , denoted by $A \subset B$.

Proposition: is a declarative sentence that is either true or false. There are three parts to any proposition.

Pythagoras Theorem: In right angled triangle, the square of the hypotenuse is equal to the sum of the squares of the other two sides.

Quadrilateral: is a 4-sided polygon.

Real Number: Set of Real Numbers is the union of Rational and Irrational Numbers i.e. $R = Q \cup Q'$

Regular Hexagon: In a regular hexagon, all the six sides are equal in length and the sum of its six interior angles is 720° .

Regular Pentagon: In a regular pentagon, all the five sides are equal in length and the sum of its five interior angles is 540° .

Secant: is an extended chord, a straight line cutting the circle at two points.

Sector: is a region bounded by two radii and an arc lying between these two radii.

Set: is defined as "a collection of well defined distinct objects". These objects are called elements or members of a set.

Simultaneous Linear Equations: mean a collection of linear equations all of which are satisfied by the same values of the variables.

Subset: A set A is a subset of a set B if every element in set A is also an element in set B .

Tangent: is a straight line that touches the circle at a single point externally.

Terminating Decimal Fraction: The decimal fraction in which the digits after the decimal point are finite, is called terminating decimal fraction.

To Prove: In this, we put down what we are going to prove or establish.

Trigonometric Ratios: The three most common ratios in trigonometry are sine, cosine and tangent. Trigonometric ratios are simply one side of a triangle divided by another.

Trigonometry: is derived from three words: Trei (three), Goni (angles) and Metron (measurement).

Union: of two sets $A \cup B$, is a set which consists of elements of both A and B with common elements represented only once.

Venn Diagram: is a pictorial representation of sets and operations performed on sets.

Symbols

Symbol	Stands for	Symbol	Stands for
$<$	is less than	$:$	ratio
$>$	is greater than	$::$	is proportional to
\leq	is less than or equal to	$ $	tally mark
\geq	is greater than or equal to	Σ	summation
$=$	is equal to	\overline{AB}	line segment AB
\neq	is not equal to	\overrightarrow{AB}	ray AB
\nless	is not less than	\overleftrightarrow{AB}	line
\ngtr	is not greater than	\angle	angle
\in	belongs to	Δ	triangle
\notin	not belongs to	\sim	is similar to
\forall	for all	\cong	is congruent to
$\sqrt{\quad}$	square root	\approx	is approximately equal to
\Rightarrow	implies that	\parallel	is parallel to
\cup	union	\widehat{AB}	arc AB
\cap	intersection	\leftrightarrow	correspondence
\because	because / as	$\%$	percentage
\therefore	therefore / so	\emptyset or $\{\}$	the empty set / the null set
U	universal set	$ $	such that